

NTAGE



QUALITY



ROLLERGRILLES & ROLLERSHUTTERS

www.knightguard.co.nz



KNIGHTGUARD

For over 25 years Knightguard Rollergrilles and Rollershutters have been the preferred choice of thousands of commercial and residential end users throughout New Zealand & the Pacific.

Quality and dependability are combined with innovative design, to produce a wide range of versatile roller security solutions.

Every installation is different, therefore each Rollergrille or Rollershutter is custom made and then expertly installed by one of our authorised Knightguard dealers.



KNIGHTGUARD

APPLICATIONS

- Shop Fronts
- Arcades
- Bar Tops
- Cafeterias
- Shop Windows

OPERATION

- Spring Balanced or Motorised

FINISH

- Satin Silver Anodised Aluminium or Oasis Satin Black

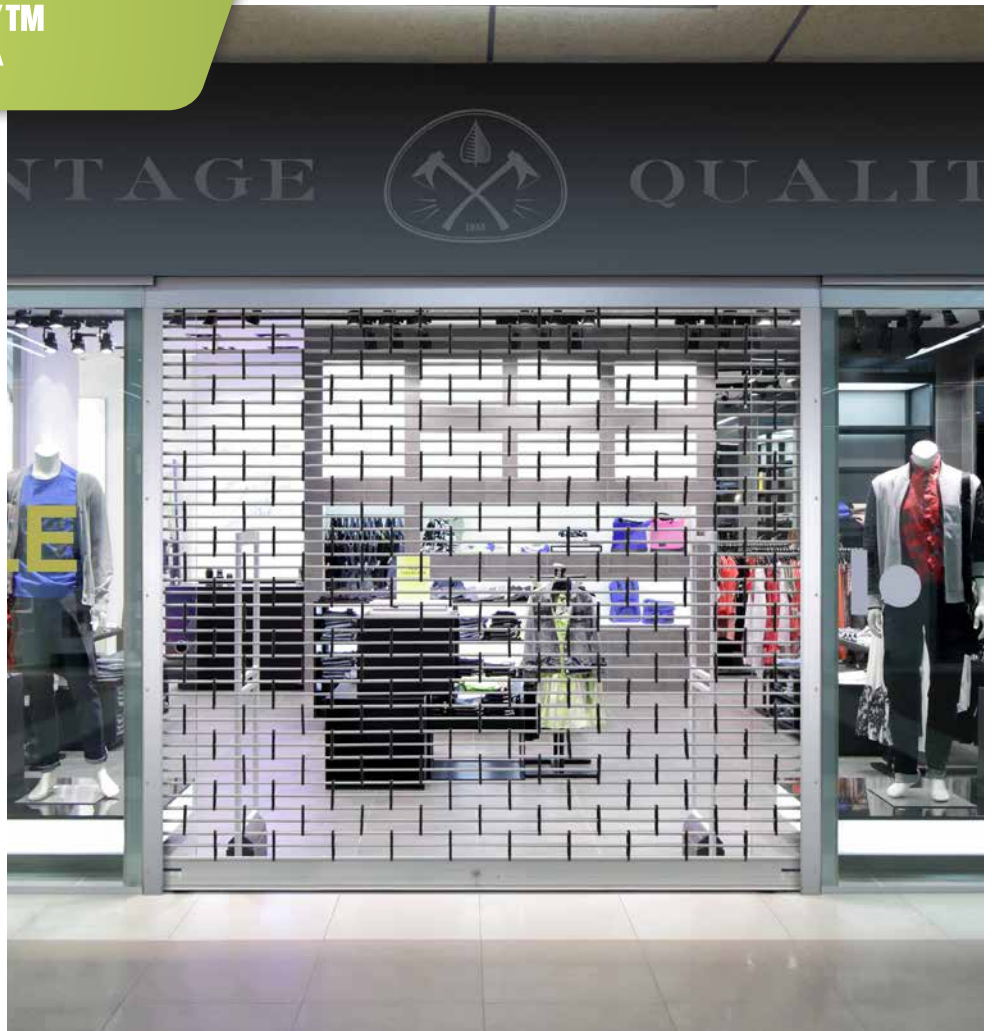

ECONOMIC ROLLERGRILLES

Econolink Rollergrilles provide high quality security with visibility and airflow, all at an economic price.

MAX HEIGHT
3250mm

MAX WIDTH
5000mm

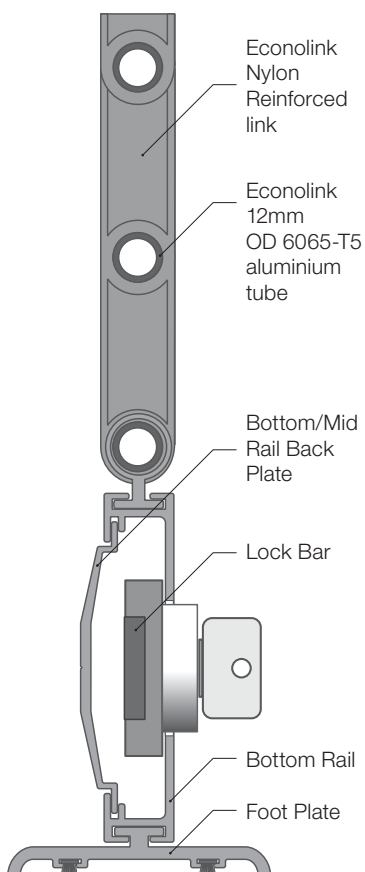

HEIGHT	1000	1500	2000	2500	3000	3250
ROLL DIAMETERS	240	290	320	335	350	360

CONSTRUCTION: Heavy Duty 12mm OD 6065-T5 aluminium tubes with nylon links (reinforced with fibreglass), for superior strength.

ASSEMBLY: Tubes - 45 mm apart, centre to centre.
Links - 3 tubes per link.
Assembled in brick pattern at 200mm intervals.

GUIDES: 76mm x 32mm full height side guide, with double mohair channels.

LOCKING: Double throw pin cylinder key system at the bottom, or mid rail position (non motorised operation).

AXLE: 70mm galvanised steel octagonal central axle, with 130mm nylon adapter wheels.

*Doorways over 5000mm wide can be accommodated with adjoining doors, where the side guides are joined back to back, creating a removable mullion. Larger configurations only available in motorised operation.

SHUTTERGRILLE™

APPLICATIONS

- Shop Fronts
- Arcades
- Bar Tops
- Cafeterias
- Shop Windows

OPERATION

- Spring Balanced or Motorised

FINISH

- Satin Silver Anodised Aluminium or Dulux® Powder Coat colours

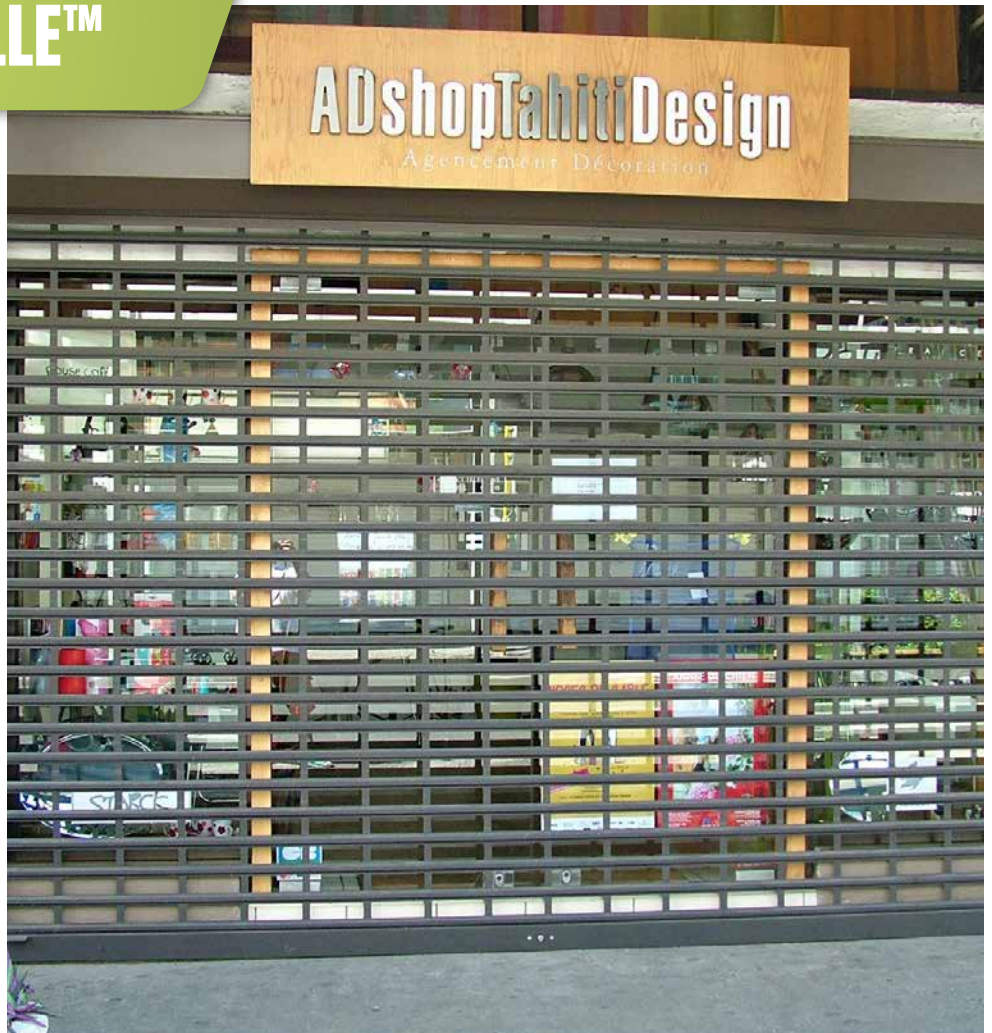
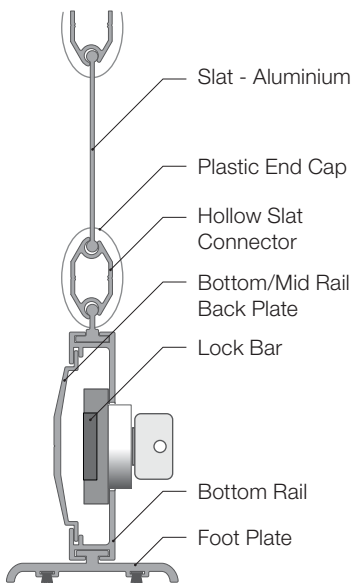

PUNCHED & SOLID ROLLERGRILLES

Shuttergrille Rollergrilles use punched/and or unpunched slats to form a continuous shutter.

MAX HEIGHT
3250mm

MAX WIDTH
5000mm

OPTIONS

- Rectangular Punched, Twin-Row Diamond Punched, Elliptical Punched, Plain Unpunched, Combination - Punched and Unpunched



Twin Row
Diamond Punched
Vertically Aligned



Twin Row
Diamond Punched
in Brick Pattern



Rectangular/
Square Punched



Rectangular/
Square Punched in
Brick Pattern

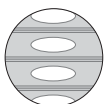

Elliptical Punched,
Vertically Aligned

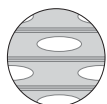

Elliptical Punched
in Brick Pattern

HEIGHT	1000	1500	2000	2500	3000	3250
ROLL DIAMETERS	185	225	250	270	285	300

CONSTRUCTION: Extruded aluminium slats connected to form a continuous Rollergrille.

ASSEMBLY: Aluminium slats – punched, unpunched or combination of both. 3 punched designs formed into brick or vertically aligned pattern. Connected with 30.4mm extruded aluminium slat connector.

GUIDES: 76mm x 32mm full height side guide, with double mohair channels.

LOCKING: Double throw pin cylinder key system in bottom or mid rail position (non motorised operation).

AXLE: 70mm galvanised steel octagonal central axle, with 130mm nylon adapter wheels.

*Doorways over 5000mm wide can be accommodated with adjoining doors, where the side guides are joined back to back, creating a removable mullion. Larger configurations only available in motorised operation.

APPLICATIONS

- Shop Fronts
- Shopping malls
- Bar Tops
- Cafeterias
- Doors and Windows

OPERATION

- Spring Balanced or Motorised

FINISH

- Satin Silver Anodised Aluminium or Dulux® Powder Coat colours, with Clear Polycarbonate Slat



SEALED & SEE-THROUGH ROLLERGRILLES

Visionline Rollergrilles restrict access but not visibility, with strong & secure transparent slats.

MAX HEIGHT
3250mm

MAX WIDTH
5000mm

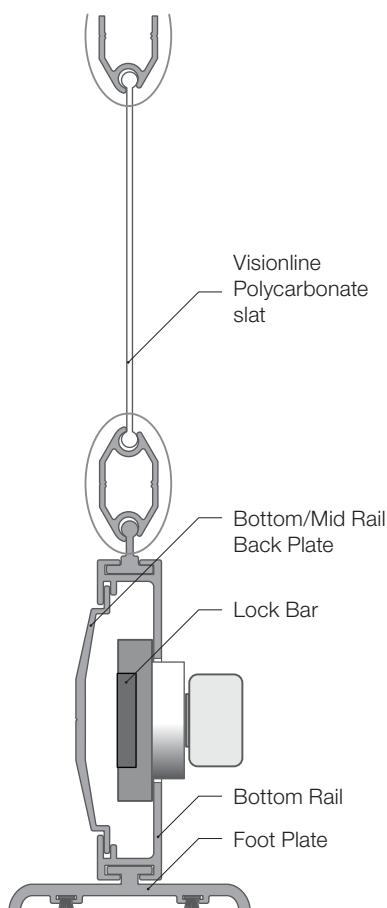

HEIGHT	1000	1500	2000	2500	3000	3250
ROLL DIAMETERS	200	240	270	295	325	340

CONSTRUCTION: Strong polycarbonate slats interlocked with aluminium connector rails.

ASSEMBLY: As above.

GUIDES: 76mm x 32mm full height side guide, with double mohair channels.

LOCKING: Double throw pin cylinder key system at the bottom, or mid rail position (non motorised operation).

AXLE: 70mm galvanised steel octagonal central axle, with 130mm nylon adapter wheels.

*Doorways over 5000mm wide can be accommodated with adjoining doors, where the side guides are joined back to back, creating a removable mullion. Larger configurations only available in motorised operation.

ULTRA SECURITY™

APPLICATIONS

- Large Shop Fronts
- Car Parks
- Supermarket Entrances

OPERATION

- Spring Balanced or Motorised (Low Cycle) Operations

FINISH

- Satin Silver Anodised Aluminium



HEAVY DUTY ROLLERGRILLES

Ultra Security Rollergrilles offer the ultimate in tough security grilles.

MAX HEIGHT
3250mm

MAX WIDTH
5500mm

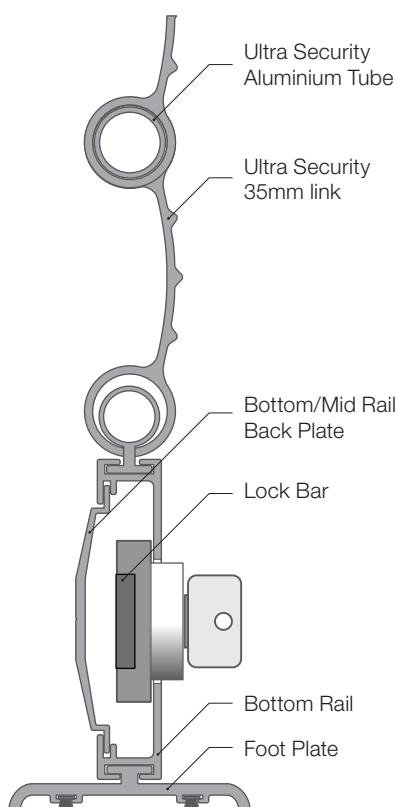

HEIGHT	1000	1500	2000	2500	3000	3250
ROLL DIAMETERS	240	255	270	300	315	325

CONSTRUCTION: Heavy duty 19mm OD 6065-T5 aluminium tubes, connected by high tensile 35mm wide T594 aluminium links.

ASSEMBLY: Tubes - 70 mm apart, centre to centre
Links - 2 tubes per link.
Assembled in brick pattern at 500mm intervals.

GUIDES: 76mm x 32mm full height side guide, with double mohair channels.

LOCKING: Double throw pin cylinder key system at the bottom, or mid rail position (non motorised operation).

AXLE: 70mm galvanised steel octagonal central axle, with 130mm nylon adapter wheels.

*Doorways over 5500mm wide can be accommodated with adjoining doors, where the side guides are joined back to back, creating a removable mullion. Larger configurations only available in motorised operation.

APPLICATIONS

- Residential
- Bar Tops
- Kitchens
- Cafeterias
- Serverys
- Boat Hatches
- Cabinets

OPERATION

- Spring Balanced or Motorised

FINISH

- Satin Silver Anodised Aluminium or Dulux® Powder Coat Colours

OPTIONS

- 40mm Single Wall
40mm Double Wall
(Vented or Unvented)
- 25mm Single Wall Curved
40mm Single Wall Diamond
Punched

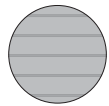

25mm Single Curved Wall

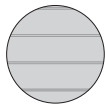

40mm Single or Double Wall

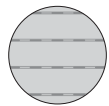

40mm Double Wall, Vented. (Vent holes only seen when curtain partly open. All close off when fully down.)

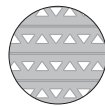

40mm Single Wall - Diamond Punched

COMPACT ROLLERSHUTTERS

Intercept Rollershutters have strong interlocking slats that form a secure rolling curtain/shutter.

MAX HEIGHT
3250mm

MAX WIDTH
4000mm

HEIGHT	1000	1500	2000	2500	3000	3250
HEADBOX - 25mm wall	150	165	180	205	250	300
HEADBOX - 40mm wall	165	180	205	250	300	300

CONSTRUCTION: Interlocking heavy duty aluminium profiles in a choice of four designs.

HEADBOX: Matching folded galvanised headbox in 6 sizes. Removable front cover for easy access and powder coated to match Rollershutter finish.

GUIDES: 58mm x 22mm full height side guide for shutters up to 2 metres wide. 72mm x 22mm full height side guide for shutters over 2 metres wide.

LOCKING: A keyed locking system fitted to the bottom rail (non motorised operation).

AXLE: 60mm or 70mm galvanised steel octagonal central axle, depending on weight of curtain.

80mm adapters available for 60mm Axle.

130mm adapters available for 70mm Axle.

Larger configurations only available in motorised operation.

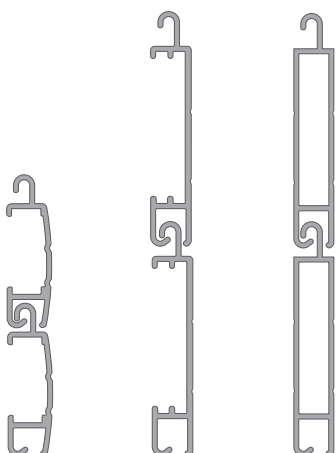

25mm Single Wall Slat

40mm Single Wall Slat

40mm Double Wall Slat

GUIDES

Knightguard Rollergrilles have 76mm deep side guides, to resist forced entry.

Side guides have a flared curtain entrance with double mohair channels, to ensure a smooth quiet operation. Side guides can either be face or reveal fitted. Removable or angle mullions are available for wide or corner openings.

Intercept Rollershutters have 58mm side guides for shutters up to 2m wide and 72mm for those over 2m.

BOTTOM/MID RAIL

Knightguard Rollergrilles have a specially designed 85mm x 17mm bottom/mid rail in extruded Aluminium 6060 alloy, with a T6 temper for greater rigidity and a detachable back plate. A keyed locking system fits within the rail, which can be incorporated at the bottom or middle of the Rollergrille.

Intercept Rollershutters have a 50mm bottom rail as standard. The rails are finished off with a back plate and footplate, both in extruded aluminium 6060-T5. The footplate includes a mohair buffer strip to prevent damage to expensive entrance floor surfaces.

INSTALLATION BRACKET

Knightguard Rollergrilles use 5mm galvanised steel brackets, with several points of adjustment for ease of installation. A steel spring support bracket, with locking Tek screw is incorporated on one end and a 42mm bearing holder bracket on the other.

Intercept Rollershutters use a steel spring support bracket, with locking Tek screw fitted to the left hand headbox end cap. A 42mm bearing and bearing holder is fitted to the right hand headbox end cap.

LOCKING

Both **Knightguard Rollergrilles** and **Intercept Rollershutters** are constructed using a double throw pin cylinder key locking system. This system activates two concealed locking bars located in slots in the side guides. Standard for manual operation and optional for motorised operation.

AXLE

Knightguard Rollergrilles use a 70mm galvanised steel octagonal central axle, with 130mm nylon adapter wheels at 500mm centres.

Intercept Rollershutters use a 60mm or 70mm galvanised steel or aluminium octagonal central axle, depending on Rollershutter weight and adapters.

OPERATION

Standard operation for Rollergrille or Rollershutters is manual, using a helically wound torsion spring inside the central axle. The spring is fitted and pre-tensioned before delivery.

Automation is available with the addition of an optional tubular motor. For larger sized Rollergrilles and Rollershutters, a tubular motor is a requirement due to their weight and size.

FINISH

Knightguard Ultra Security & Econolink - Satin Silver Anodised. Econolink also available in Satin Black.

Knightguard Shuttergrille & Visionline, Intercept Rollershutters - Satin Silver Anodised or 40+ Dulux Powder Coat colours.

QUALITY CONTROL

All finished Knightguard Rollergrille and Intercept Rollershutters are quality checked and tested on Juralco's vertical test rig before dispatch.



To guarantee customer satisfaction and meet a high standard of quality, Knightguard Rollergrilles & Rollershutters are only available from the most highly qualified tradesmen. Authorised Knightguard dealers are licensed to supply genuine Knightguard Products. You can refer to the address here and be confident that you will have a service that matches the Knightguard product quality. The products in this brochure are the subject of intellectual property protection.

All brands are either trademarks of Juralco Aluminium Building Products Ltd or used under licence. Dulux® is a registered trademark of Dulux Group (Australia) PTY LTD.



KNIGHTGUARD

*For warranty terms & conditions see www.knightguard.co.nz

Available from:

Authorised Dealer