



 JURALCO

JURALCO VELASUN®
OUTDOOR LIVING SYSTEM

ISSUE 6-24 v1

Juralco VelaSun® Outdoor Living System

Juralco Aluminium Building Products Ltd designs and distributes specialist aluminium joinery systems through a national network of franchised fabricators and agents.

For more than 25 years we have been at the forefront of specialist aluminium products suitable for New Zealand joinery and building methods. Our comprehensive product range includes security and insect screens, balustrades and gates, shutters and awnings, louvre roofs, shower screens, wardrobe doors and organisers and internal doors.

The VelaSun® Outdoor Living System is an ideal solution for extra outdoor shelter for you home.

The high quality extruded aluminium structure can be custom powder coated in a colour of your choice. There are 3 x types, Roofless (no infill panels) or 2 x Panel infill types Grey Polycarbonate panels to give a diffused light inside the enclosure while blocking out most of the heat. Alternatively Glass panels can be used.

Juralco VelaSun® Outdoor Living System - Principal Features (Panel system Shown)

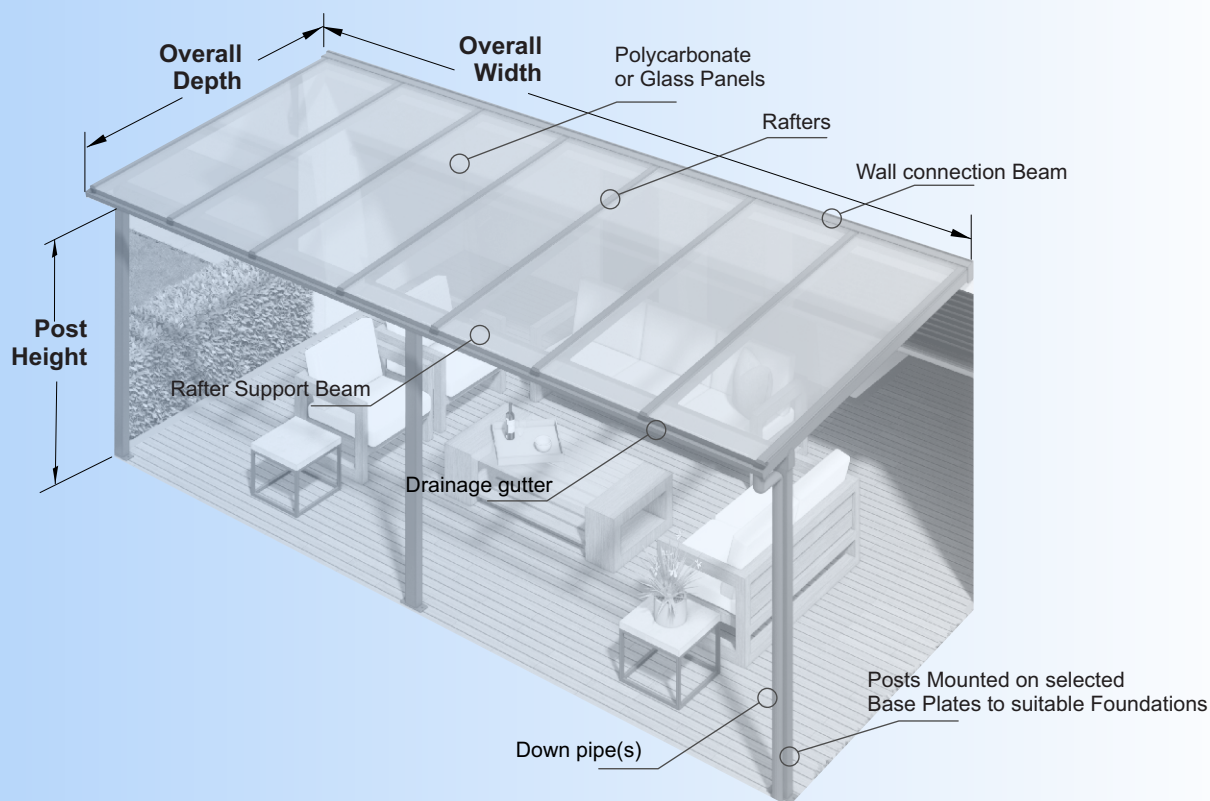

The VelaSun® Outdoor Living System is available in x 3 configurations, all incorporating Rafters and Posts as above.

PERGOLA Type 1 - Completely Open, ie minimal Rain/Sun protection (No Drainage)

or PANEL Types 2 - Panels of Grey Polycarbonate, or 3 - Glass panels.

- Front Drainage Gutter extrusion, connected to Down pipe(s)
- Wall Connection Beam to Rafters
- Rafters, which hold the preformed Polycarbonate or Flat Glass Toughened Panels
- Posts, Single Posts mounted to Base plates, then to suitable Foundations
- Rafter Support Beam. Connects Rafters to Posts
- LED lighting can be inserted into or attached to the Frame.
- Dimensions. Polycarb and Glass. OW -13m max. OD - 4.8m max. Post Height - 2.9m max. Std slope, 5 deg min - 15 deg max
- Dimensions Roofless. OW - 3.6m max. OD - 3.6m max. Post height 2.9m max

Design considerations for the Polycarbonate and Glass Panel Roofs are different:

- The Polycarbonate Panel Roof has been design with a deflection criteria of L/100 at 800mm rafter centres.
- The Glass Panel Roof has been design with a deflection criteria of L/250 at 600mm rafter centres.

The Juralco VelaSun® Outdoor Living System is manufactured by Juralco and supplied as a kitset.

Includes Polycarbonate panels, but not Glass. Any down pipes and fixings supplied by Installer.

Posts Cut to length on site. All assembled on site.

All pre-manufactured in our factory before packing and despatch.

All pages © Copyright Juralco Aluminium Building Products Ltd, 2024

Type	Pages	Description
Specifications	4	General specifications
Configurations	5 - 7	Shows Roofless, Polycarbonate and Glass configurations
Extrusions	8 - 11	Shows all Extrusions and Components
Fixings	12	Shows a Schedule of necessary Fixings
Mountings	13 - 14	Shows Roofless Joints
	15	Shows mounting details to Walls
	16	Shows Polycarbonate and Glass Panel mounting details to Rafters
	17 - 19	Shows mounting details to Soffits and Soffit Brackets details
Connections	20 - 24	Shows General Joints and connections
Base plates	25 - 27	Shows Base Plate mounts to Timber (25), Concrete (26,27)
Technical	28 - 33	Polycarbonate sheet Technical Details. Care and Handling. Fire Report
Poly Carb Panels	34	Shows calculations for no of Panels and OA Width
Order page	35 -37	Order pages. Polycarbonate and Glass (35), Roofless (p36-37)
Powder coat	38	Instructions for the care of Powder coated surfaces



**Juralco VelaSun® Outdoor Living System
Polycarbonate or Glass panel infills**



**Juralco VelaSun® Outdoor Living System
Roofless Type**

Juralco VelaSun® Outdoor Living System - Specifications, Powder Coating

Juralco Aluminium Building Products Ltd (JABP) Specifications for Juralco VelaSun® Outdoor Living System

1. Scope

- This specification details the documents the Juralco VelaSun® Outdoor Living System refers to in relation to the New Zealand Building Code, the manufacturer's documents, products used in the System, requirements in relation to fixing and surface finishings.

2. NZBC Compliance

- The Juralco VelaSun® Outdoor Living System has been reviewed by Lautrec Technology Group Ltd, Engineers. Suitable for NZS3604 Low, Medium, High, Very High and Extra High Wind Zones up to Design Wind pressure of 2.5kPa as noted on the following detail pages, when attached to buildings within the scope of NZS3604

3. Manufacturer's Documents

- The Juralco VelaSun® Outdoor Living System manual details all extrusions and components used for the fabrication and installation/fixing of the system.
- Manuals are available from Juralco Aluminium Building Products Ltd
48 Bruce McLaren Rd, Henderson, Auckland
Phone 09 478 8018 Fax 09 478 7883 Email specify@juralco.co.nz

4. Products

- Only extrusions, components and hardware supplied by or specified by JABP may be used in the Juralco VelaSun® Outdoor Living System
- Aluminium extrusions, components and hardware – unless specified are manufactured to 6060 T5 specifications
- Stainless Steel components, hardware, fixings – all components to 316 grade
- Glass - all glass used in the Juralco VelaSun® Outdoor Living System must be Laminated or Toughened Safety Glass and conform to the specifications as listed in the Juralco VelaSun® Outdoor Living System manual, with each panel conforming to AS/NZS 2208 as confirmed by the Safety Stamp detailing the manufacturer's description and licence number.
- Polycarbonate - Polycarbonate to be VelaGlaze™ 4mm Solid Polycarbonate sheet with 2 x Profiled Edges.
UV protected on both faces,

5. Surface Finishing

- Juralco Aluminium Building Products Ltd is a Dulux Registered Applicator site, registration number 2101. JABP uses only Dulux branded powder coating materials
- Dulux Duralloy® powder coating systems are suitable for properties greater than 100m from high tide level AAMA 2603 performance. Residential buildings, 3 levels max. Warranty 10 yrs
- Dulux Duralloy Plus® powder coating systems are suitable for properties greater than 10m from high tide level. AAMA 2603 performance. Residential and Light commercial buildings, 3 levels max Warranty 15 yrs
- Dulux Duratec® powder coating systems are suitable for properties greater than 10m from high tide level AAMA2603 and 2604 performance. All Residential and Commercial buildings. Warranty 25 yrs

5. Installation and Fixing

- The Juralco VelaSun® Outdoor Living System must only be constructed by our installers in accordance with the Juralco VelaSun® Outdoor Living System manual

Important information - Powder Coating systems.

Powdercoat Systems The new standard Dulux powder coating system used by Juralco is Duralloy Plus®. Also Duralloy® and Duratec®. All as per specs above. Juralco Powder coated prices are for Duralloy Plus® and Duralloy® (same pricing). Duratec® prices on application.

Attachment to structures A PVC Tape or similar material spacer must be used to separate powder coated aluminium items from all concrete and steel structures. Failure to do so can lead to the chemicals in the structure affecting the powder coating, leading to corrosion.

Swimming Pools The chlorinated water in swimming pools can cause the deterioration of powder coated surfaces, leading to corrosion of the underlying surface. It is recommended that Powder coated surfaces be 1200mm min from a pool.

Care The Dulux powder coating warranty period is conditional upon the surface being maintained in accordance with the Dulux 'Care and Maintenance Instructions'. Download from Dulux or refer to the back page of this manual.



Juralco VelaSun® Outdoor Living System - Roofless Pergola. Typical Configurations

Basic Roofless Pergola Configuration

Note - ROOFLESS Types are installed Horizontal,

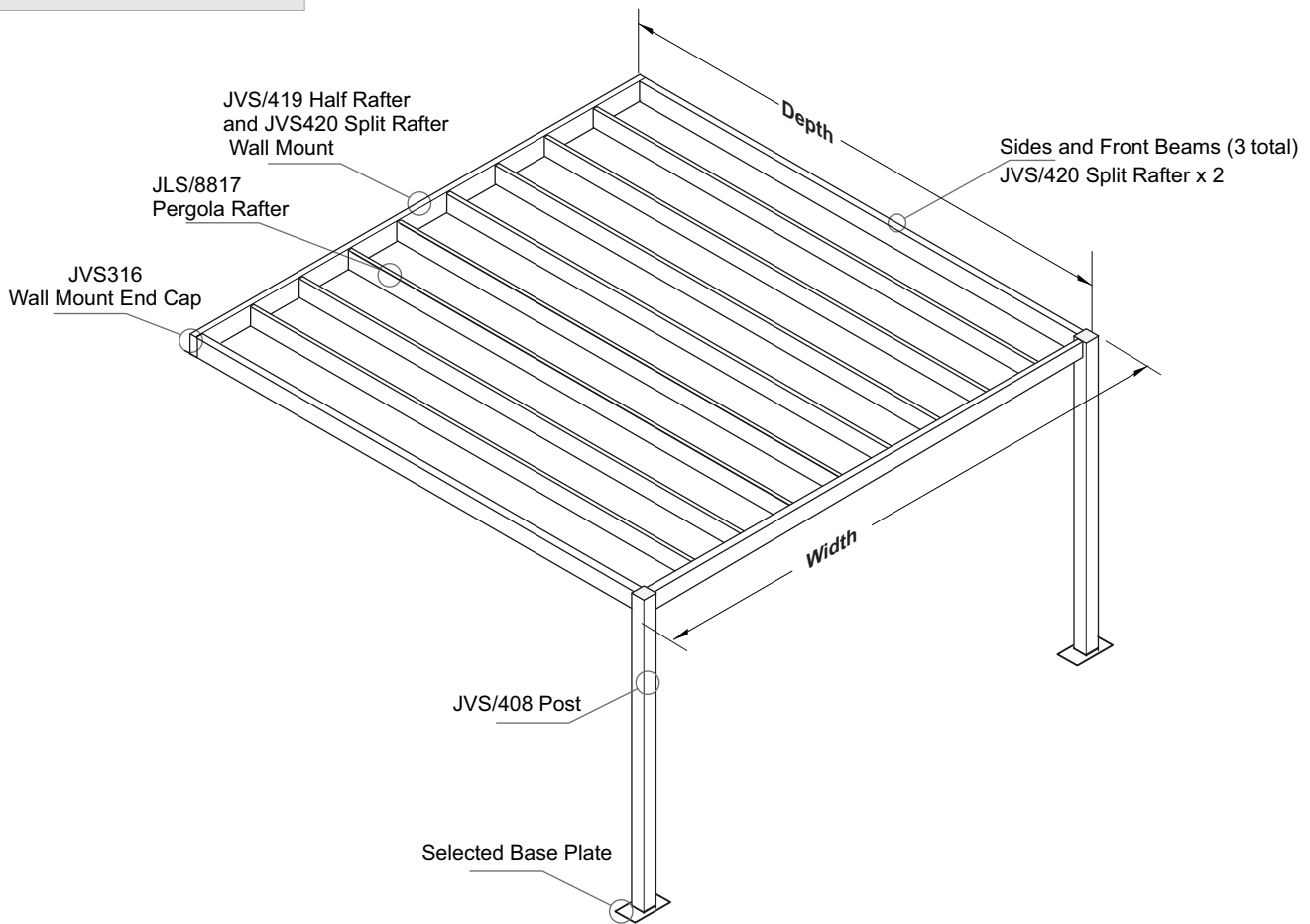

Roofless Types: Options, Rafters either way. Posts, 4 , 2, or 1

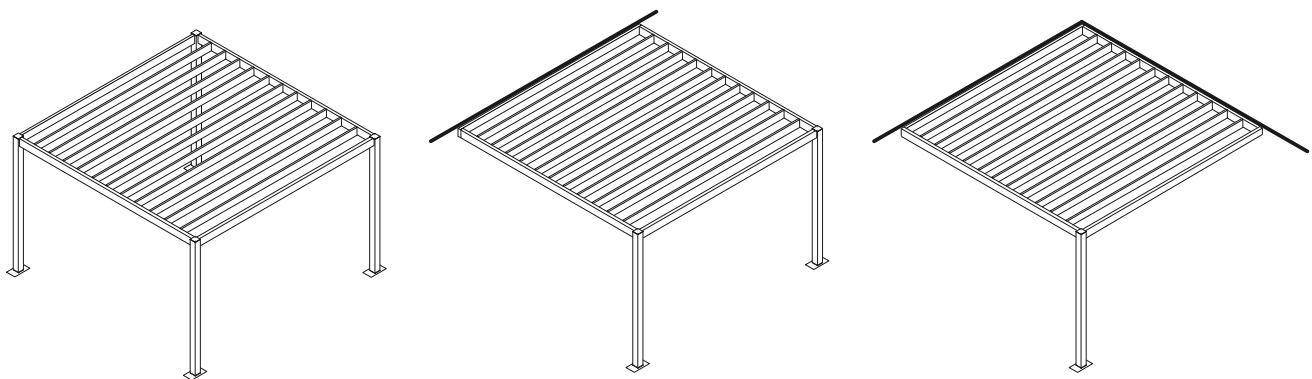

Roofless (no infills) Specifications

Wind Zone	Approx Max Dimensions	Wall fixings
Low	1 x Module Depth 3.6m max Width 3.6m max	Attach using 14g x 50mm min Screws. 45mm min Embedment
Medium		
High		
Very High	Modules can be stacked together to increase Length	
Extra High		

Important Installation notes:

- 1 - The Project Engineer must ensure the structure can support the appropriate loads
- 2 - VelaSun structure shown indicatively only.
- 3 - All Fixings must be Stainless steel
- 4 - Dropdowns not possible
- 5 - Freestanding or Wall mounted configurations available

Juralco VelaSun® Outdoor Living System - Polycarbonate Roof Pergola. Typical Configuration

Polycarbonate Panels Pergola Configuration

Note - Infill Panel Types only
Adjust to give a drainage slope of 5 deg min - 15 deg max

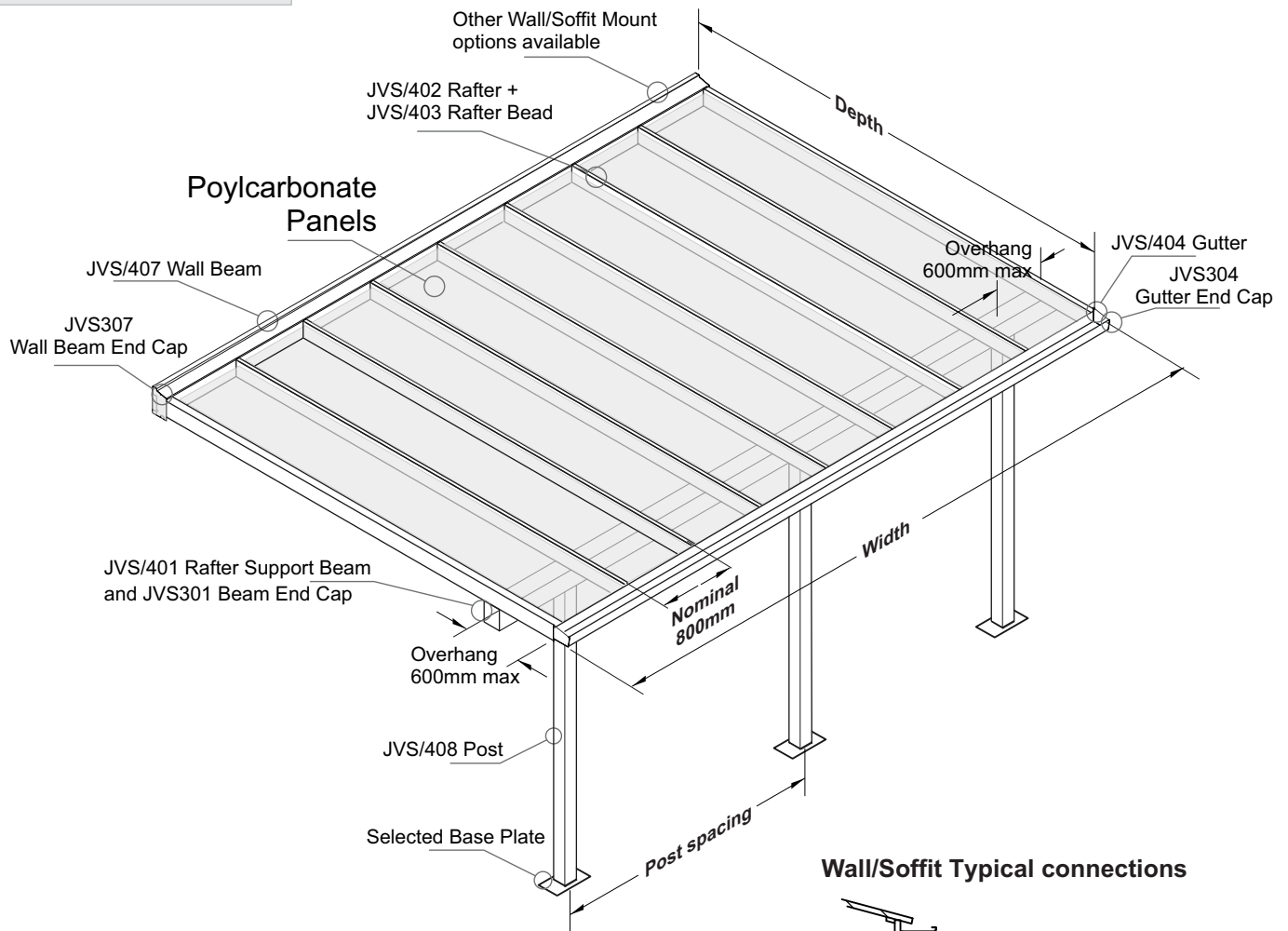

Polycarbonate Panels Infill Specifications

Wind Zone	Depth max m	Width m max (must be multiples of 800, +77)	Distributed Load kN/m	Direct Wall Beam Fixing Screws
Low	4.8	12	2.23	1x14g @500
Medium	4.0		2.48	1x14g @500
High	4.0		3.50	1x14g @500
Very High	3.2		3.60	1x14g @500
Extra High	3		3.65	1x14g @500

Posts Specifications

Wind Zone	Spacing max m	Height max m	Uplift kN	Concrete m ³
Up to Very High	3.6	2.9	12.96	0.56
Extra High	3.2		11.66	0.51

Important Installation notes:

- 1 - The Project Engineer must ensure the structure can support the appropriate loads
- 2 - VelaSun structure shown indicatively only.
- 3 - Wind Zones up to and including Extra High
- 4 - Polycarbonate panel nominal 800mm wide.
- 5 - All Fixings must be Stainless steel

Wall/Soffit Typical connections

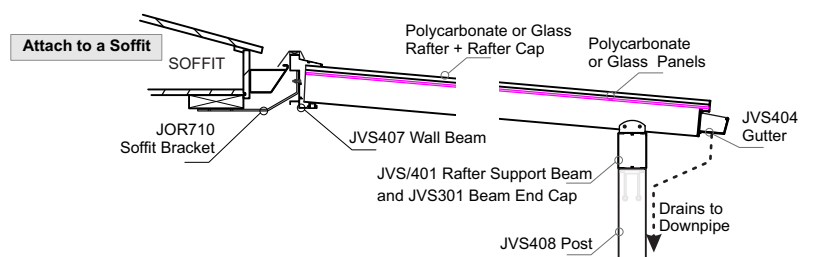
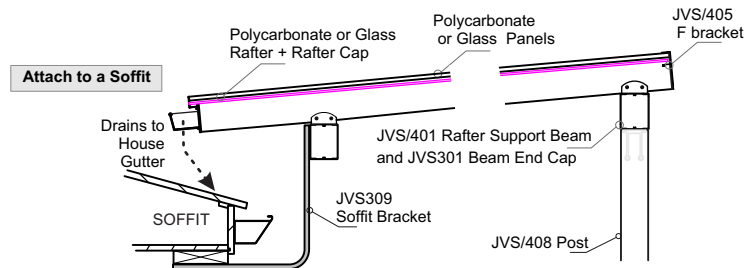
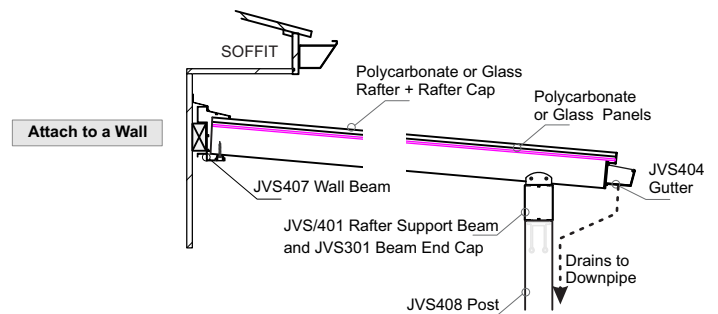

Juralco VelaSun® Outdoor Living System - Glass Roof Pergola. Typical Configuration

Glass Panels Pergola Configuration

Note - Infill Panel Types only
Adjust to give a drainage slope of 5 deg min - 15 deg max

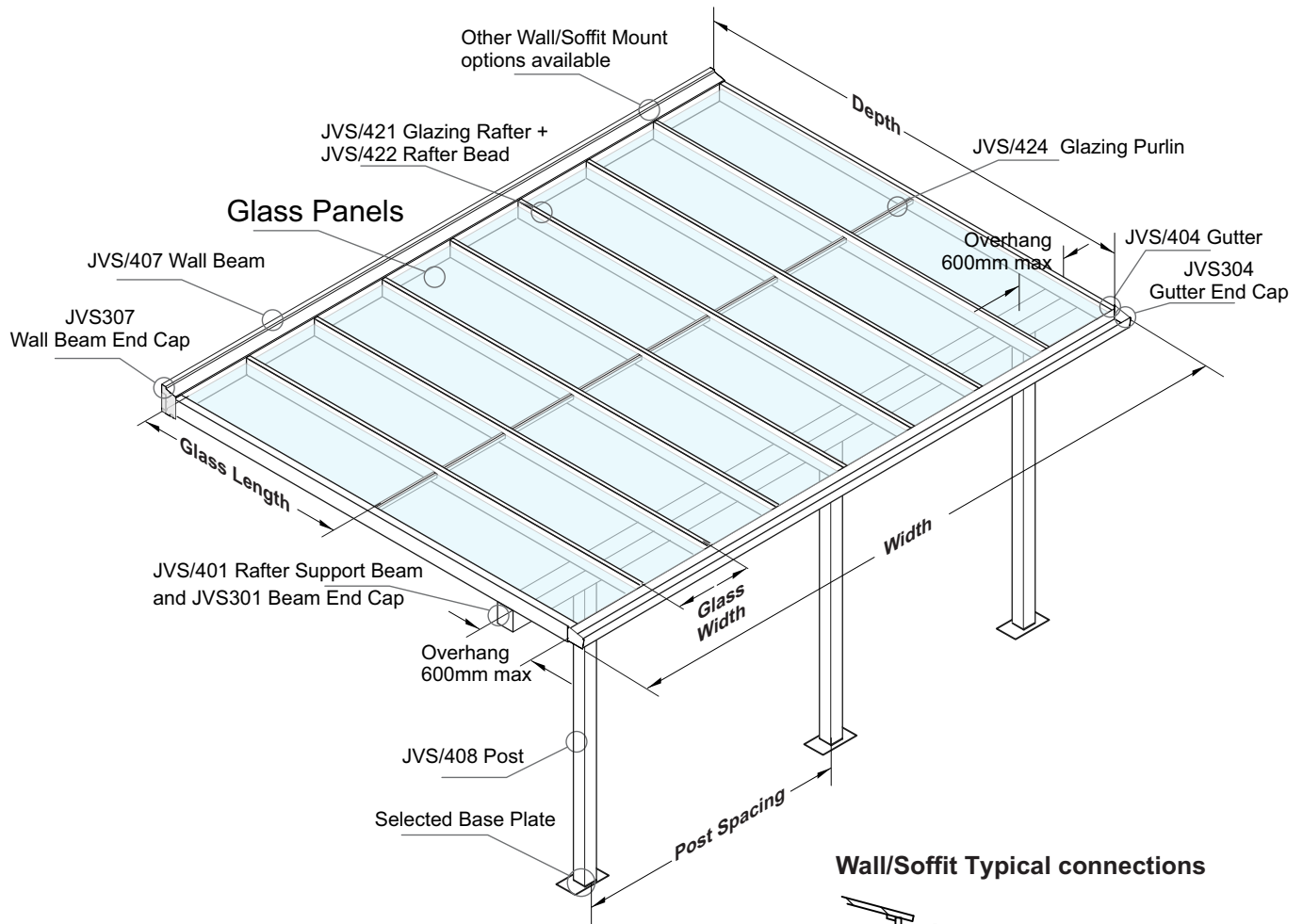

Glazing Infill Specifications

Wind Zone	Depth max m	Width max m	Distributed Load kN/m	Direct Wall Beam Fixing Screws
Low	4.0	12	1.86	1x14g @500
Medium	3.6		2.23	1x14g @500
High	3.2		2.80	1x14g @500
Very High	3		3.38	1x14g @500
Extra High	2.9		3.52	1x14g @500

Posts Specifications

Wind Zone	Spacing max m	Height max m	Uplift kN	Concrete m ³
Up to Very High	3.6	2.9	12.15	0.53
Extra High	3.2		11.30	0.50

Wall/Soffit Typical connections

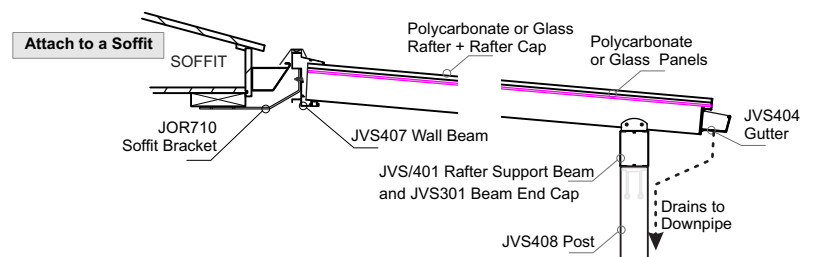
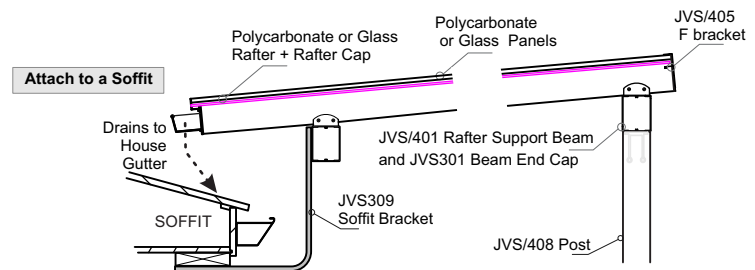
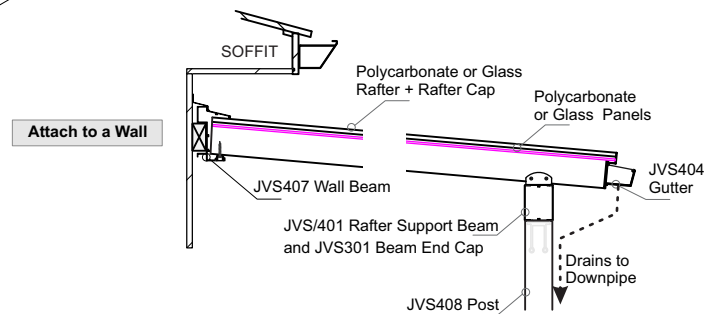

Important Installation notes:

- 1 - The Project Engineer must ensure the structure can support the appropriate loads
- 2 - VelaSun structure shown indicatively only.
- 3 - Wind Zones up to and including Extra High
- 4 - Glass panels 6mm Toughened or 6.4mm Laminated Safety Glass (max 600mm wide) Must be installed by a suitably qualified Glazier. (WGANZ member)
- 5 - All Fixings must be Stainless steel

Juralco VelaSun® Outdoor Living System - Extrusions and Components

For 4mm Polycarbonate Panels

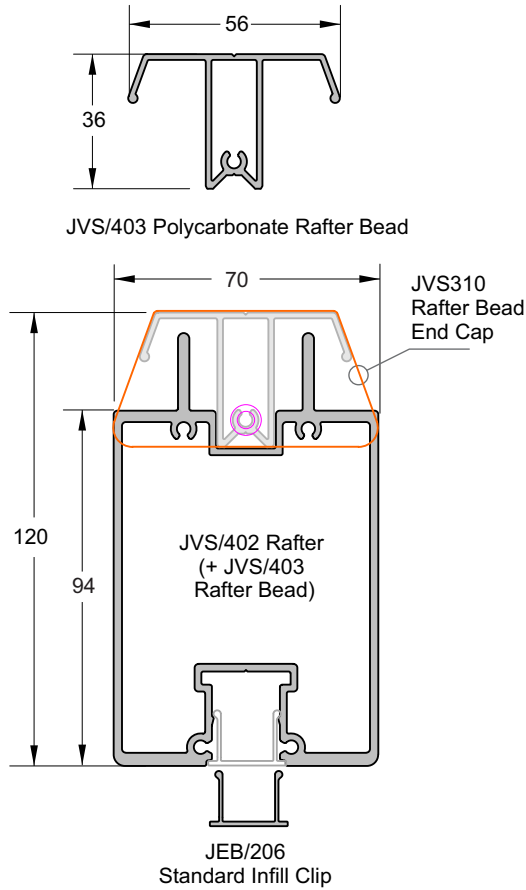

For 6.4mm Laminated Safety Glass or 6mm Toughened Safety Glass Panels

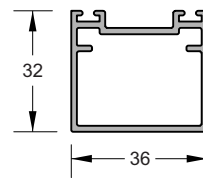
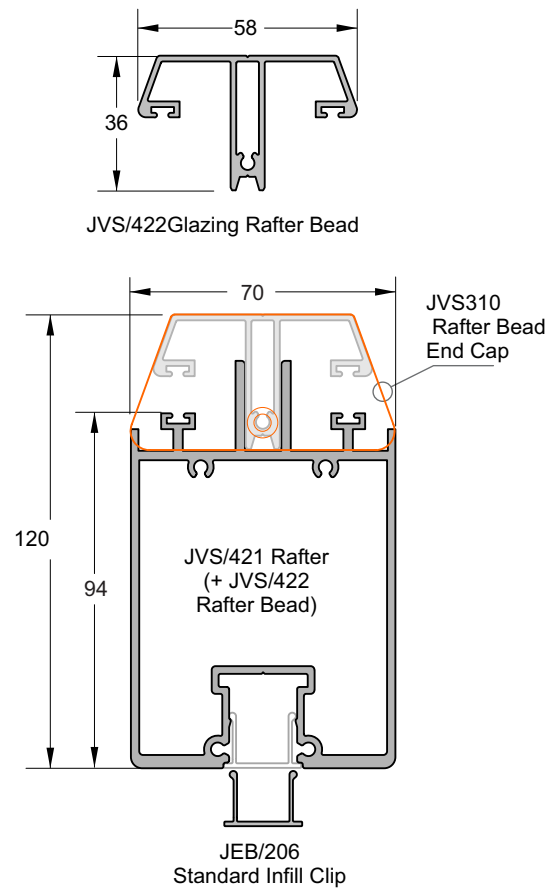

JVS/424 Glazing Purlin

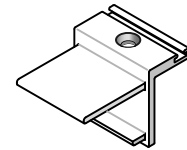

JVS323 Glazing Purlin Connector

JVS321 Glazing Gasket Rafter and Purlin

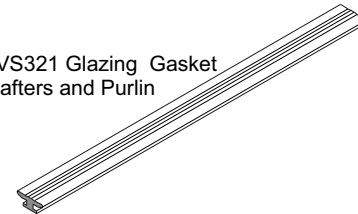

Mini LED Lighting.

Mount the LED and its Translucent Acrylic Infill JEC44 inside the base of the JVS/401, JVS/402 Rafters a replacement for the JEB/206 Std Infill clip. Also applies to the JVS/407 Wall Beam LED lighting supplied by others

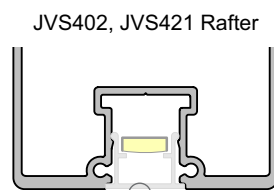

LED Lighting

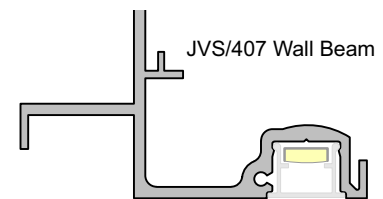

JVS/407 Wall Beam

Juralco VelaSun® Outdoor Living System - Extrusions

JLS/8817 Pergola Rafter

Mini LED Lighting.
 Mounting channel JGF/2218 24x18 and Translucent Acrylic Infill JEC44
 Mount externally to JLS/8817 Pergola Rafters using the Mounting channel.
 LED supplied by others

JLS/8817 Pergola Rafter

JA116 Finishing Angle

JVS/401 Rafter Support Beam (6060 T6)

JVS/419 Half Rafter Wall Mount

JVS/420 Half Rafter

JVS/408 Post

JVS/407 Wall Beam

JVS/409 Wall Beam Cover

JEB/206 Standard Infill Clip

JVS/405 F bracket
 Fasteners
 - 8g ST x 1/2 Pan
 @ 4 per Rafter

JVS/404 Gutter

Juralco VelaSun® Outdoor Living System - Components

JVS306
Rafter End Cap
(Polycarbonate)

94x70
x 3mm thick

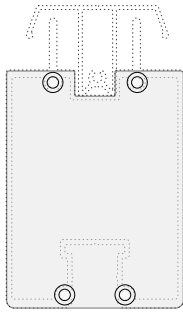

Fasteners - 8g ST x 3/4 CSK

JVS302
Rafter End Cap
(Polycarbonate)

120x70
x 3mm thick

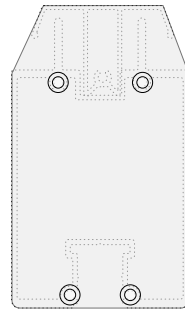

Fasteners - 8g ST x 3/4 CSK

JVS324
Rafter End Cap.
(Glass)

94x70
x 3mm thick

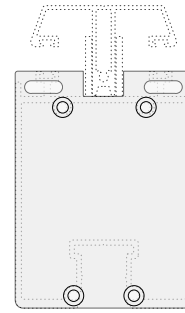

Fasteners - 8g ST x 3/4 CSK

JVS304
Gutter End Cap

84x89
x 2mm thick

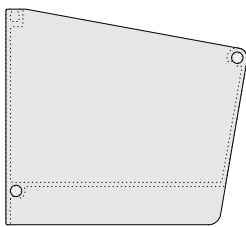

Fasteners - 8g ST x 1/2 Pan

JVS310
Rafter Bead End Cap

36x69
x 2mm thick

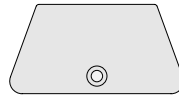

Fasteners - 8g ST x 3/4 CSK

JVS301
Rafter Support Beam
End Cap

120x95
x 3mm thick



Fasteners - 8g ST x 3/4 CSK

JVS317
Split Rafter End Cap

94x70
x 2mm thick



Fasteners - 8g ST x 1/2 Pan

JVS311
Post End Cap

90x90
x 3mm thick

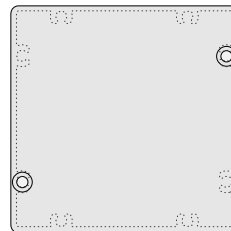

Fasteners - 8g ST x 3/4 CSK

JVS307
Wall Beam End Cap

180x110
x 2mm thick

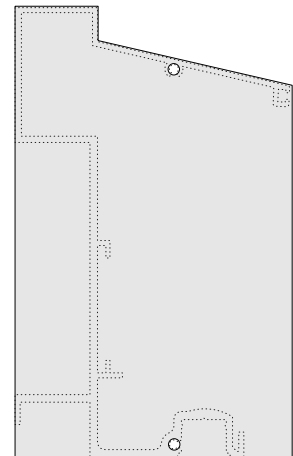

Fasteners - 8g ST x 1/2 Pan

JVS316
Wall Mount End Cap

102x65
x 3mm thick



Fasteners - 8g ST x 3/4 CSK

JVS318
Rafter Bead, Squared
End Cap

38x71
x 2mm thick
(LH or RH)

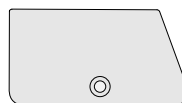

For use with JA116, 40x40 finishing angle

Fasteners - 8g ST x 3/4 CSK

JC231/Black Seal
13mm Mohair

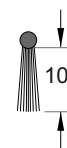

Juralco VelaSun® Outdoor Living System - Components

JVS314
4 Hole Base Plate

180x120
x 12mm thick

14g C/S Holes

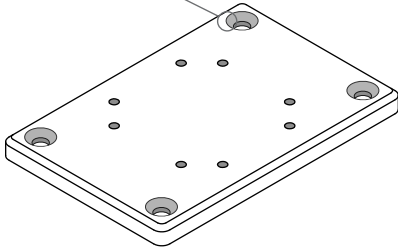

Post/Baseplate Screw
JVBHTSCREW/50x10

JVS312
2 Hole Base Plate

180x100
x 12mm thick

13mm dia Holes

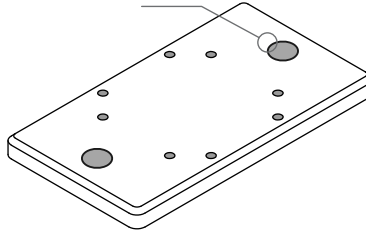

Post/Baseplate Screw
JVBHTSCREW/50x10

Attach Post To Rafter
Support Beam

JVS308
Post Connector
85x85x97 high

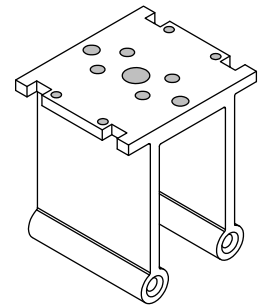

Fasteners - 8g ST @ 4x 25

JOR628 Marley 65
Dropper Cover

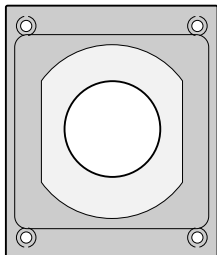
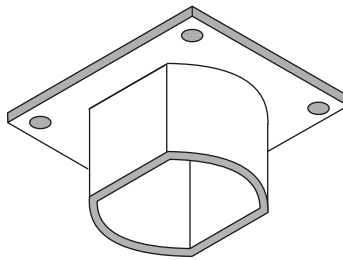

Plate 100x84 Hole 38mm dia

JOR646 PVC Marley Dropper
(shown with Dropper Cover)



JVS303
Rafter Mounting Bracket

85x77
x45mm high

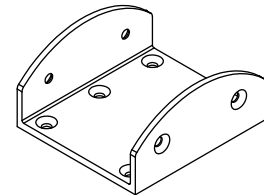

Top Fixing to JVS401Rafter
Support Beam. @ 6 x 10g ST x 1/2 CSK
Side Fixing to JVS402 Rafter
@ 4 x 10g ST x 1/2 CSK

JVS315
Split Rafter Bracket

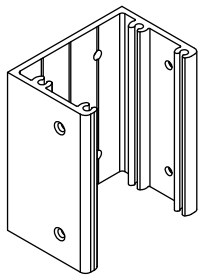

66x41 x 79 high

JVS311
Post Top Cap

90x90
x 2mm thick

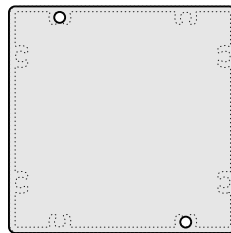

Fasteners - 8g ST x 1/2 Pan

JVS319 Wall Beam Seal



Post/Baseplate Screw
JVBHTSCREW/50x10

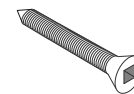

50mm SS High Tensile
ST C/S sq drive screw

JOR710
Soffit Bracket

JOR710/SS Soffit Bracket
All ex 6mm SS
340 long x 135 high x 300 wide

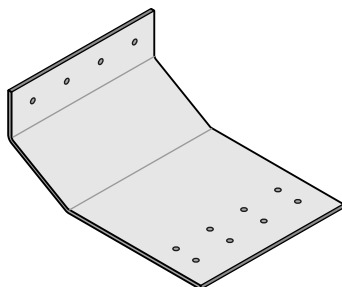

Fasteners - 14g ST x 1 Hex
@ 12 x per bracket

JVS309
Soffit Bracket

JVS309 Soffit Brkt
All ex 10mm SS
360 long x 380 high x 75 wide

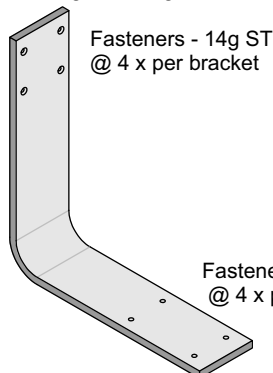

Fasteners - 14g ST
@ 4 x per bracket

Fasteners - 14gx50 SS
@ 4 x per bracket

JVS313
Beam T Joiner

JVS313 Beam T Joiner
All ex 6mm SS
300 long x 108 high x 90 wide

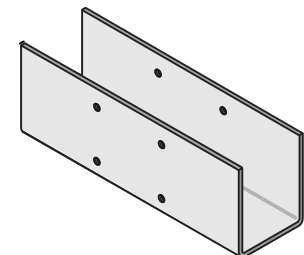

Sides 8 x M8 threaded Holes
Base 4 x M6, 2 x M8 and 1 x M12

Juralco VelaSun® Outdoor Living System - Fasteners (Not supplied)

Necessary Fasteners for a VelaSun structure

Item Part No	Item Description	Fastener	Needed to Attach together
JVS314 or JVS312	Base Plates	JVBHTSCREW/50x10. High Tensile screws	Post to Baseplate x 8
JVS308	Post Connector	M8 x 25 316 SS CSK Socket Screws	Beams to Top of Post x 4
		6x 10g x 1/2 316SS ST Pan Screws	Post Connector into the Beam
JVS313	Beam Joiner	M8 x 30 316 SS Button Socket Screws M6 x 30 316 SS Button Socket Screws	Joining Beams. 8 x M8, 4 x M6
JOR710	Soffitt Bracket	14g x 25 316 SS Bolts	Wall Brkt to Soffitt Brkt x 4
		14g x 25 316 SS ST Screws	Beam to Soffitt Brkt x 4
		14g x 50 316 SS CSK Head Screws	Soffitt Brkt to Soffitt x 8
JVS303	Rafter Mounting Bracket	10g x 1/2 316 SS CSK Head Screws	Rafter to Bracket x 4
			Bracket to Beam x 6
JVS310	Rafter Bead End Cap	8g x 25 316SS CSK ST	End Cap to Rafter Bead x 1
JVS402	Rafter	14g x 20 316SS Pan	Rafter to Wall Beam x 2
JVS405	F Bracket	8g x 12 316SS Pan ST	Per Rafter x 4
JVS306	Rafter End Cap	8g x 20 316SS CSK ST	End Cap to Rafter x 4
JVS423	Rafter End Cap (Glazing)	8g x 20 316SS CSK ST	End Cap to Rafter x 4
JVS301,304,307, 310, 311	All other End Caps	8g x 12 316SS Pan ST	

Juralco VelaSun® Outdoor Living System - Assemblies/Joints - Roofless Types

Note - ROOFLESS Types are normally installed Horizontal

Rafters Attach to Wall (Backside)

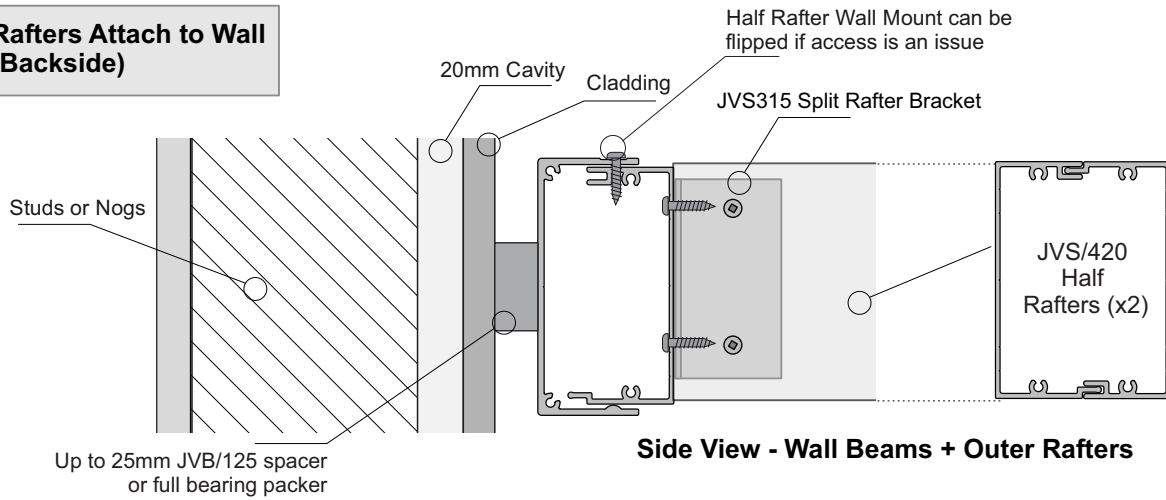

Side View - Wall Beams + Outer Rafters

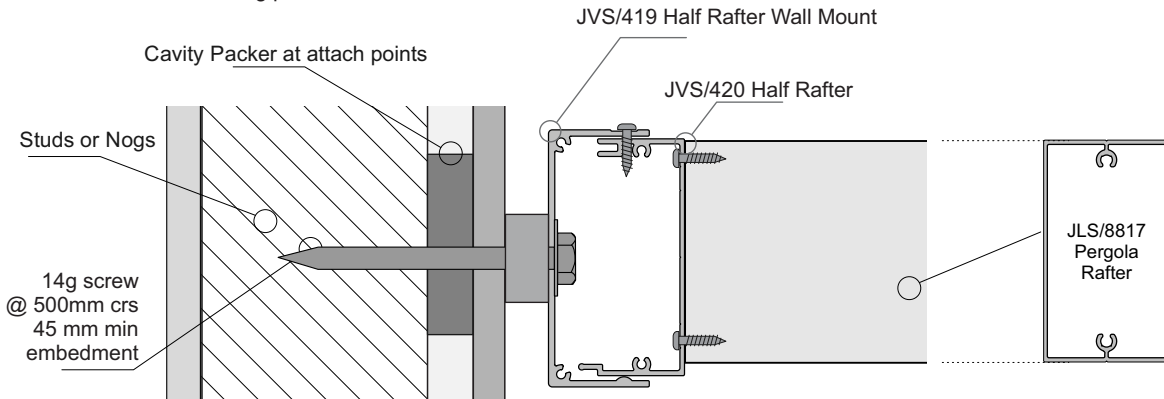

Side View - Wall Beams attach + Inner Rafters

Rafters Attach to Post (Frontside)

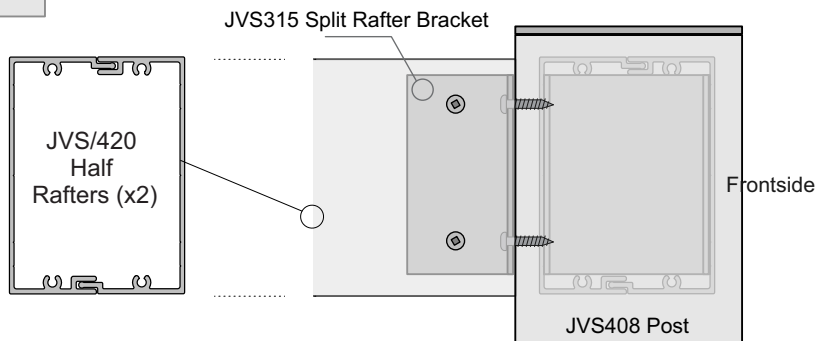

Side View - Outer Rafters + Post attach

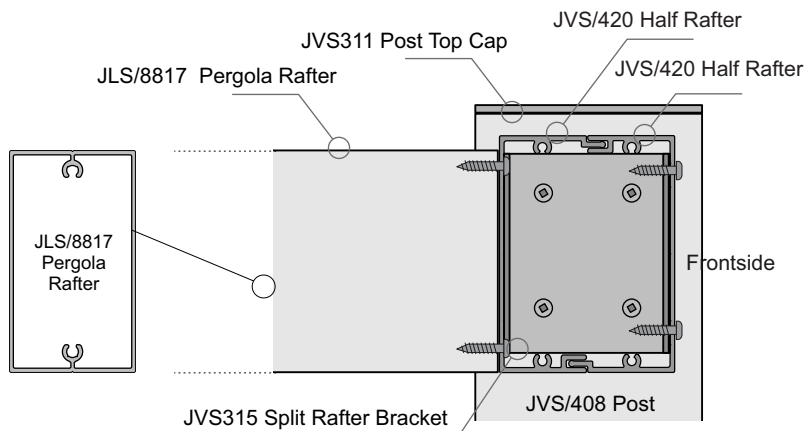

Side View - Inner Rafters + Attach to Front Beam

Juralco VelaSun® Outdoor Living System - Asemblies/Joints - Roofless Types
Note - ROOFLESS Types are normally installed Horizontal, ie 0 deg slope away from Wall

**Outer Beams Attach to Post
(Frontside)**

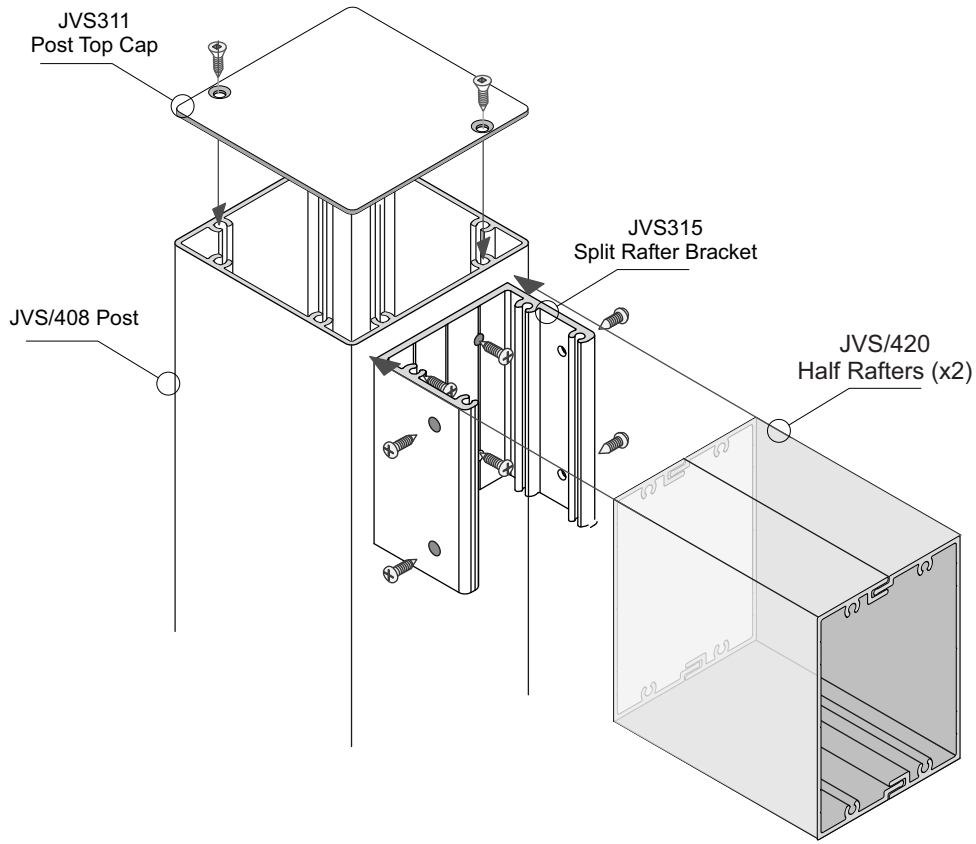

Juralco VelaSun® Outdoor Living System - Mounting to Walls - Roof PANEL Type

Panel Type Beam Attach to Wall

Important Installation notes:

- 1 - The Project Engineer must ensure the structure can support the appropriate loads
- 2 - Substructure shown indicatively only
- 3 - 14g Screw engagement into studs 45mm. All Screws predrill 6mm holes
- 4 - Bond all Screws with SIKA Supergrip30 to full depth
- 5 - All Fixings must be Stainless steel

Cavity Fixing

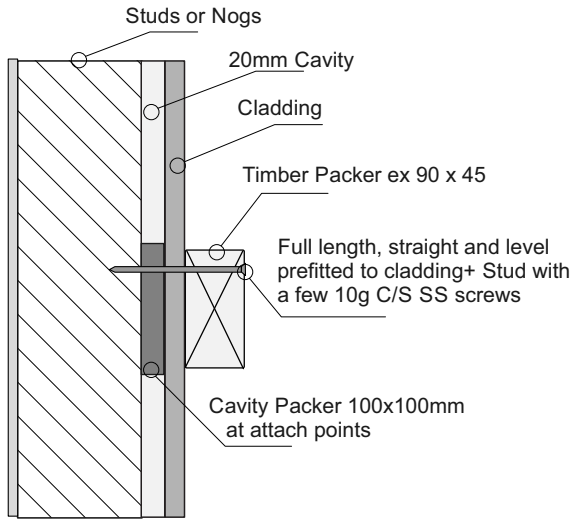

Direct to Weatherboard Fixing

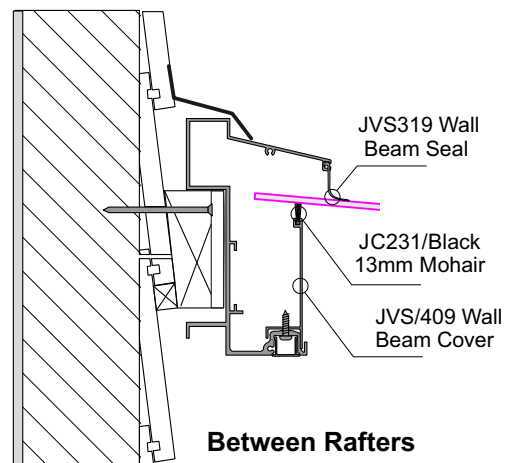
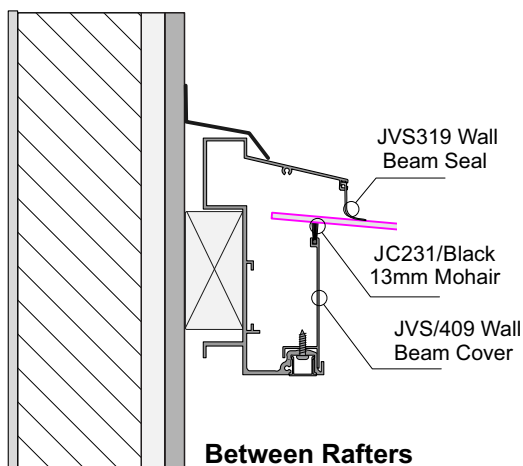
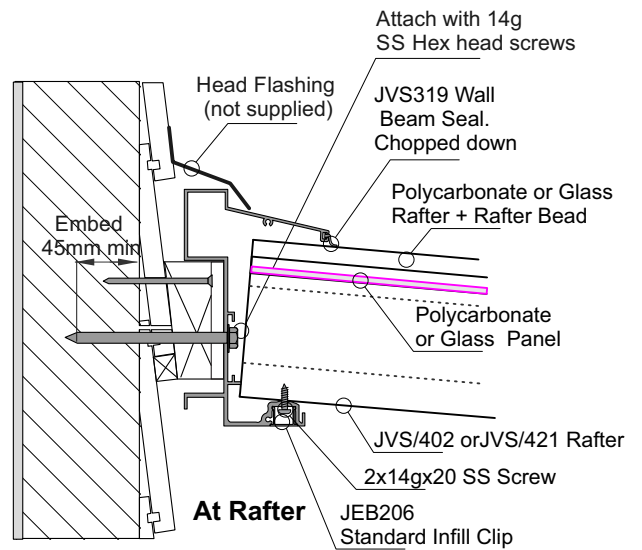
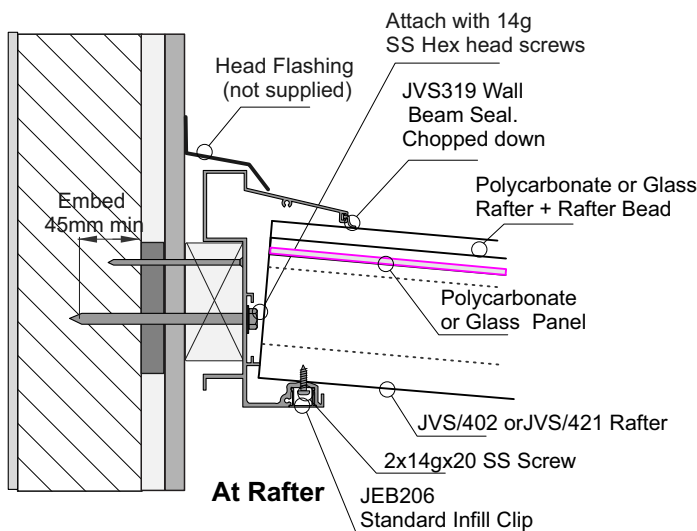
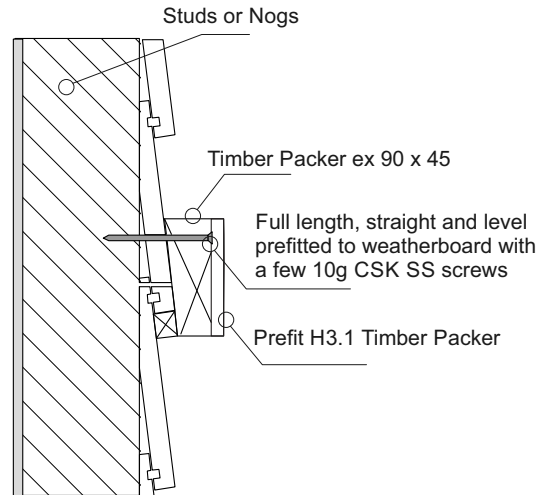

Juralco VelaSun® Outdoor Living System - Mounting Panels to Rafters - Roof PANEL Type

Polycarbonate Panel + Mounting

All Preformed Standing Seams, both long edges
 JVS/P4824 4mm Grey Polycarbonate Panel 800 x 2400mm
 JVS/P4828 4mm Grey Polycarbonate Panel 800 x 2800mm
 JVS/P4832 4mm Grey Polycarbonate Panel 800 x 3200mm
 JVS/P4840 4mm Grey Polycarbonate Panel 800 x 4000mm
 JVS/P4848 4mm Grey Polycarbonate Panel 800 x 4800mm

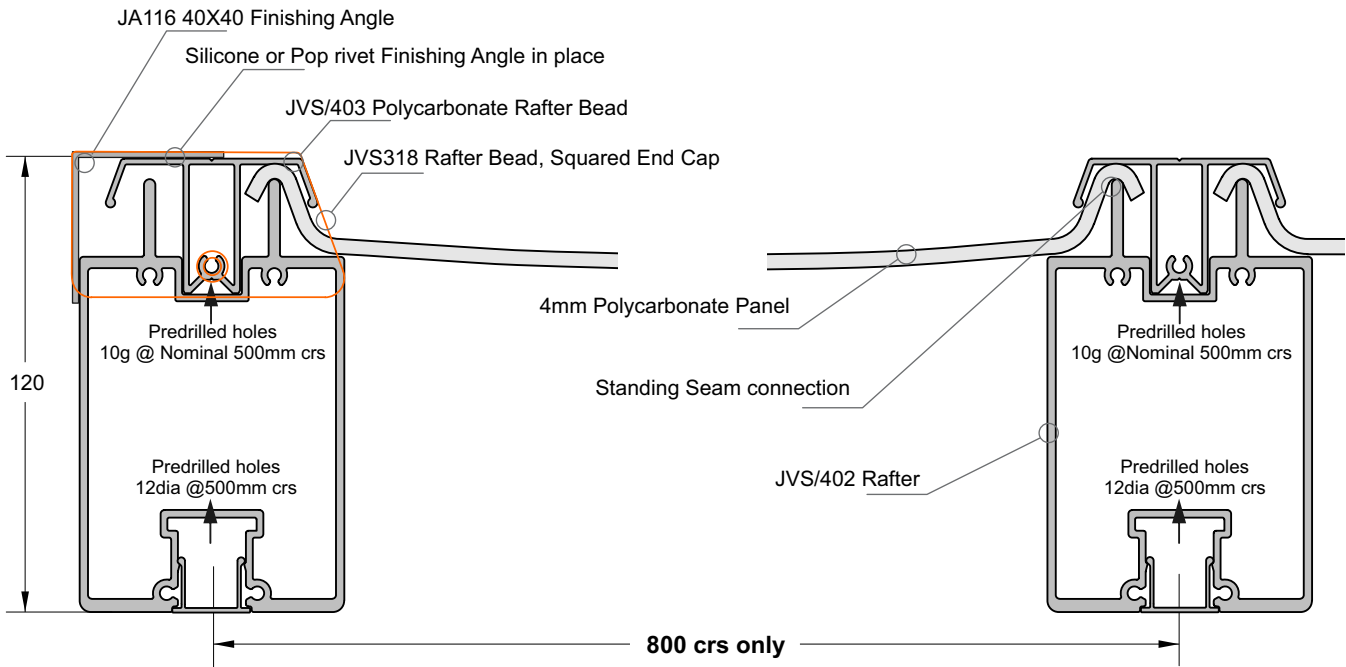

Glass Panel + Mounting

Overhead Glass type to be in accordance with NZS 4223.4:2008

6mm Toughened Glass
 or 6.4mm Laminated Safety Glass Panels
 Max Panel Length 2440mm

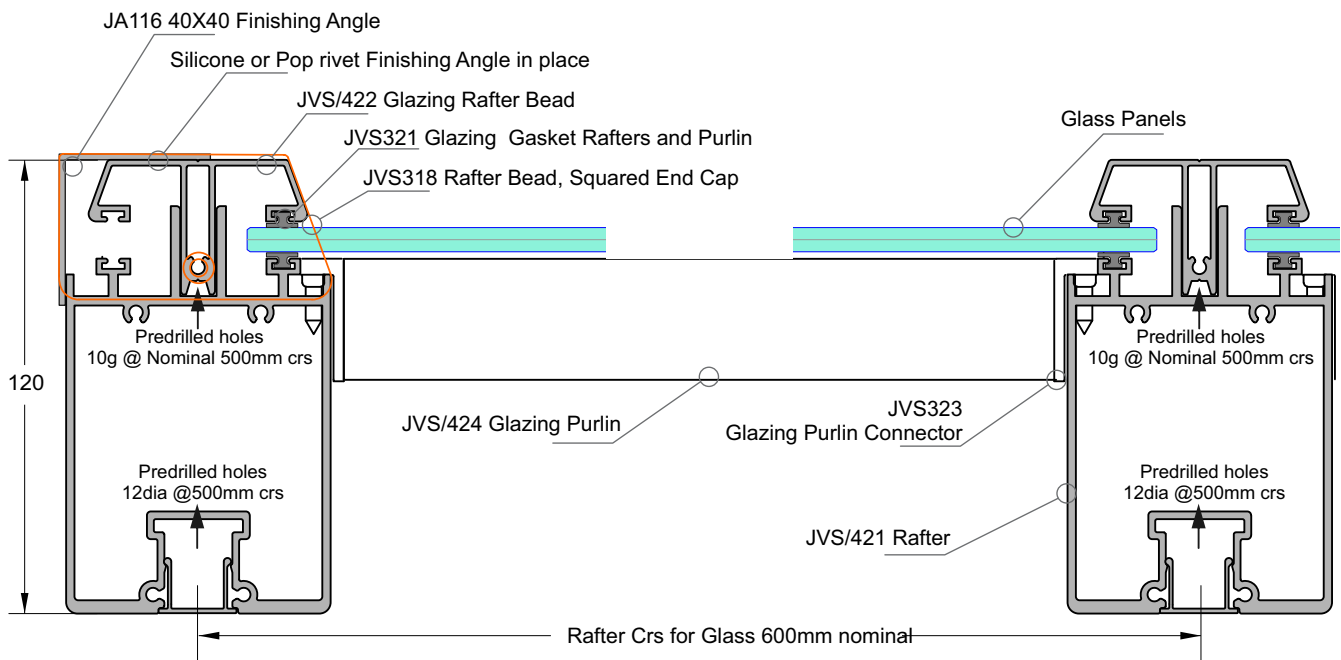

Juralco VelaSun® Outdoor Living System - Mounting to Soffit - Roof PANEL Type

Important Installation notes:

- 1 - The Project Engineer must ensure the structure can support the applied load by the Velasun as specified on page 7, 8
- 2 - Substructure shown indicatively only
- 3 - All fixings must be Stainless steel
- 4 - Cantilevered soffit brackets are expected to flex under wind load

Notes:

- 1 - Applies to Soffit overhangs of 400mm or less. You will need site specific Engineering if greater than 400mm

1 - Soffit Strengthening Timber Plate Attach Details

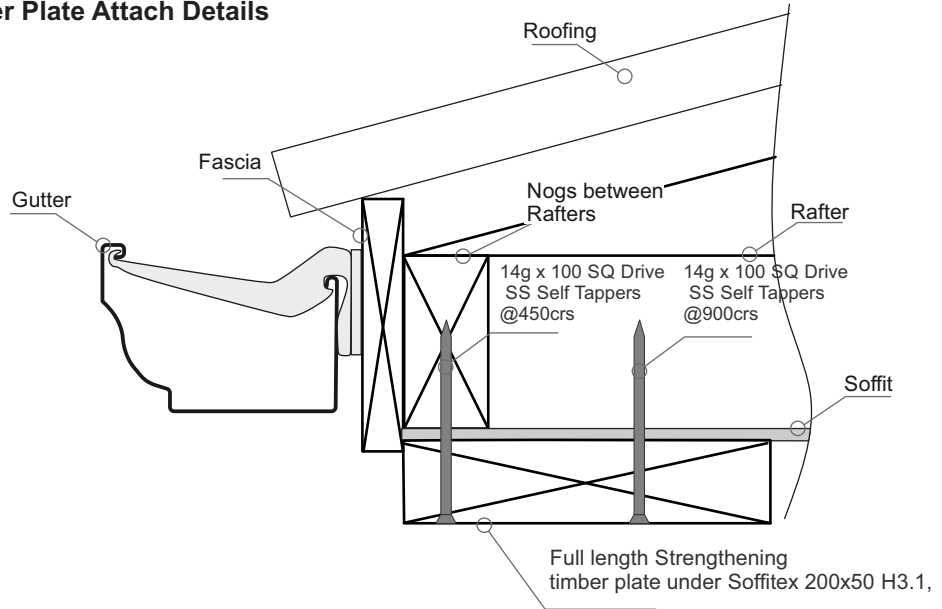

2 - JOR710 Soffit Bracket Attach Details - Attach to Wall Bracket

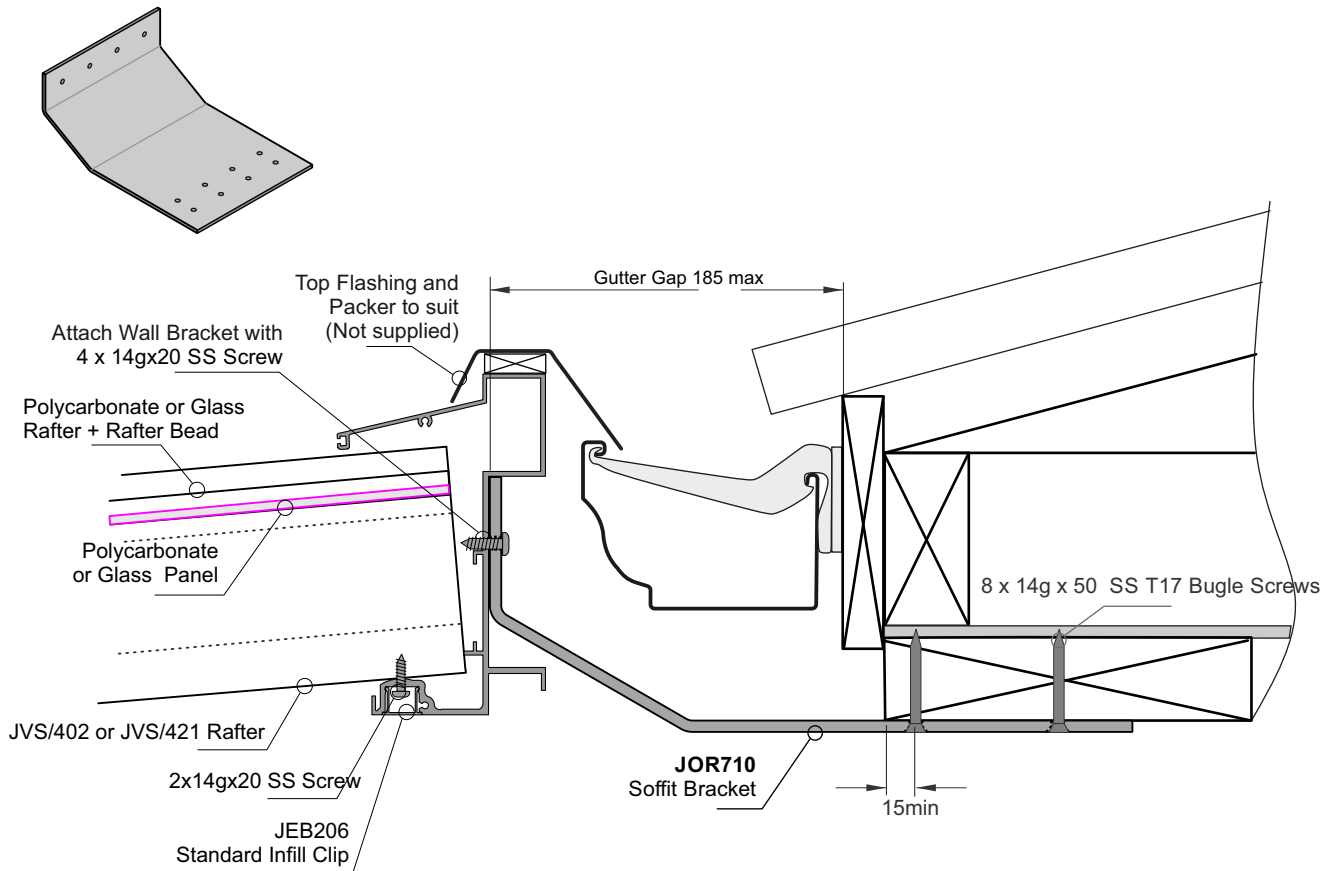

Juralco VelaSun® Outdoor Living System - Mounting to Soffit - Roof PANEL Type

Important Installation notes:

- 1 - The Project Engineer must ensure the structure can support the applied load by the Velasun as specified on page 7, 8
- 2 - Substructure shown indicatively only
- 3 - All fixings must be Stainless steel
- 4 - Cantilevered soffit brackets are expected to flex under wind load

Notes:

- 1 - Applies to Soffit overhangs of 400mm or less. You will need site specific Engineering if greater than 400mm

1 - Soffit Strengthening Timber Plate Attach Details (previous page)

2 - JVS309 Soffit Bracket Attach Details - Attach to Beam

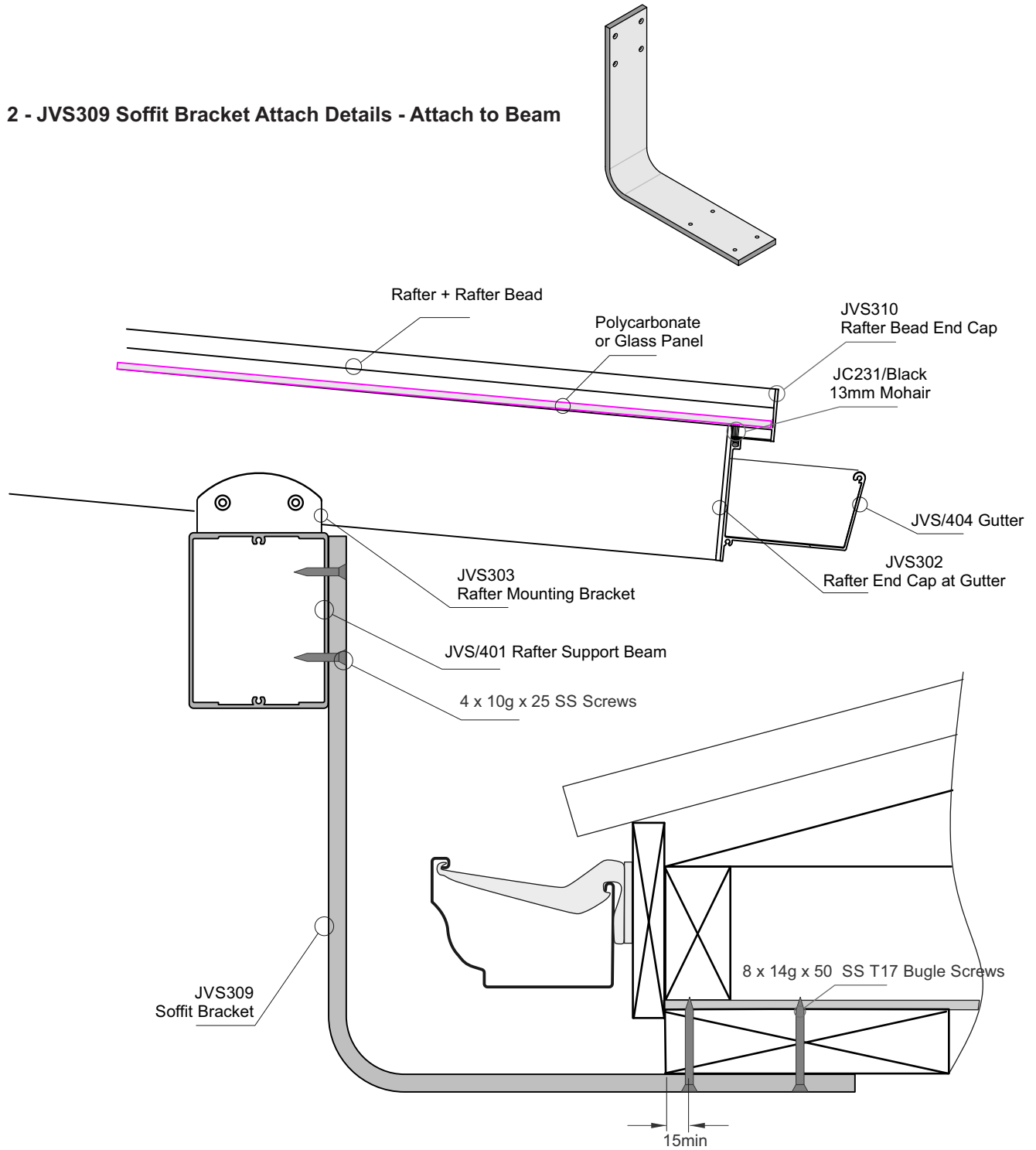

Juralco VelaSun® Outdoor Living System - Soffit Brackets

JOR710 SS Soffit Bracket. All ex 6mm Stainless Steel
Attach the JOR710 to a full length strengthening plate to Nogs and Rafters

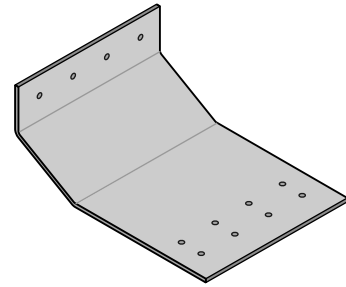
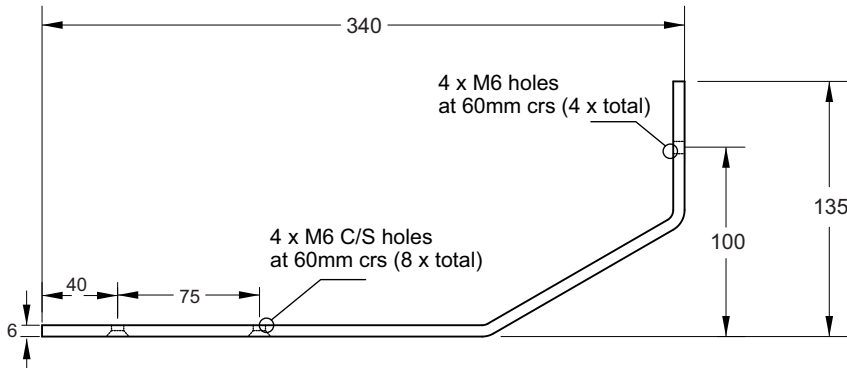

JOR710/SS Soffit Bracket
All ex 6mm SS
300 wide x 135 high x 340 deep.
Powder coated to your colour choice

Soffit Bracket Spacings

Wind Zone	Max Roof Span (m)	JOR710 Bracket Spacings (m)	JVS309 Bracket Spacing (m)
Low	4.8	0.8	0.8
	3.6	1.0	
Medium	4.0	0.8	0.8
	3.0	1.0	
High	4.0	0.8	0.4
	3.6	0.9	
	3.2	1.0	
Very High	3.2	0.8	0.4
	2.8	0.9	
	1.8	1.0	
Extra High	3.0	0.7	0.4
	2.4	0.8	
	1.8	0.9	

Important Installation notes:

- 1 - The Project Engineer must ensure the structure can support the applied load by the Velasun as specified on page 7, 8
- 2 - Substructure shown indicatively only
- 3 - All fixings must be Stainless steel
- 4 - Cantilevered soffit brackets are expected to flex under wind load
- 5 - JVS309 Soffit Brackets have been designed to line up with the rafters

JVS309 SS Soffit Bracket. All ex 10mm Stainless Steel
Attach the JVS309 to a full length strengthening plate to Nogs and Rafters

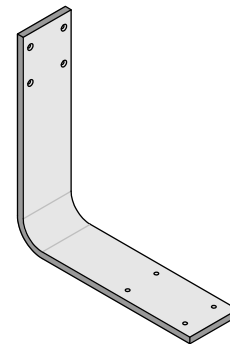
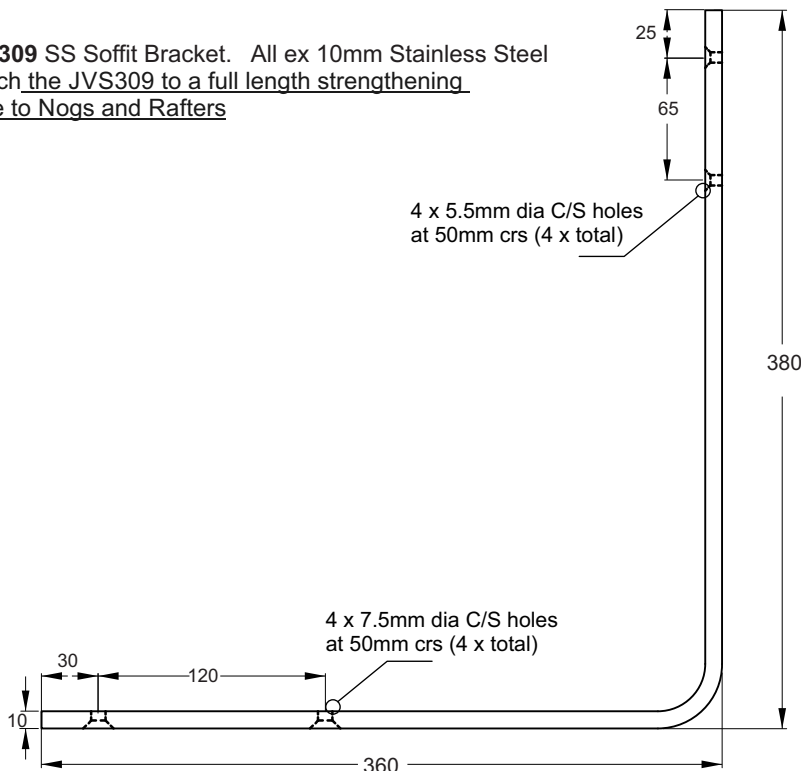

JVS309 SS Soffit Bracket
All ex 10mm SS
75 wide x 380 high x 360 deep
Powder coated to your colour choice

Juralco VelaSun® Outdoor Living System - Assemblies/Joints - **Roof PANEL Type**

Attach Post to Rafter Support Beam

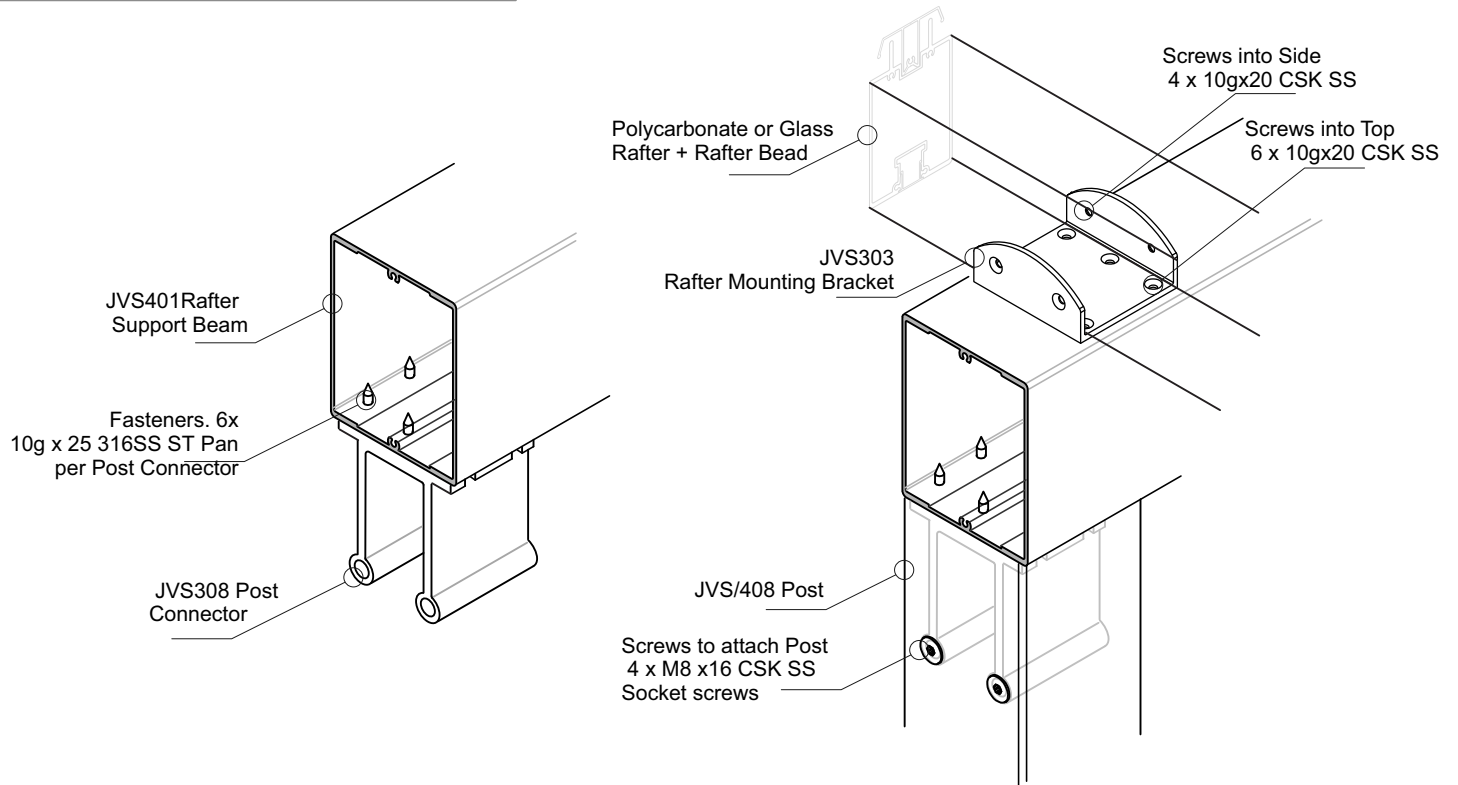

Attach Post to Baseplate

Applies to 2xHole (180x100mm) and 4xHole Baseplates (180x120mm) x 12mm

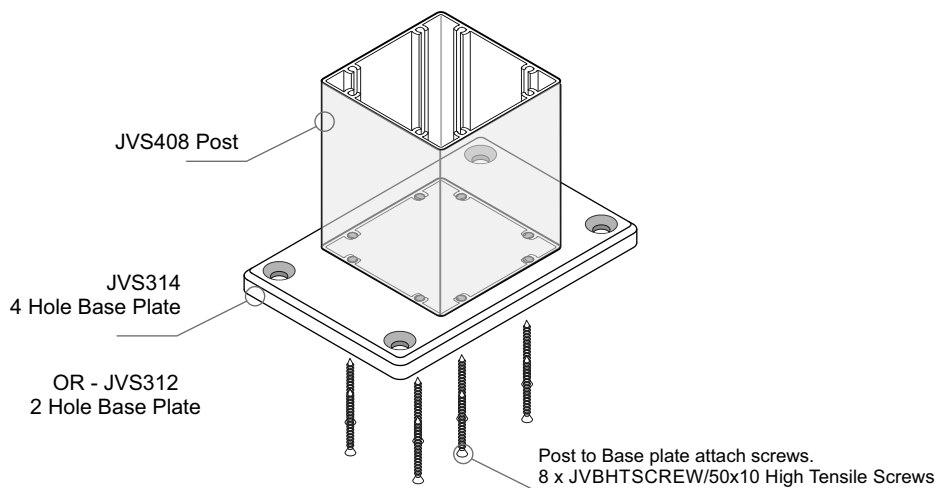

Juralco VelaSun® Outdoor Living System - Assemblies/Joints - Roof PANEL Type

Join Beams at Post

JVS313 Beam T Joiner
All ex 6mm SS
300 long x 108 high x 90 wide
Threaded Holes
Sides 4 x M8 ea side
Base 4 x M6, 2 x M8 and 1 x M12

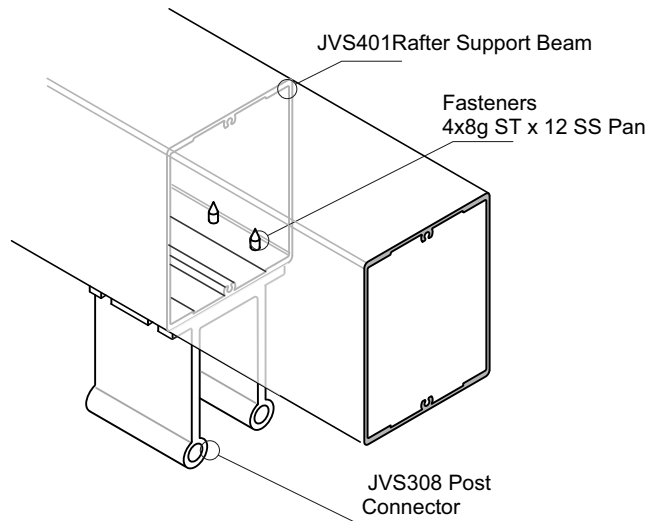
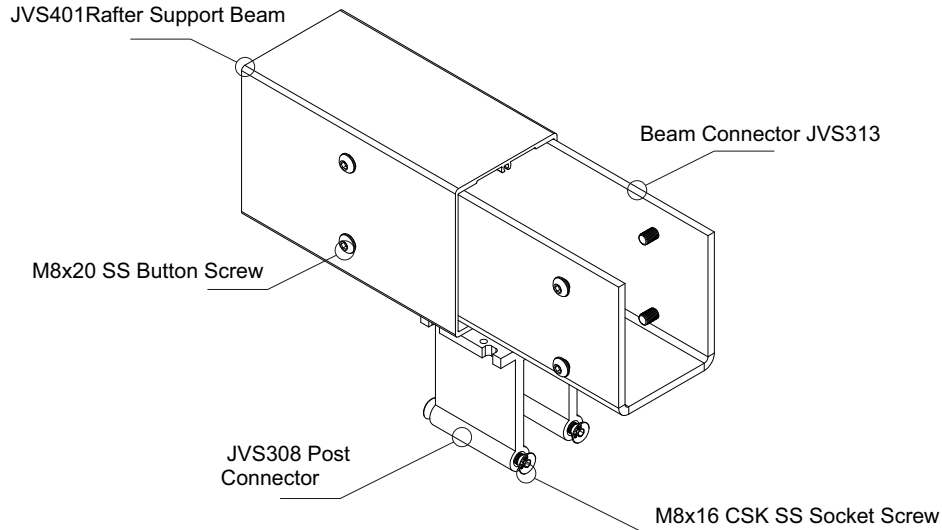
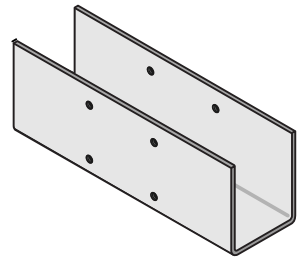

Juralco VelaSun® Outdoor Living System - Assemblies/Joints - Roof PANEL Type

**Panel Type
Gutter and Drainage**

Note - Infill Panel Types only
Adjust to give a drainage slope of min 5 - max 15deg

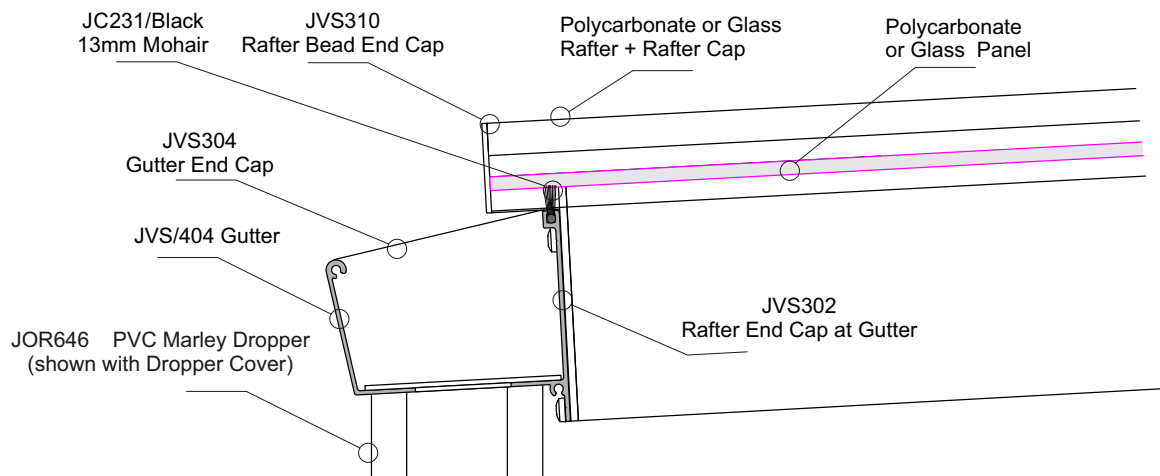
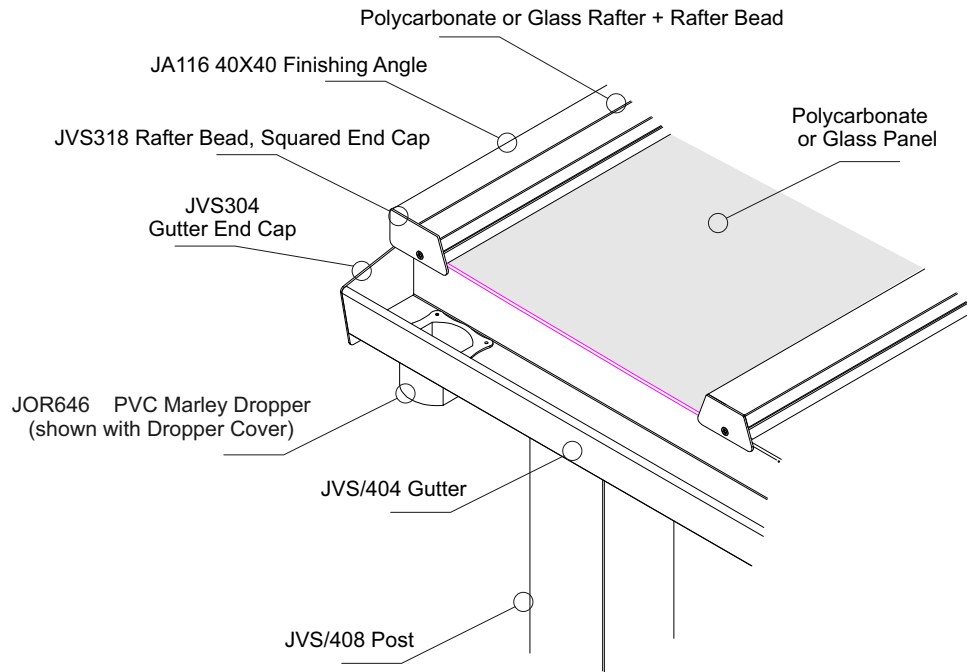

Juralco VelaSun® Outdoor Living System - Assemblies/Joints - Roof PANEL Types

Attach to a Soffit

Note - Infill Panel Types only
Adjust to give a drainage slope of min 5 - max 15deg

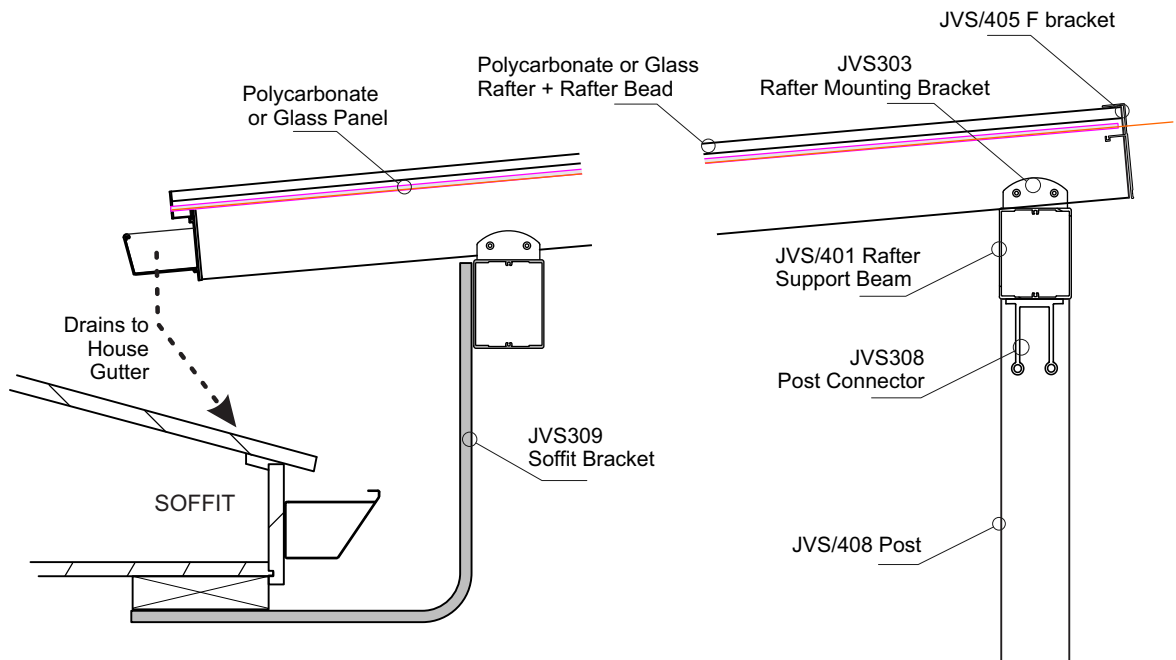

Attach to a Wall

Note - Infill Panel Types only
Adjust to give a drainage slope of min 5 - max 15deg

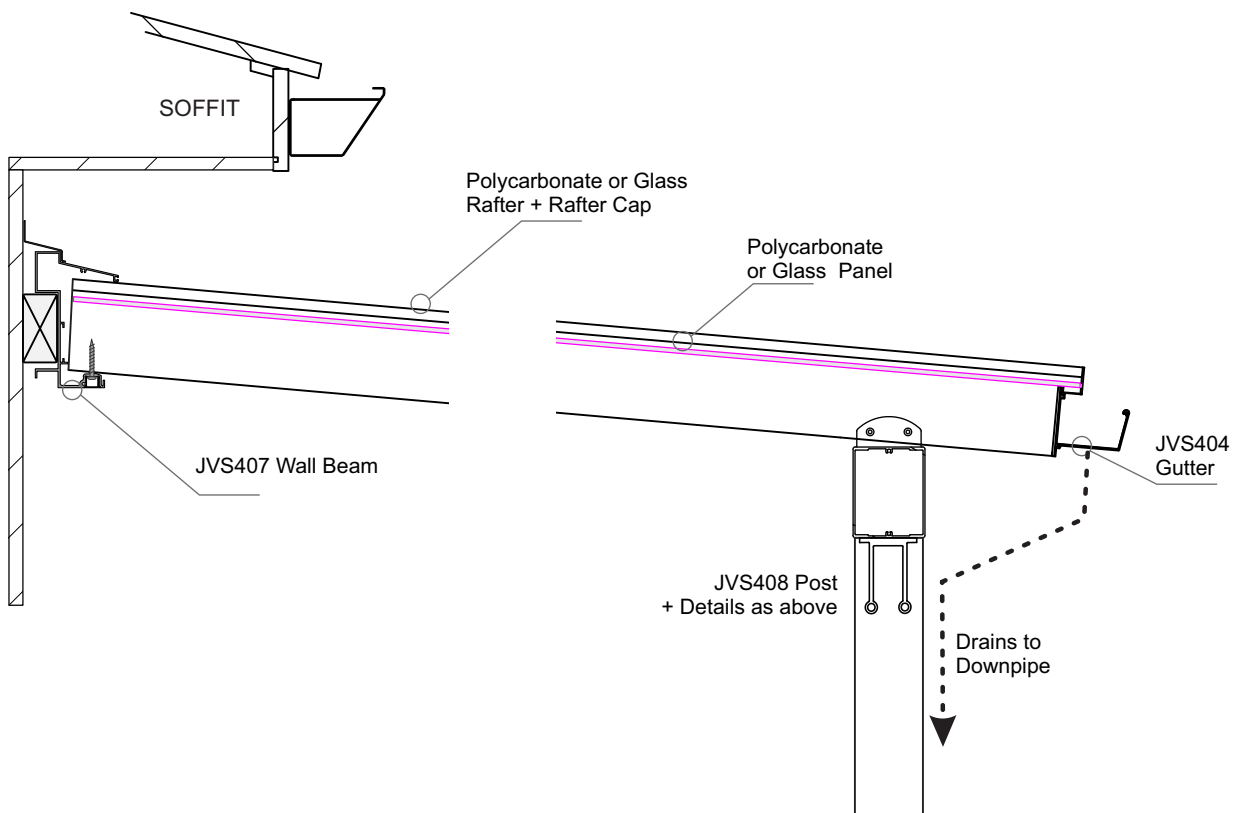

Attach Glass to Purlins, Rafters

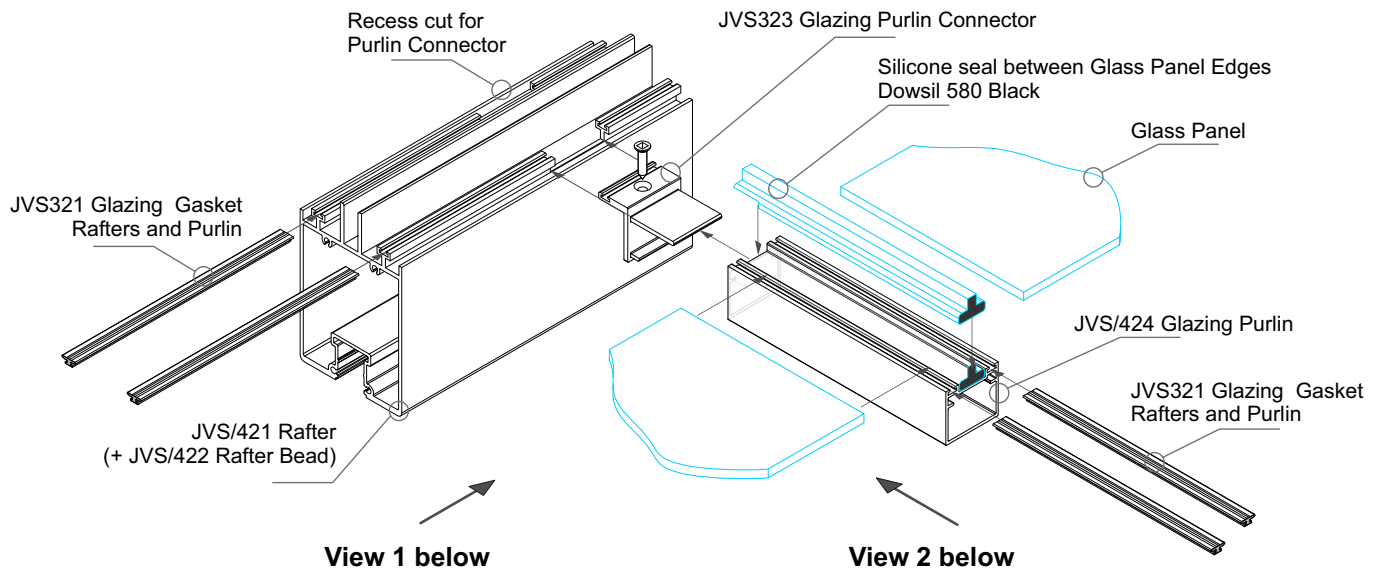

View 1

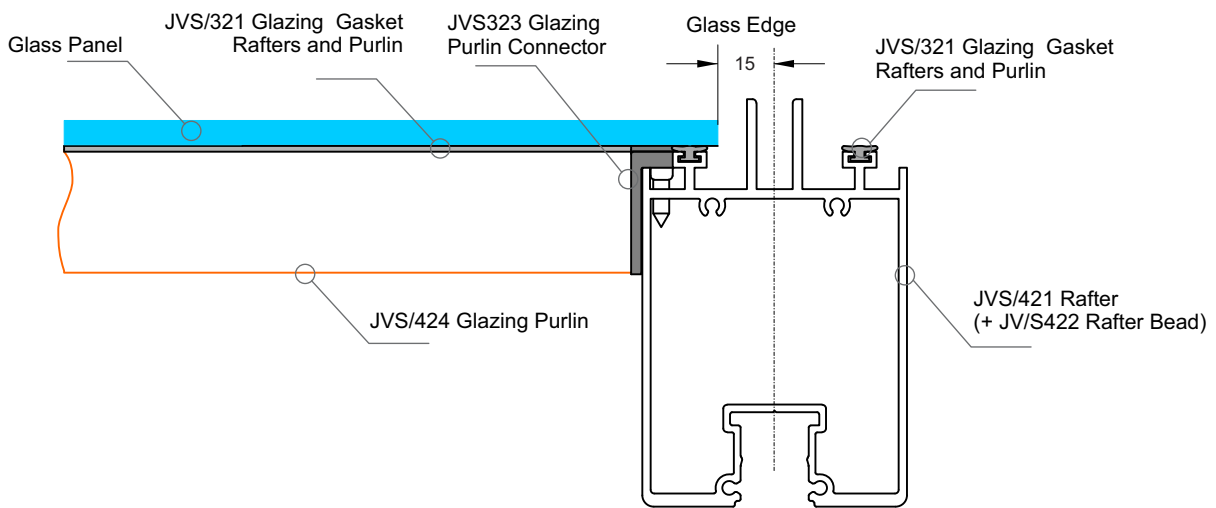

View 2

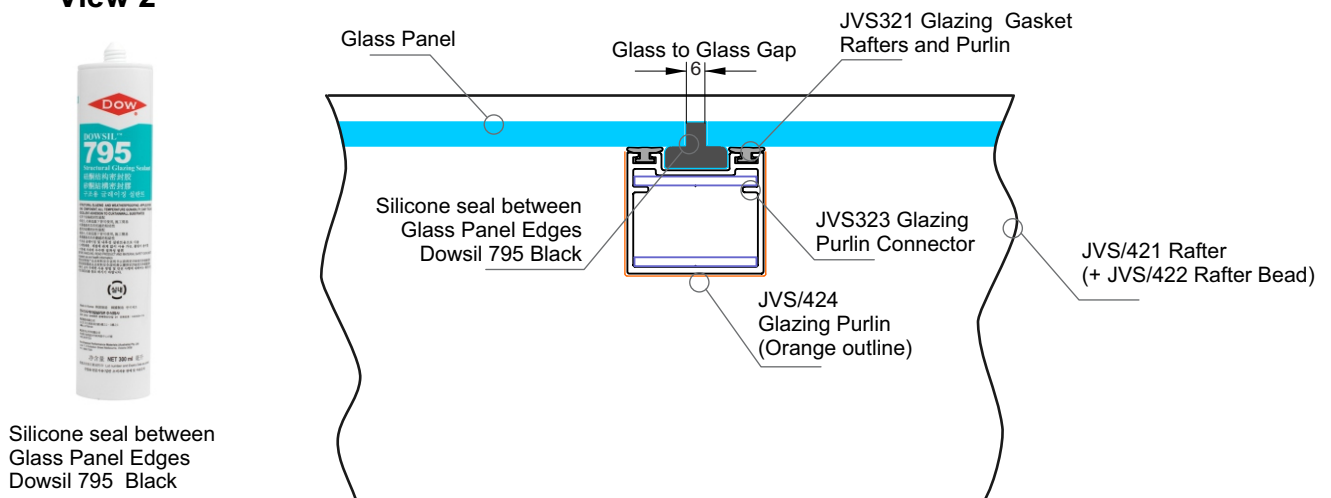

**Juralco VelaSun® Outdoor Living System - Structural - Post attach to Joists (All types)
NZS3604:2011 Connection. Double Boundary Joists**

Typical TOP Fix to Timber - JVS314, 180mm x 120mm, 4 hole Base Plate -14g Bugle SS Screws

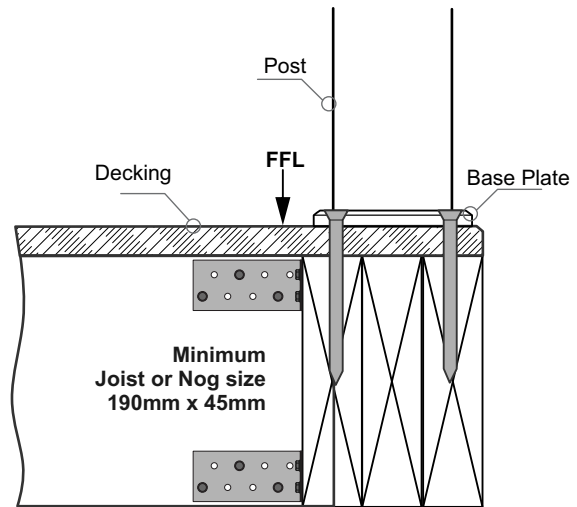

Important Installation notes:

- 1 - The Project Engineer must ensure the structure can support the appropriate loads**
- 2 - Screw engagement into joists 90mm. All Screws predrill 3.5mm holes**
- 4 - Bond all Screws with SIKA Supergrip30 to full depth**
- 5 - All Fixings must be Stainless steel**

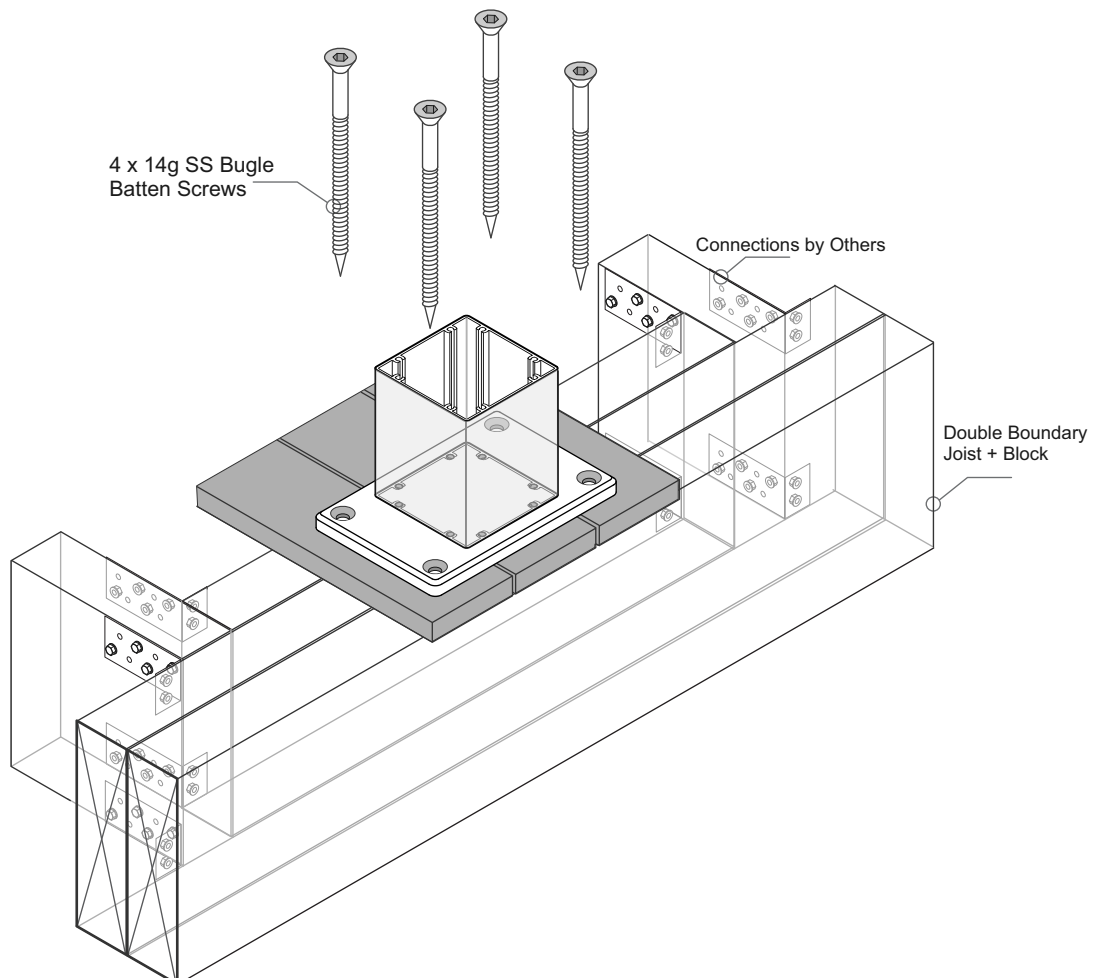

Typical TOP Fix to Concrete - JVS312, 180mm x 100mm, 2 hole Base Plate - M12 SS Studs

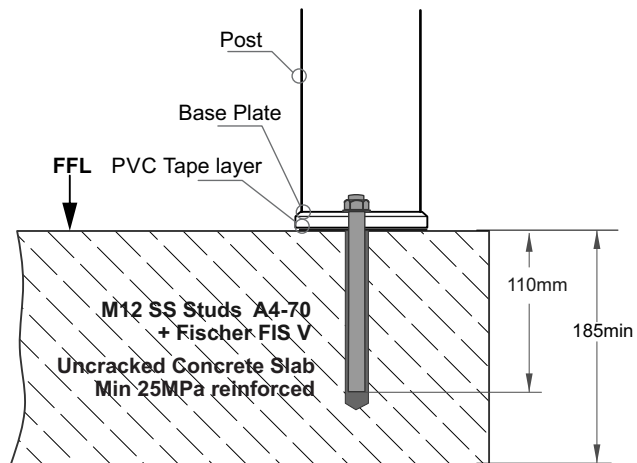

Stud projection
= 25mm + any packers



Installation details Fischer FIS V 300T

Thread diameter M12
 Drill hole diameter = 14 mm
 Drill hole depth = 120mm
 Anchorage depth = 110mm

Drilling method Hammer drilling
 Drill hole cleaning 4 times blowing,
 4 times brushing,
 4 times blowing

No borehole cleaning required in case of using a hollow drill bit, e.g. fischer FHD.

Important Installation Notes:

- 1 - The Project Engineer must ensure the structure can support the appropriate loads
- 2 - Substructure shown indicatively only
- 3 - Fixings must engage into the structural slab
- 4 - A PVC Tape layer must be installed between the Baseplate and Concrete
- 5 - Use Threadlok on Nuts
- 6 - All fixings must be Stainless Steel

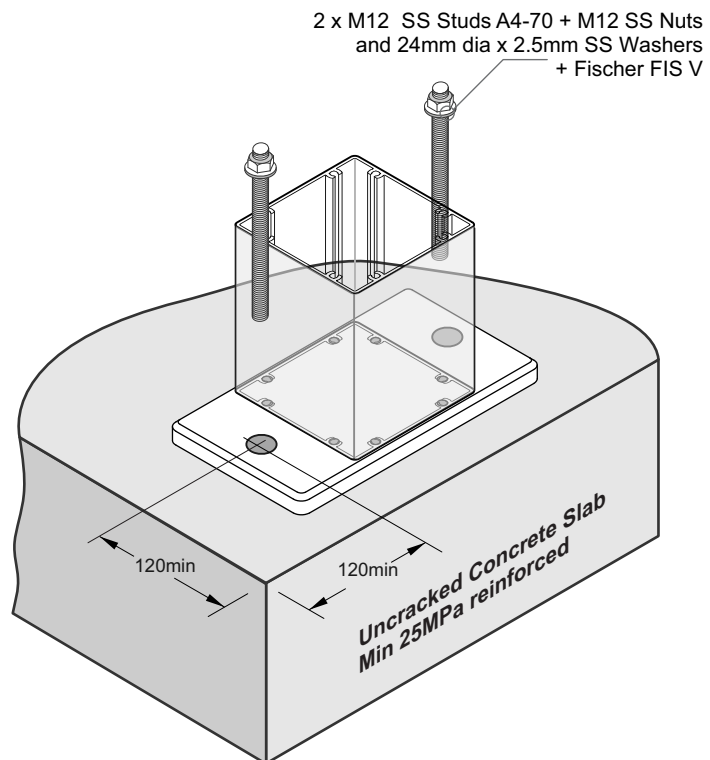

Juralco VelaSun® Outdoor Living System - Structural - Post attach to Concrete (All types)

Typical TOP Fix to Concrete - JVS312, 180mm x 100mm, 2 hole Base Plate - M12 SS Studs

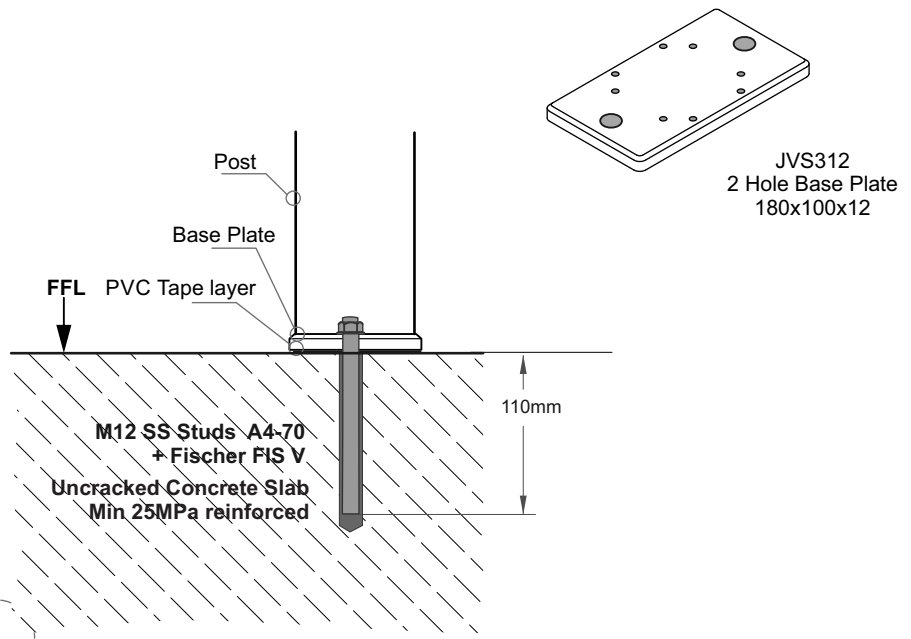

Installation details Fischer FIS V 300T

- Thread diameter M12
- Drill hole diameter = 14 mm
- Drill hole depth = 165 mm
- Anchorage depth = 155 mm

- Drilling method Hammer drilling
- Drill hole cleaning 4 times blowing,
 4 times brushing,
 4 times blowing

No borehole cleaning required in case of using a hollow drill bit, e.g. fischer FHD.

- Important Installation Notes:**
- 1 - The Project Engineer must ensure the structure can support the appropriate loads
 - 2 - Substructure shown indicatively only
 - 3 - Fixings must engage into the structural slab
 - 4 - A PVC Tape layer must be installed between the Baseplate and Concrete
 - 5 - Use Threadlok on Nuts
 - 6 - All fixings must be Stainless Steel

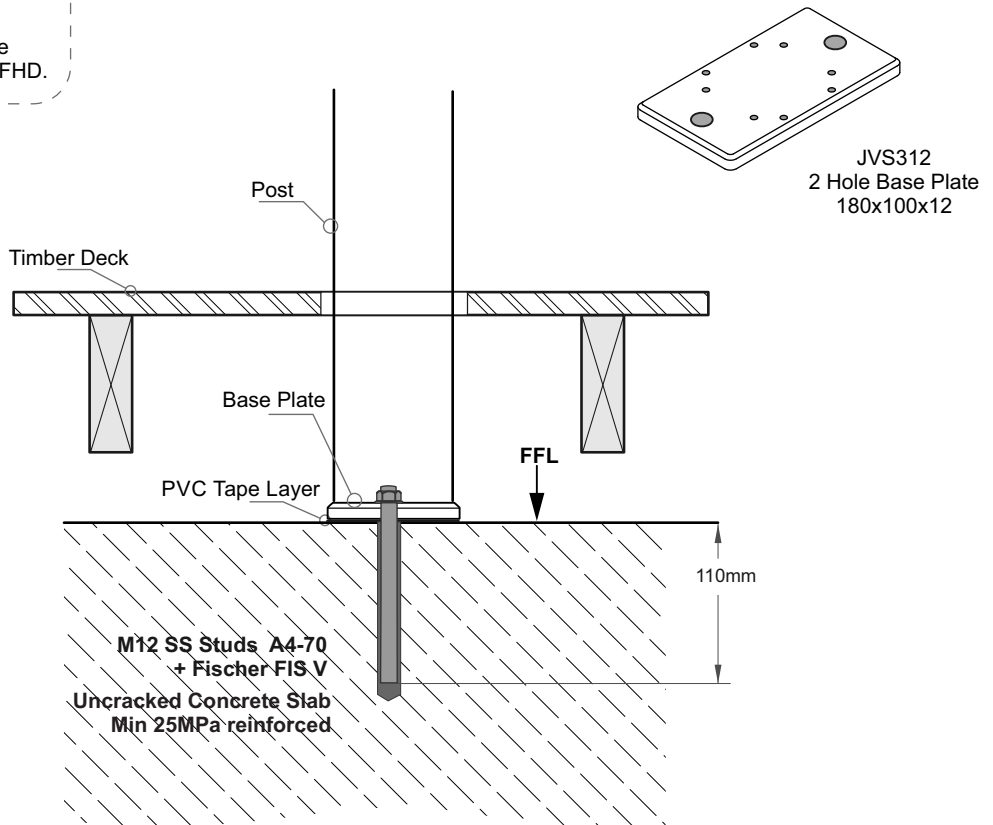

TECHNICAL DATA SHEET VELAGLAZE™ – 4mm

CROSS SECTION:

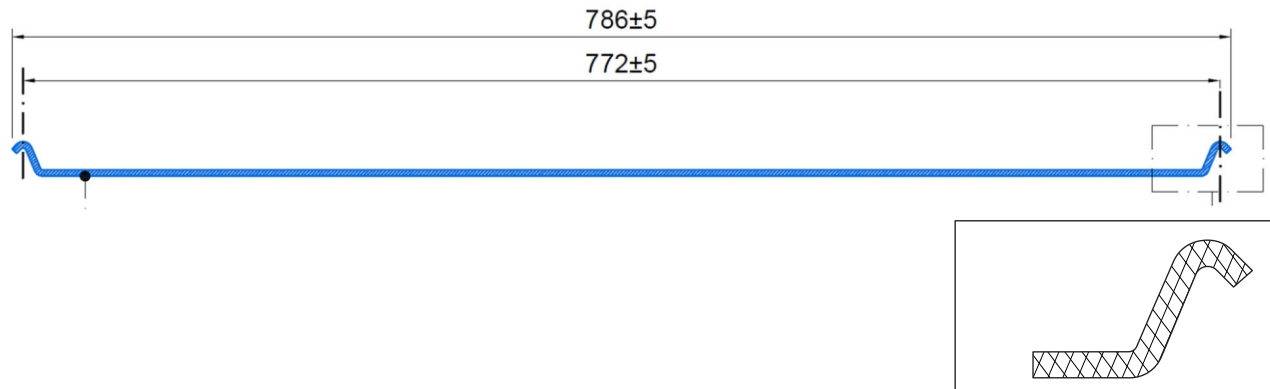

SPECIFICATIONS:

Sheet In Solid Polycarbonate With Profiled Sides. Useful Width Of 772±5 Mm, Thickness 4mm, Uv Protected On Both Sides.

The special sheet shape with side hooks allows for the junction through aluminium profiles to create a continuous system with a flat outer surface.

Fire Rated Euroclass B S1 D0.

TECHNICAL CHARACTERISTICS:

DATA	Unit	VELAGLAZE™
Thickness	mm	4
Useful width	mm	772±5
Height of package sheet+joining profile	mm	121
Sheet length	m	Manufactured to the exact length requested. For applications in lengths in excess of 4.8m please contact our Technical Dept.
Curvature radius	(R) m	1550mm
Colour		Grey.
UV protection		UV protection on both sides
Fire rating		B s1 d0
Temperature working range	°C	-40° / + 130°
Linear thermal expansion	mm/mm°C	6,7 x10 ⁻⁵
Resistance against chemicals / use & maintenance		See our literature for specifications
Thermal insulation	W/m²K	U= 5,33
Thermal Resistance	m²K/W	R = 0,02
Thermal conductivity	W/m°C	0,20
Light transmission	GREY %	0,53±2
Solar Heat Gain (SHGC)	GREY %	0,68±2
Shading coefficient (SC)	GREY %	0,78±2
Warranty 10 years – See our Warranty for terms & conditions		

PROPERTIES OF POLYCARBONATE

PROPERTIES		DATA	STANDARD
PHYSICAL PROPERTIES	Density	1200 Kg/m ³ (1,2 g/cm ³)	ISO 1183-1
	Water absorption 50% RH/23°C	0,15 %	ISO 62
	Water absorption (24h - 23°C) saturation	0,36 %	ISO 62
	Permeability to steam (23°C; 85% RH; 0,1mm)	15 g/(m ² 24h)	ISO 15106-1
	Refraction index 20°C	1,59	DIN 53491

PROPERTIES		DATA	STANDARD
MECHANICAL PROPERTIES	Tensile Strength To Yield	60 N/mm ² (60 Mpa)	ISO 527-2
	Tensile Strength To Break	70 N/mm ²	ISO 527-2
	Elastic Modulus	2300 N/mm ² (2300 Mpa)	ISO 527-2
	Shock Resistance	70 kJ/m ²	ISO 180/4A

PROPERTIES		DATA	STANDARD
PROPERTIES	Coefficient Of Linear Expansion	0,21 Wm°C	DIN 52612
	Linear thermal expansion	0,065 mm/mm°C	DIN 53752-A
	Temperature working range	-40 +130 °C	
	Softening point VICAT	148 -151 °C	ISO 306 (B/50)
	Specific heating	1,17 J/gk	



STORAGE - PROTECTING THE SHEETS FROM BAD WEATHER

To retain a high quality of the sheets, it is important that they be stored in places that are protected from damp and water. In fact, rain can cause the formation of condensate inside the cells of the sheet, which jeopardises its properties and reduce its usable lifetime. To prevent this problem, it is advisable to cover the sheets with waterproof protection or store them in a dry place when they are not used.

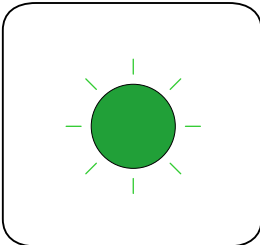

STORAGE - AVOID DIRECT EXPOSURE TO SUNLIGHT

If it becomes necessary to store the sheets outdoors, it is important to avoid their direct exposure to sunlight. Direct exposure to sunlight might cause an increase in temperature inside the packaging, thus leading to the formation of condensate or other forms of damp that would make removing the protective film more difficult.



HANDLING THE SHEETS

It is essential to be extremely cautious while handling sheets, so as to avoid that they become damaged by scratches or impacts that might jeopardise the material's characteristics and performance.



STORAGE OF THE SHEETS

Sheets can be stored stacked up to three pallets at the most. This means that it is possible to stack multiple layers of pallets, one on top of the other, so that the overall stack does not exceed three units



USE OF LIFTING EQUIPMENT

Transporting materials and goods into the warehouses requires the use of lifting equipment having forks that can be spaced out for a length of two metres, corresponding to the width of the pallet. It is of primary importance to pay attention during lifting manoeuvres.

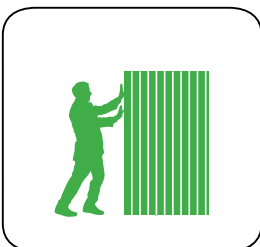

MANUAL HANDLING OF SHEETS

The manual handling of every single sheet must be done by at least two people who must keep them in the horizontal position. When lifting sheets, they must not rub against each other.



CUTTING

The sheets can be cut with a number of commonly used cutting tools, such as vertical or horizontal cutters, circular saws or hack sawing machines. It is important that the tools used have fine teeth so as to prevent the creation of irregular or jagged edges during the cutting process. Furthermore, the use of tools with fine teeth reduces the number of vibrations and heat generated while cutting, in this way increasing the quality of the cut material's surface.



SEALING OF THE SHEETS

Neutral silicone is a recommended choice when silicone has to be used for some reason. It is highly advisable to avoid use of acetic silicones.



PERFORATION

The sheets can be perforated successfully provided that the appropriate bit is used. It is recommended to choose a bit with the right characteristics in order to avoid damaging the sheet's surface. Screwing through is not recommended unless properly slotted to prevent thermal expansion.



HOW TO CLEAN POLYCARBONATE

Polycarbonate is a material that can be kept clean in a simple and effective way. If the surfaces to be cleaned are small, it will suffice to wash the sheet with a solution of lukewarm water and compatible detergent or mild soap. To avoid scratching the surfaces we recommend using a sponge or soft cloth. Then only quick drying is required afterwards.



WARNING

The sheets cannot be walked on either before or after laying.

Juralco VelaSun® Outdoor Living System - Polycarbonate Panel. User Instructions

INORGANIC SALTS	CHANGE
Sodium chloride 10%	Unchanged
Potassium nitrate 10%	Unchanged
Potassium dichromate 10%	Yellowing
Sodium sulphate 10%	Unchanged
Ammonium chloride	Unchanged
Sodium carbonate 10%	Unchanged
Sodium bicarbonate 10%	Surface cracking

Resistance to chemical agents

For installations where the product is planned to come into contact with aggressive chemical substances, it is recommended to check compatibility of the PC before use. The values shown in the table regard multiwall and solid sheets in polycarbonate at a test temperature of 23°C and with tension-free assembly.

INORGANIC ACIDS	CHANGE
35% Hydrochloric Acid	Surface cracking
10% Hydrochloric Acid	Unchanged
70% Sulphuric Acid	Yellowing
50% Sulphuric Acid	Unchanged
10% Nitric Acid	Yellowing
10% Chromic Acid	Unchanged

ALKALIS	CHANGE
1% Sodium Hydrate	Unchanged
10% Sodium Hydrate	Slight opacification
10% Ammonium Hydrate	Disintegration
10% Calcium Hydrate	Unchanged

ALCOHOLS	CHANGE
Methyl Alcohol	Surface cracking
10% Ethyl Alcohol	Unchanged
n-Butyl Alcohol	Unchanged
Ethylene Glycol	Unchanged

MISCELLANEOUS	CHANGE
Benzol	Dissolution
Toluene	Dissolution
Industrial petrol	Opacification and cracking
Kerosene	Unchanged
Nafta Diesel	Unchanged
N Heptane	Unchanged
Cyclohexane	Unchanged
Methyl isobutyl ketone	Unchanged
Butyl acetate	Softening
Methyl methacrylate	Softening
Acrylonitrile	Dissolution

LUBRICATING OILS	CHANGE
Machine oil	Unchanged
Paraffin oil	Unchanged
Silicone oil	Unchanged

PLASTICIZERS	CHANGE
Tricresyl phosphate	Not resistant
Diocetyl adipate	Not resistant
Bis(2-ethylhexyl) phthalate	Not resistant
Butyl Stearate	Not resistant

ORGANIC ACIDS	CHANGE
70% Acetic Acid	Unchanged
10% Acetic Acid	Partially resistant
30% Formic Acid	Partially resistant
35% Lactic Acid	Unchanged
10% Oxalic Acid	Unchanged
10% Benzoic Acid	Not resistant
100% Oleic Acid	Unchanged

MISCELLANEOUS	CHANGE
Vinyl acetate	Softening
Ethyl ether	Not resistant
Diethylenetriamine	Dissolution
Ethylenediamine	Dissolution
Triethanolamine	Surface cracking
5% Phenol	Opacification
Cresol	Unchanged
Formalin	Unchanged
10% Hydrogen Peroxide	Yellowing
Synthetic saliva pH 9	Unchanged
Synthetic saliva pH 5	Unchanged



Australian Wool Testing Authority Ltd - trading as AWTA Product Testing
A.B.N 43 006 014 106
1st Floor, 191 Racecourse Road, Flemington, Victoria 3031

AS/NZS 1530.3-1999

Methods for Fire Tests on Building Materials, Components and Structures

Part 3: Simultaneous Determination of Ignitability, Flame Propagation, Heat Release and Smoke Release

Test Number :17-006206 **Issue Date:**9/11/2017 **Print Date:**9/11/2017

Sample Description Clients Ref : "Solid Polycarbonate"

Clear polycarbonate sheet. Colour - Clear

End Use :Roofing/Cladding/Industrial Protections

Nominal Composition :Polycarbonate

Nominal Mass per Unit Area/Density 7.2kg.m

Thickness 6mm

2

Test Report:

Ignition is initiated by a pilot flame that is held near, but does not touch the specimen .

A material that does not ignite during the standard test may ignite if contacted with a pilot flame during the test.

The specimens melted and flowed away from the area of maximum heat during the test.

Due to this phenomena it should be recognized that this test result may not be a true indication of the product's fire hazard properties.

Each test specimen was sandwiched between two layers of galvanised welded square mesh made from wire of nominal diameter 0.8mm and nominal spacing 12mm in both directions and the assembly clamped along all sides.

The specimens were mounted to simulate use in an unsupported or free hanging mode.

The results may be significantly different when mounted to simulate a wall cladding or upholstery application.

These results only apply to the specimen mounted, as described in this report.

The result of this fire test may be used to directly assess fire hazard, but it should be recognised that a single test method will not provide a full assessment of fire hazard under all fire conditions.

Juralco VelaSun® Outdoor Living System - Polycarbonate Panel Length Calculations

Polycarbonate Panels

All Preformed Standing Seams, both long edges
 JVS/P4824 4mm Grey Polycarbonate Panel 800 x 2400mm
 JVS/P4828 4mm Grey Polycarbonate Panel 800 x 2800mm
 JVS/P4832 4mm Grey Polycarbonate Panel 800 x 3200mm
 JVS/P4840 4mm Grey Polycarbonate Panel 800 x 4000mm
 JVS/P4848 4mm Grey Polycarbonate Panel 800 x 4800mm

No Panels	Width, mm
3	2477
4	3277
5	4077
6	4877
7	5677
8	6477
9	7277
10	8077
11	8877
12	9677
13	10477
14	11277
15	12077

15 x Polycarbonate Panels
 = 4 x Posts @ 3.6m max spacing
 = 10.8m
 + 2 x Overhangs @ 0.6m = 1.2m
 = Total length 12m max

Polycarbonate Pergola, showing 6 x Panels

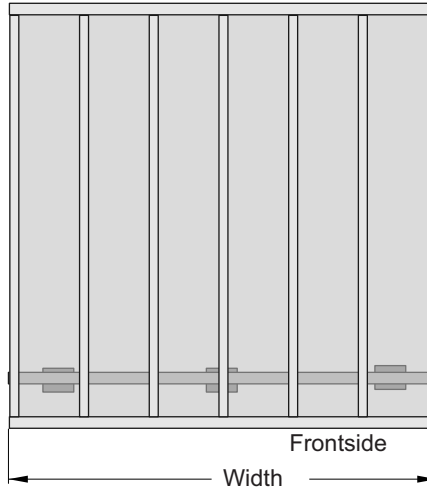

VELASUN	Infill Panel Type - Order Form	VS #
Customer	Contact	
Order No	Date	
WO Juralco	SO Juralco	\$ Juralco
Select/Enter Dimensions below. Enter details/selections into all boxes. Then scan and send to sales@juralco.co.nz		

1 Select Infill Panel Velasun Type

Polycarbonate Pergola

No of Posts

No of Panels

Side A	Wall	JOR710	JVS309

Post Centre Spacing, Dimensions

LH End Overhang to Post 1. Enter	<input type="text"/>
Spacing Post 1 to Post 2. Enter	<input type="text"/>
Spacing Post 2 to Post 3. Enter	<input type="text"/>
Spacing Post 3 to Post 4. Enter	<input type="text"/>
RH End Overhang from Post 4. Enter	<input type="text"/>

These Totals should = OA Width

For Polycarbonate only.
OA Width = No Panelsx800+77mm.
See Previous page showing Max no Panels

For Polycarbonate only.
Must choose a Panel Length

2400	<input type="text"/>	4000	<input type="text"/>
2800	<input type="text"/>	4800	<input type="text"/>
3200	<input type="text"/>		<input type="text"/>

Glass Pergola

No of Posts

Rafter Spacing

Purlin Setback

Side A	Wall	JOR710	JVS309

Check Wind Zone, max Sizes; refer to Manual

2 For the selected Velasun Type, Enter details, mm

Glass only	OA Depth <input type="text"/>	Glass only	OA Width <input type="text"/>	
Posts max Height - 2.9m	Post height <input type="text"/>	For Polycarbonate only. OA Width = No Panelsx800+77mm. See Previous page showing Max no Panels		

Choose Baseplate

JVS314 4 Hole Base Plate	<input type="text"/>
JVS312 2 Hole Base Plate	<input type="text"/>

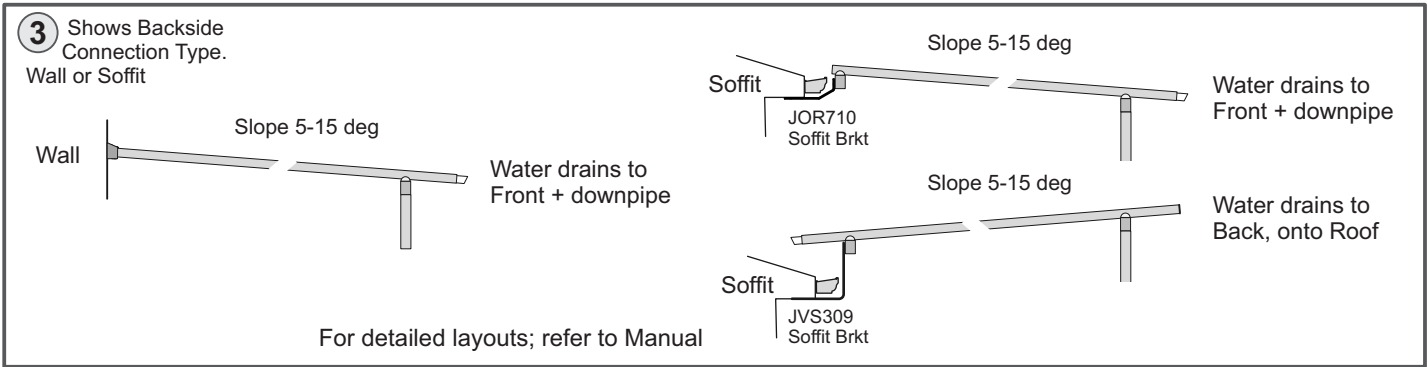

4 Select Powder Coat Type and Colour

Duralloy Plus	<input type="text"/>	Specify PC Colour and Code
Duratec	<input type="text"/>	

5 Notes:

VELASUN	Roofless System - Two Wall Order Form	VS #
Customer	Contact	
Order No	Date	
WO Juralco	SO Juralco	\$ Juralco
Select/Enter Dimensions below. Enter details/selections into all boxes. Then scan and send to sales@juralco.co.nz		

1 REQUIRED MARKUPS:
 Select Roofless Velasun Type
 1. Select orientation of rafters.
 2. Draw in all sides mounted to a structure (Wall or Soffit Fix).

Side A Length

Side B Length

Side A Length

Side B Length

2 For the selected Velasun Type, Enter details, mm

Approximate rafter spacing	<input style="width: 100%;" type="text"/>	Machined with equal gaps	
Post height	<input style="width: 100%;" type="text"/>	Posts max Height - 2.9m	

Choose Baseplate	<table border="1" style="width: 100%; border-collapse: collapse;"> <tr> <td style="width: 50%;">JVS314 4 Hole Base Plate</td> <td style="width: 50%;"><input style="width: 100%;" type="text"/></td> </tr> <tr> <td>JVS312 2 Hole Base Plate</td> <td><input style="width: 100%;" type="text"/></td> </tr> </table>	JVS314 4 Hole Base Plate	<input style="width: 100%;" type="text"/>	JVS312 2 Hole Base Plate	<input style="width: 100%;" type="text"/>
JVS314 4 Hole Base Plate	<input style="width: 100%;" type="text"/>				
JVS312 2 Hole Base Plate	<input style="width: 100%;" type="text"/>				

3 Shows Backside Connection Type. Wall or Soffit

Horizontal

Horizontal

JOR 710 Soffit Brkt

Horizontal

JVS309 Soffit Brkt

For detailed layouts; refer to Manual

4 Select Powder Coat Type and Colour

Duralloy Plus	<input style="width: 100%;" type="text"/>	Specify PC Colour and Code
Duratec	<input style="width: 100%;" type="text"/>	

5 Notes:

VELASUN	Roofless System - One Wall Order Form	VS #
Customer	Contact	
Order No	Date	
WO Juralco	SO Juralco	\$ Juralco
Select/Enter Dimensions below. Enter details/selections into all boxes. Then scan and send to sales@juralco.co.nz		

1 REQUIRED MARKUPS:
 1. Select orientation of rafters.
 2. Draw in all sides mounted to a structure (Wall or Soffit Fix).

Select Roofless Velasun Type

Side A Length

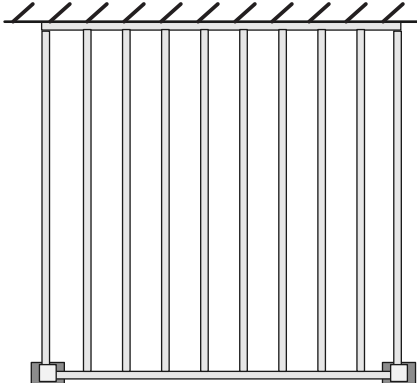

Side B Length

Side A Length

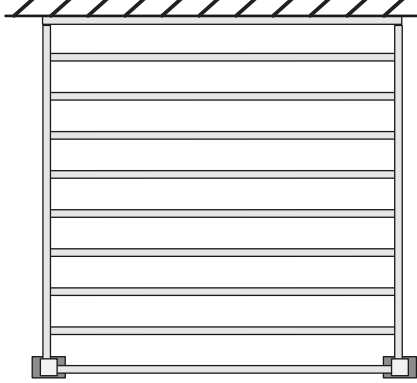

Side B Length

2 For the selected Velasun Type, Enter details, mm

Approximate rafter spacing	<input style="width: 100%;" type="text"/>	Machined with equal gaps	
Post height	<input style="width: 100%;" type="text"/>	Posts max Height - 2.9m	

Choose Baseplate	<table border="1" style="width:100%; border-collapse: collapse;"> <tr> <td style="width:80%;">JVS314 4 Hole Base Plate</td> <td style="width:20%;"><input style="width: 100%;" type="text"/></td> </tr> <tr> <td>JVS312 2 Hole Base Plate</td> <td><input style="width: 100%;" type="text"/></td> </tr> </table>	JVS314 4 Hole Base Plate	<input style="width: 100%;" type="text"/>	JVS312 2 Hole Base Plate	<input style="width: 100%;" type="text"/>
JVS314 4 Hole Base Plate	<input style="width: 100%;" type="text"/>				
JVS312 2 Hole Base Plate	<input style="width: 100%;" type="text"/>				

3 Shows Backside Connection Type. Wall or Soffit

Horizontal

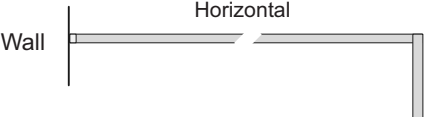

Horizontal



JOR 710 Soffit Brkt

Horizontal



JVS309 Soffit Brkt

For detailed layouts; refer to Manual

4 Select Powder Coat Type and Colour

Duralloy Plus	<input style="width: 100%;" type="text"/>	Specify PC Colour and Code
Duratec	<input style="width: 100%;" type="text"/>	

5 Notes:

Juralco VelaSun® Outdoor Living System - Powder Coating Care and Maintenance

Powder Coating Installation Care

Warning re use of solvents:

- In some cases strong solvents are recommended for thinning various types of paints and also for cleaning up mastics and sealants.
- These can be harmful to the extended life of the powder coated surface, and must not be used for cleaning purposes.
- It is important to note that the damage will not be visible immediately and may take up to 12 months to develop.

If paint splashes or sealants and mastics need to be removed then the following may be safely used:
Methylated Spirits, Ethyl Alcohol, Isopropanol or preferably a mild detergent in warm water.

Joinery Protection during Installation:

All the activity on a construction site means that your powder coated items may get knocked or scratched, splattered with mortar, plaster, textured coating or paint during the later stages of construction.

Please ensure that all powder coated articles are masked or covered at this time. It is far easier to prevent accidents than to try and correct them. Should your joinery receive mortar or paint splashes see that these are removed before cure and follow the instructions contained in this brochure.

"IMPORTANT ALL TRADES"
This valuable aluminium joinery will suffer permanent damage from: plaster, mortar and paint splashes - Protect if splashes occur - Immediately wash down joinery with water or meths - Do not allow splashes to harden! ~ Do not use solvents! - Do not remove this label until final clean completed.

Typical sticker used to warn other trades of the need to protect and mask off powder coated joinery (applies to anodised joinery also)

Powder Coating Maintenance

External - Maintenance Program:

To extend the life of external powder coated articles and to comply with warranty requirements for powder coated aluminium joinery, a simple, regular maintenance program must be implemented.

The effects of ultra violet light, atmospheric pollution, dirt, grime and airborne salt deposits will all accumulate over time and must be removed or surface staining and weathering will occur, leading to an unsightly appearance.

For external coatings, cleaning should take place every six months. In areas where pollutants are more prevalent, such as beachfront houses and industrial or geothermal areas, then a cleaning program should be carried out on a more frequent basis ie. every one to three months.

Fences or Balustrades in close proximity to swimming pools must be washed down every six months, to clean off chlorine and salt deposits.

Cleaning your powder coating:

1. Carefully remove any loose surface deposits with a wet sponge.
2. Use a soft brush (non abrasive) and a mild household detergent (do not use solvents) in warm water, remove dust, salt and other deposits.
3. Rinse off with clean fresh water.

Restoring weathered or scratched surfaces:

Repair of Scuffed or Scratched surfaces
Dulux Spray Cans are available in all colour card colours.

Repair of Small Scratches or Chips.
Dulux Dabsticks are ideally suited for the repair of small scratches.
Dabsticks may not be available in all colour card colours.

Repair of Weathered areas .
Dulux Gloss Up is a light to medium cutting cream ideally suited for gloss restoration and has been specifically designed for this purpose.
Gloss Up contains no waxes or silicone and is a one step system.



Contact Dulux Powder Coatings , ph 0064 9 441 8244

Polycarbonate panels - Care and Maintenance

All the activity on a construction site means that your polycarbonate panels may get knocked or scratched, splattered with mortar, plaster, textured coating or paint during the later stages of construction. The Panels need protection as they scratch very easily.

Wash gently with a hose, then finish off with warm soapy water and a soft bristle brush or a cloth.
Finish with a final Hose down.
Recommended to clean every 12 mths as a minimum.