



# **JURALCO ROLLINE™ FRAMELESS GLASS SLIDING DOOR SYSTEM**

ISSUE 6-24 v1

## Juralco Rolline™ Frameless Glass Sliding Door System

Juralco Aluminium Building Products Ltd has for more than 25 years been at the forefront of designing and fabricating specialist Aluminium based Residential and Commercial products.

All for New Zealand joinery and building methods.

Our comprehensive product range includes Security and Insect screens, Balustrades and Gates, Shade Structures and Awnings, Shower screens and Wardrobe systems. Distribution is through a national network of Franchised specialist Fabricators.

The Juralco Rolline™ Frameless Glass Sliding Door System is fitted with 10 or 12mm Toughened Glass up to 3.0m wide and 2.7m high but maximum Glass weight 200kg all depending on Wind Zones.

External non waterproof applications are available for Low wind zones.

The system is especially suitable for high end internal Residential and Commercial applications.

### Index

Type	Pages	Description	<a href="#">Use the Bookmarks</a>  <a href="#">List to jump to selected pages</a>
Specifications	3	Juralco and Powder Coating Specifications	
Setouts - Bottom Roller	4	Shows all Setouts for Single and Multiple Tracks. Also Glass Panel Size/Glass Thickness/Wind zone	
Extrusions	5 - 6	Shows Rolline Extrusions and Components	
Door Setout	7	Shows Rolline Single Door	
Glass Panel Order Form	8	Shows Rolline Door Glass Panel Order Form	
Handles	9	Shows Rolline Door Handle	
Installation Tips	10	Installation recommendations	
Glass, Powder coat care	11	Instructions for the care of Glass and Powder coated surfaces	

# Juralco Rolline™ Frameless Glass Sliding Door System

## Juralco Aluminium Building Products Ltd (JABP) Specifications for Juralco Rolline™ Frameless Glass Sliding Door System

### 1. Scope

- This specification details the documents the Juralco Rolline™ Frameless Glass Sliding Door System refers to, in relation to the New Zealand Building Code, the manufacturer's documents, products used in the system and requirements in relation to fixing and surface finishing.

### 2. NZBC Compliance

- The Juralco Rolline™ Frameless Glass Sliding Door System has been reviewed by Lautrec Technology Group Ltd to demonstrate compliance with the structural requirements of the New Zealand Building Code, B1 Structure, B2 Durability (15 yrs), F2 Hazardous material and in particular:  
AS/NZS 1170.0:2002 Structural Design Actions-Part 0: General Principals  
AS/NZS 1664.1:1997 Aluminium structures limit state design  
NZS4223.3:2016 Glazing in buildings - Human impact and safety requirements  
NZS4223.4:2008 Glazing in buildings  
Note: The Juralco Rolline™ Frameless Glass Sliding Door System is NOT a barrier for Safeguard from Falling (F4)  
Note: This Door CANNOT be considered as an access route as detailed in Building Code Clause D1 Access Route

### 3. Manufacturer's Documents

- The Juralco Rolline™ Frameless Glass Sliding Door System manual details all extrusions and components used for the fabrication and installation/fixing of the system
- A Producer Statement 1(Design) is available.  
Copies of the above documents are available from:  
Juralco Aluminium Building Products Ltd  
48 Bruce McLaren Rd, Henderson, Auckland  
Phone 09 478 8018 Fax 09 478 7883 Email specify@juralco.co.nz
- Any deviation from the standard fabrication or installation/fixing must be accompanied by a site specific PS1 with site specific calculations and drawings

### 4. Products

- Only extrusions, components and hardware supplied by or specified by JABP may be used in the Juralco Rolline™ Frameless Glass Sliding Door System
- Aluminium extrusions, components and hardware – unless specified are manufactured to 6060 T5 specifications
- Stainless Steel components, hardware, fixings – all components to 316 grade

### 5. Surface Finishing

- Juralco Aluminium Building Products Ltd is a Dulux Registered Applicator site, registration number 2101.  
JABP uses only Dulux branded powder coating materials
- Dulux Duralloy® powder coating systems are suitable for properties greater than 100m from high tide level  
AAMA 2603 performance. Residential buildings, 3 levels max. Warranty 10 yrs
- Dulux Duralloy Plus® powder coating systems are suitable for properties greater than 10m from high tide level.  
AAMA 2603 performance. Residential and Light commercial buildings, 3 levels max Warranty 15 yrs
- Dulux Duratec® powder coating systems are suitable for properties greater than 10m from high tide level  
AAMA2603 and 2604 performance. All Residential and Commercial buildings. Warranty 25 yrs

### 6. Installation and Fixing

- The Juralco Rolline™ Frameless Glass Sliding Door System must only be installed in accordance with the Juralco Rolline™ Frameless Glass Sliding Door System manual
- Any deviation from that specified in the Juralco Rolline™ Frameless Glass Sliding Door System manual must only be in accordance with the site specific PS1 with site specific calculations and drawings listing the non standard details
- The Juralco Rolline™ Frameless Glass Sliding Door System must only be fabricated/installed by a Juralco approved fabricator
- Upon completion of the installation the fabricator must supply the owner with a PS3 (Construction)

#### Important information - Powder Coating systems.

**Powdercoat Systems** The new standard Dulux powder coating system used by Juralco is Duralloy Plus®. Also Duralloy® and Duratec®. All as per specs above. Juralco Powder coated prices are for Duralloy Plus® and Duralloy® (same pricing). Duratec® prices on application.

**Attachment to structures** A PVC Tape or similar material spacer must be used to separate powder coated aluminium items from all concrete and steel structures. Failure to do so can lead to the chemicals in the structure affecting the powder coating, leading to corrosion.

**Swimming Pools** The chlorinated water in swimming pools can cause the deterioration of powder coated surfaces, leading to corrosion of the underlying surface. It is recommended that Powder coated surfaces be 1200mm min from a pool.

**Care** The Dulux powder coating warranty period is conditional upon the surface being maintained in accordance with the Dulux 'Care and Maintenance Instructions'. Download from Dulux or refer to the back page of this manual.

# Juralco Rolline™ Frameless Glass Sliding Door System

**Application.** Most applications are Internal for Residential or Commercial Buildings.  
Doors from 10mm or 12mm Toughened Safety Glass

- Notes (per panel)
- Max Height 2.7m
  - Max Width dimension 3.0m
  - Min Width 0.8m
  - Glass wt max 200kg
  - Max Wind pressure 0.6kPa

- Notes:
- 10mm Toughened Glass 25kg/m<sup>2</sup>
  - 12mm Toughened Glass 30kg/m<sup>2</sup>

## Some Typical Layouts

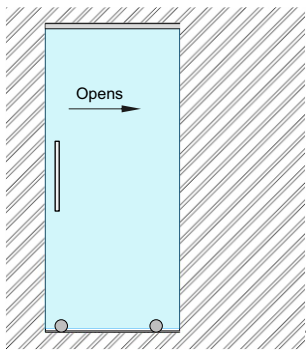

Single Door, Single Track

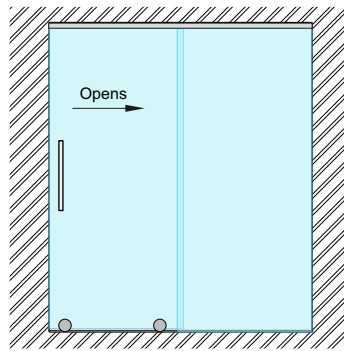

Single Door, Single Track  
1 x Sliding Door, 1 x Fixed Panel

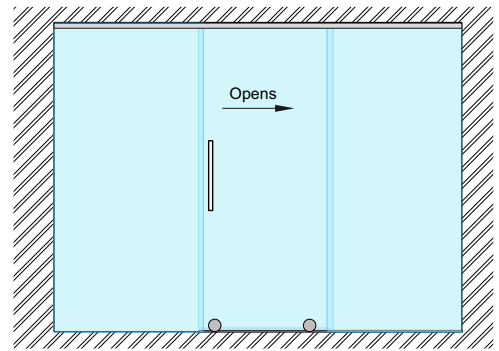

Single Door, Single Track  
1 x Sliding Door, 2 x Fixed Panels

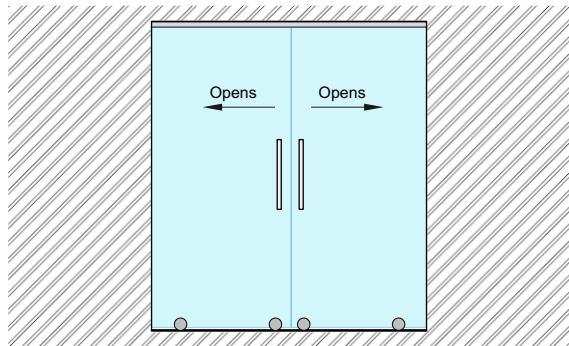

Double Doors, Single Track  
2 x Sliding Doors

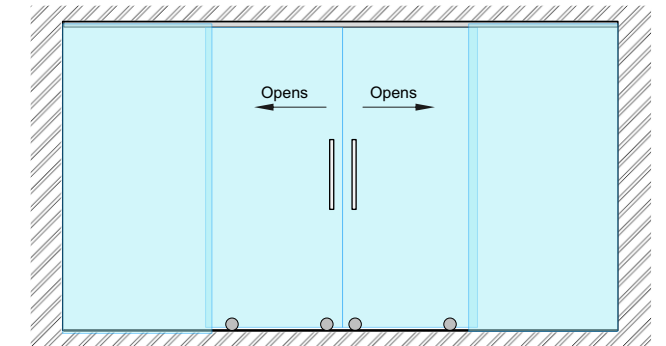

Double Doors, Single Track  
2 x Sliding Doors, 2 x Fixed Panels

**Juralco Rolline™ Frameless Glass Sliding Door System  
Extrusions, Components. Wheel Construction**

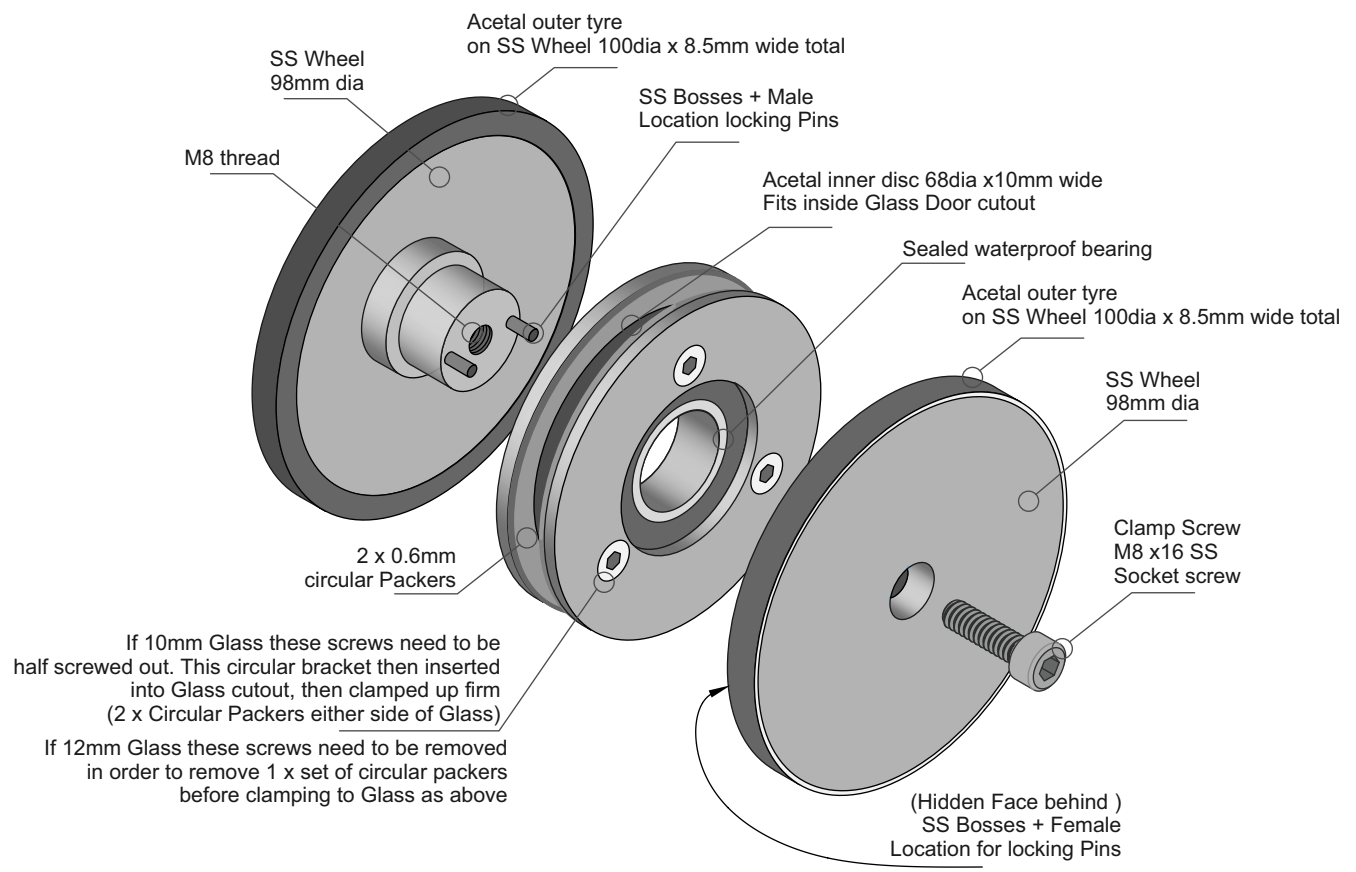
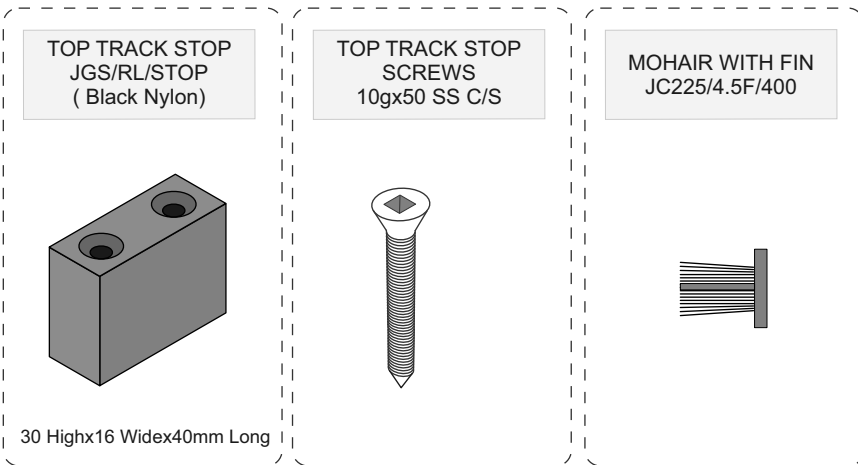
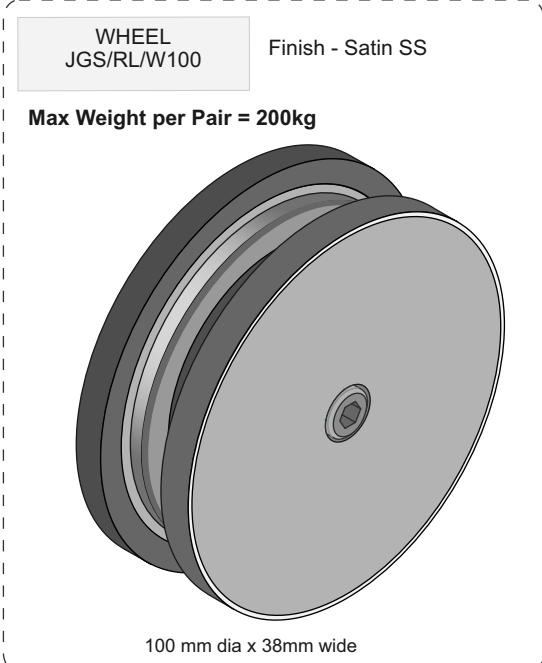
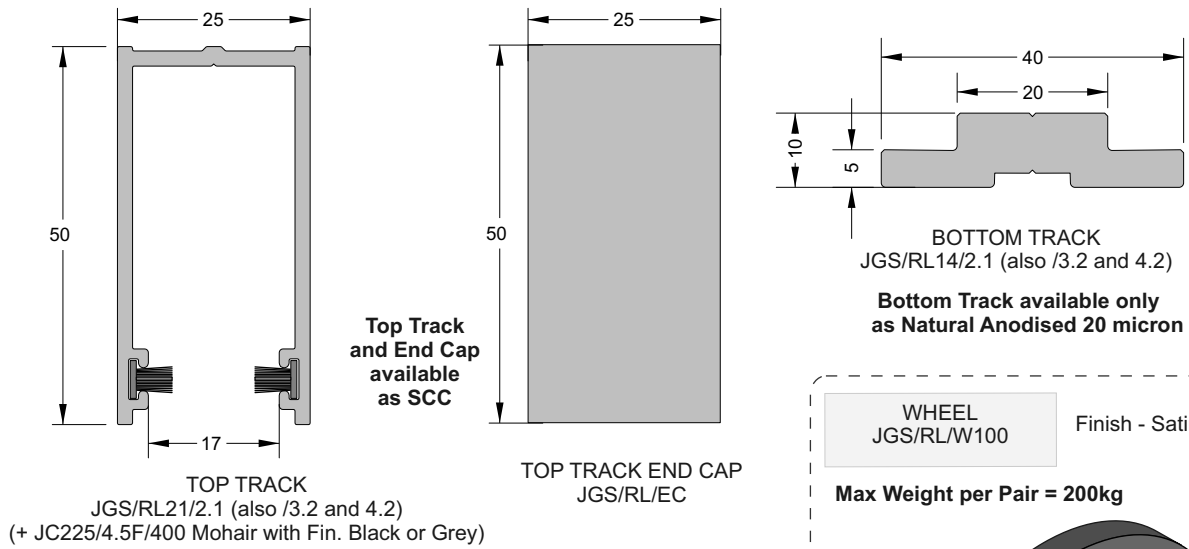

Juralco Rolline™ Frameless Glass Sliding Door System

Door Seals

**DS SERIES**  
**Door Seals + Components**

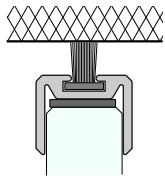

**G/DS10/3**

Aluminium extrusion, with Mohair  
+ Double sided tape.  
For 10mm Glass. NAT or SCC

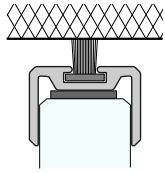
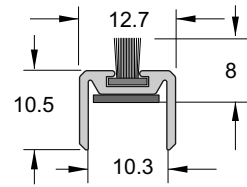

**G/DS12/3**

Aluminium extrusion, with Mohair  
+ Double sided tape.  
For 12mm Glass. NAT or SCC

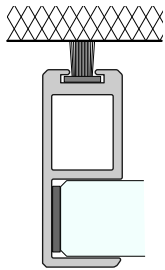
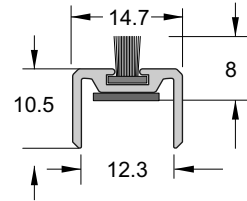

**G/DS1090/3**

Aluminium extrusion, with Mohair  
+ Double sided tape.  
For 10mm Glass. NAT or SCC

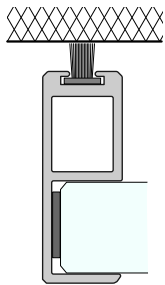
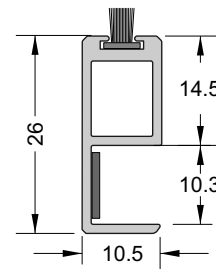

**G/DS1290/3**

Aluminium extrusion, with Mohair  
+ Double sided tape.  
For 12mm Glass. NAT or SCC

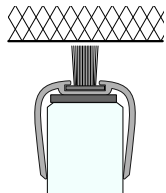
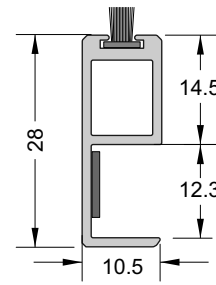

**G/DSP10/3**

Clear Polycarbonate extrusion, with Mohair  
+ Double sided tape.  
For 10mm Glass

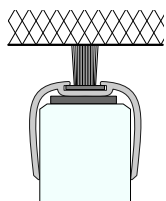
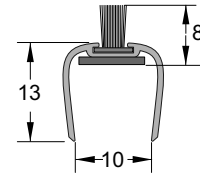

**G/DSP12/3**

Clear Polycarbonate extrusion, with Mohair  
+ Double sided tape.  
For 12mm Glass

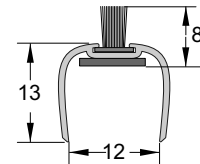

**Juralco Rolline™ Frameless Glass Sliding Door System  
Wheel Construction, Installed Heights, Widths**

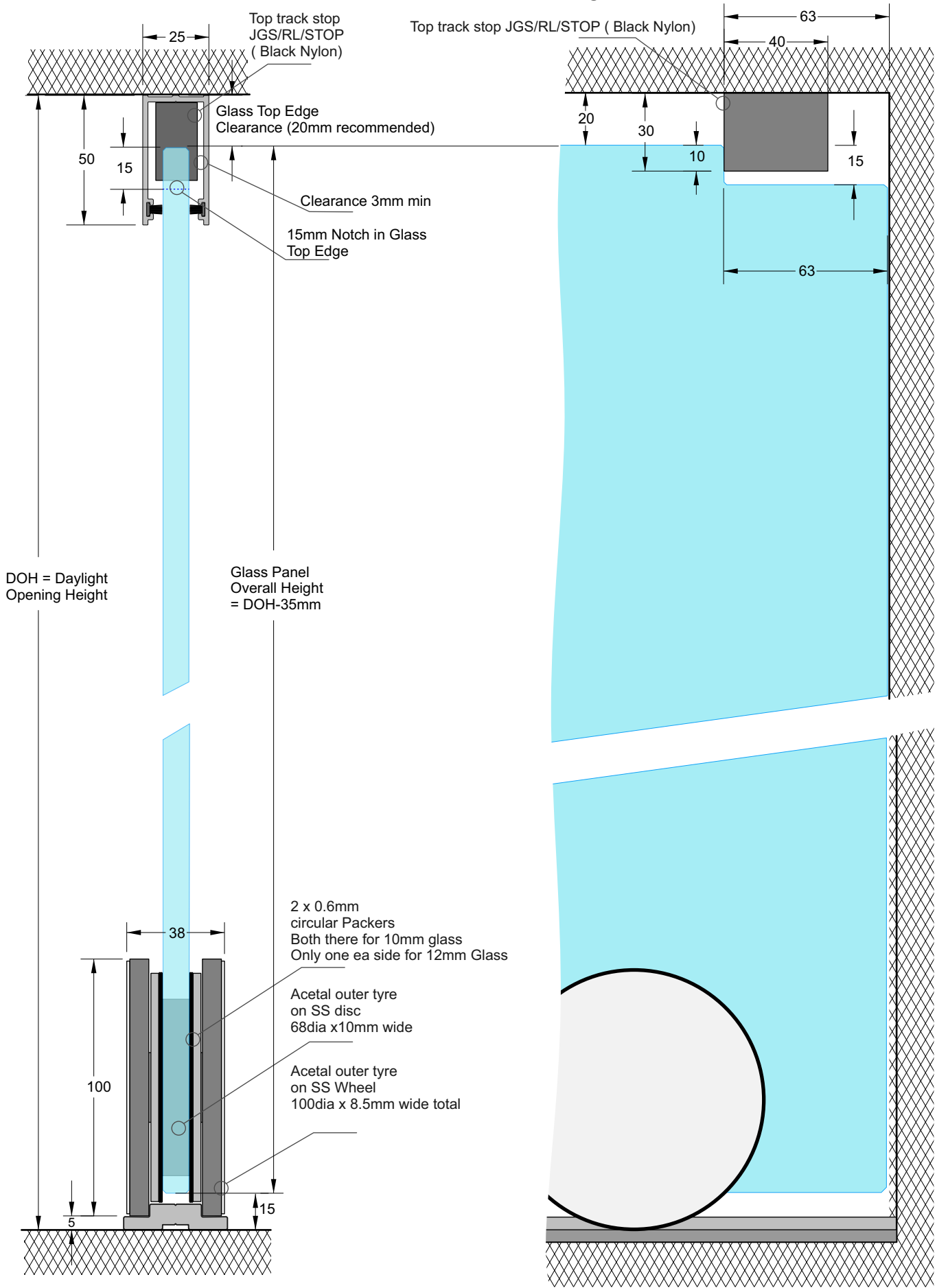

# Juralco Rolline™ Sliding Glass Door - Order Form

Customer	Contact	Date
Order No	Deliver to Address	
Notes		
Enter Dimensions on PLAN. Then scan and send to <a href="#">Glass manufacturer</a>		No identical

Tick for Glass Panels. 10mm  or 12mm  Toughened Glass. No sharp corners

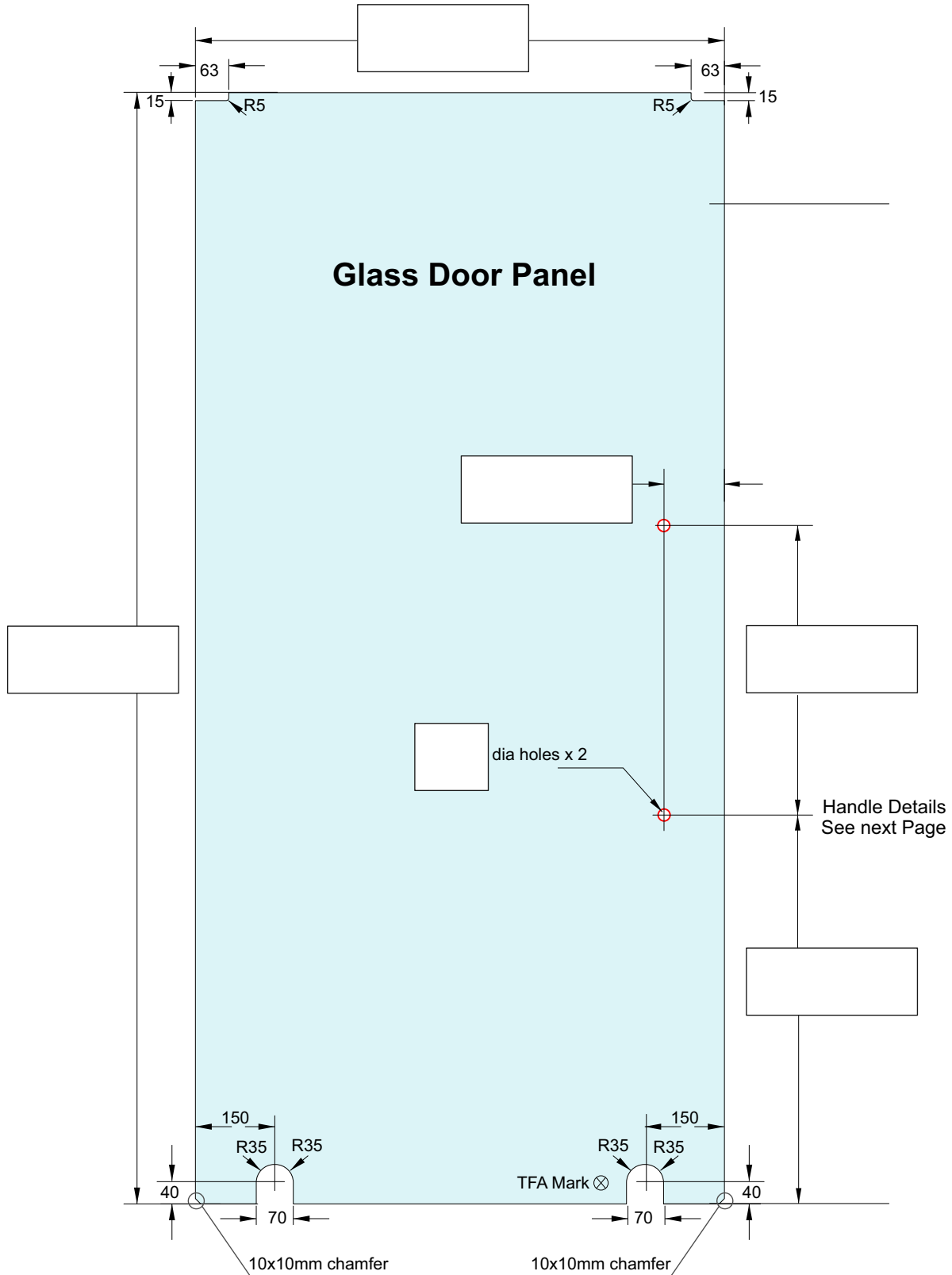



**Juralco Rolline™ Frameless Glass Sliding Door System**  
**Handles 10mm or 12mm Toughened Glass**

**PH SERIES**  
**Commercial Handles**

Finishes to choose from,  
SSS - Satin Stainless Steel  
PSS - Polished Stainless Steel  
SCC - Powder coat. Dulux Duralloy range

Refer to the Price List for a complete range of Handles

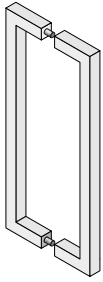

Square D Pull Handle. 25mmsq  
Hole Centres 450, 600 and 900 mm  
304 Stainless Steel

Finish Options	
Part No G/PHSQD/450	SSS
Part No G/PHSQD/600	SSS,PSS,SCC
Part No G/PHSQD/900	SSS,SCC

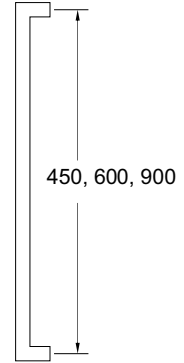
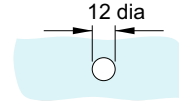

# Juralco Rolline™ Frameless Glass Sliding Door System

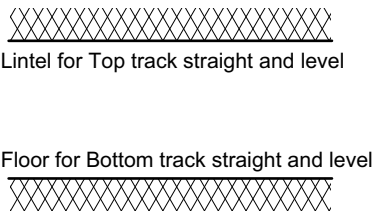
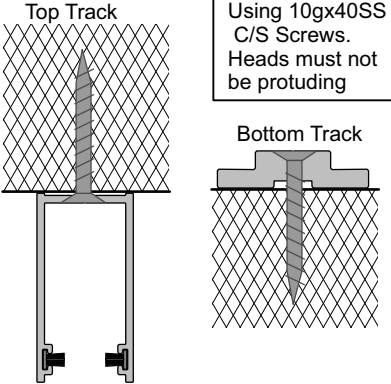
Product	Installation/Fitting Instructions
<p><b>Track Preparation</b></p>  <p>Lintel for Top track straight and level</p> <p>Floor for Bottom track straight and level</p>	<ol style="list-style-type: none"> <li>1 - Check lintel to ensure fixing for the Top channel is level.</li> <li>2 - Check Flooring to ensure the floor for the Floor track is level.</li> <li>3 - Packers can be used to level the overall track length. The packers are NOT included in this kit. Packer width should not exceed the width of the track (25mm Top, 40mm Bottom).</li> </ol> <div style="border: 1px solid black; padding: 5px; margin-top: 10px;"> <p>Notes:</p> <ol style="list-style-type: none"> <li>1 - The structure is to be designed by the Site Engineer, to support the appropriate loads.</li> </ol> </div>
<p><b>Installation of the Tracks to the Supporting Structure</b></p>  <p>Top Track</p> <p>Using 10gx40SS C/S Screws. Heads must not be protruding</p> <p>Bottom Track</p>	<ol style="list-style-type: none"> <li>1 - Fix the <u>Top channel track</u> using 10g x 40mm SS countersunk screws at 100mm centres to suit the structure you are fixing to. Ensure the screw heads are flush with the channel so that the glass doesn't catch them.</li> <li>2 - Fix the <u>Bottom channel track</u> using 10g x 40mm SS countersunk screws at 200mm centres to suit the structure you are fixing to. Ensure the screw heads are flush with the track so the glass or roller wheels don't catch them.</li> <li>3 - Slide track mounted bump stops and fix the bump stops at their nominated distances from each end of the track.</li> </ol> <div style="border: 1px solid black; padding: 5px; margin-top: 10px;"> <p>Notes re Screw Fixing:</p> <ol style="list-style-type: none"> <li>1 - Timber Fixings. 10g CSK SS Wood screws. 35mm min engagement into SG8 timber.</li> <li>2 - Concrete Fixings. 10g CSK SS Screws 30mm min engagement into Hilti HUD-1 Plastic Wall Plug.</li> </ol> </div>

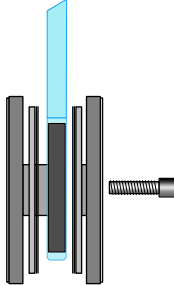
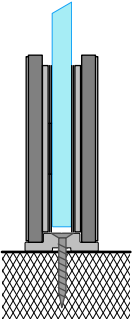
Product	Installation/Fitting Instructions
<p><b>Wheels</b></p> 	<ol style="list-style-type: none"> <li>1 - Assemble the 100mm running wheels on to the glass panel.</li> </ol>
<p><b>Final Adjustment</b></p> 	<ol style="list-style-type: none"> <li>1 - Lubricate the inside track &amp; all moving parts of the carriages with silicone spray.</li> <li>2 - Do a final check and ensure the door is level.</li> <li>3 - Check the full open and closed positions and adjust the bump stops if necessary.</li> </ol>
<p><b>Trouble Shooting</b></p>	<ol style="list-style-type: none"> <li>1 - Roller slide difficulties: If the sliding door operation becomes difficult, lubricate the roller carriages and the aluminium overhead track with lubricant or silicone spray to reduce traction between rollers and the aluminium track.</li> <li>2 - Door height uneven: The roller carriages are not in the centre or the door rails are not squared and plumb.</li> </ol>
<p><b>Cleaning</b></p>	<p>Once everything is correctly in place and the job is complete, the glass and plate need to be cleaned. Use a non-abrasive glass cleaner on the glass and warm soapy water on the aluminium extrusion. We also recommend a soft sponge or cloth, again to avoid any risk of scratching.</p>

**IMPORTANT NOTE:** The guide above is simplified, and should in no way be referenced in isolation.

# Juralco Rolline™ Frameless Glass Sliding Door System

## Glass Care and Maintenance

### Glass Cleaning and Maintenance

Architectural glass products must be properly cleaned during the construction period so visual and aesthetic clarity are maintained. Because glass can be permanently damaged if improperly cleaned, glass producers and fabricators recommend strict compliance with the following procedures.

First, determine whether the glass is clear, tinted or reflective. Surface damage is more noticeable on reflective glass compared with the other glass products. If the reflective coated surface is exposed, either on the exterior or interior, special care must be taken when cleaning, as scratches can result in coating removal and a visible change in light transmittance. Cleaning tinted and reflective glass in direct sunlight should be avoided. Cleaning should begin at the top of the building and continue to the lower levels.

Commence cleaning by soaking the glass surfaces with clean water and a soap solution to loosen dirt or debris. Then, using a mild, non-abrasive commercial window washing solution, uniformly apply the solution to the glass surfaces with a non-abrasive applicator and follow with a squeegee to remove all of the cleaning solution from the glass surface.

Ensure that no metal parts of the cleaning equipment touch the glass surface and that no abrasive particles are trapped between the glass and the cleaning materials. All water and cleaning solution residue should be dried from the window gaskets, sealants and frames.

### Scratches and Metal Scrapers

Scratches can occur from hard pointed objects or poor handling, but most often occurs from the careless removal of foreign matter from the glass surface.

Mortar splatter and paint are common offenders and efforts to remove after hardening almost always lead to surface damage. It is essential that the foreign materials are removed before they harden. Better still, if construction work continues after glazing, that the glazed areas are protected by adhesive plastic films or suitable tarpaulins or covers.

One of the common mistakes made by non-glass trades people, including glass cleaning contractors, is the use of razor blades or other metal scrapers on a large portion of the glass surface. Using large blades to scrape a window clean carries considerable risk of causing damage to the glass.

The glass industry, fabricators, distributors and installers neither condones nor recommends any scraping of glass surfaces with metal blades or knives. Such scraping usually permanently damages or scratches the glass surfaces. When paint or other construction materials cannot be removed with normal cleaning procedures, a new 25mm razor blade may have to be used. The razor blade should be used on small spots only. Cleaning should be done in one direction only. Never scrape in a back and forth motion as this could trap particles under the blade that could scratch the glass.

Blades or scrapers can dislodge "pickup" on toughened glass. There are fine particles of glass that are fused on to the surface during toughening. Once dislodged they can scratch the glass.

---

### **Glass Cleaning, Do's and Don'ts**

#### **DO NOT..**

- Do Not - Use Scrapers of any type or size on a Glass surface
- Do Not - Leave building dirt or residues to remain on Glass for a period of time.
- Do Not - Begin cleaning glass until you have identified the surface type.
- Do Not - Clean Glass surfaces in direct sunlight.
- Do Not - Allow dirty water or cleaning residues to remain on the Glass.
- Do Not - Begin cleaning before rinsing off a loose residues.
- Do Not - Use abrasive cleaning solutions, materials or solvents.
- Do Not - Allow metal parts of the cleaning equipment to come in contact with the Glass.
- Do Not - Trap abrasive particles between the cleaning material and the Glass.

#### **DO...**

- Clean glass promptly when dirt or building residues appear.
- Determine glass surface type.
- Exercise special care when cleaning coated surfaces.
- Avoid cleaning glass surfaces in direct sunlight.
- Start cleaning at the top of a building, then continue to lower levels.
- Soak the glass surface in a clean soapy solution before cleaning.
- Use a mild non abrasive commercial cleaner.
- Use a squeegee to remove all cleaning solution.
- Try your procedures on a small window and check.
- Caution other trades re the care and protection of the glass surfaces.

**Residues of surface grit may be present from the toughening production process.  
These grit particles must not be dragged across the surface.  
NEVER use Metal Scrapers**