



 JURALCO

# JURALCO 800 SERIES WARDROBE DOOR SYSTEM

ISSUE 9-20 v1

# Juralco 800 Series Wardrobe Door Systems

Juralco Aluminium Building Products Ltd designs and distributes specialist aluminium joinery systems through a national network of franchised fabricators and agents.

For more than 25 years we have been at the forefront of specialist aluminium door and window products suitable for New Zealand joinery and building methods. Our comprehensive product range includes security and insect screens, balustrades and gates, shutters and awnings, shower screens, wardrobe doors and organisers and internal doors.

The 800 Series is a traditional wardrobe door system with rear mounted bottom rollers offering a choice of a rounded fully framed or semi-frameless look panels. The large adjustable wheel carriage and rear mounted configuration allow for maximum adjustment for out of level floors while still providing smooth quiet panel movement. Popular infills such as painted Gib-Board or safety Mirror can be used to blend with room decor. Doors can be custom-made in a variety of powder-coat colours as well as polished bright anodised or satin anodised finishes

This Guide is intended for use by Architects, Specifiers and Fabricators  
Pages 2-3 cover areas of general interest. Pages 4 onwards are intended for Fabricators

Shown below are some typical 800 system Door solutions for this family house .



All pages © Copyright Juralco Aluminium Building Products Ltd, 2020

## Juralco 800 Series Wardrobe Door System - Typical Layouts

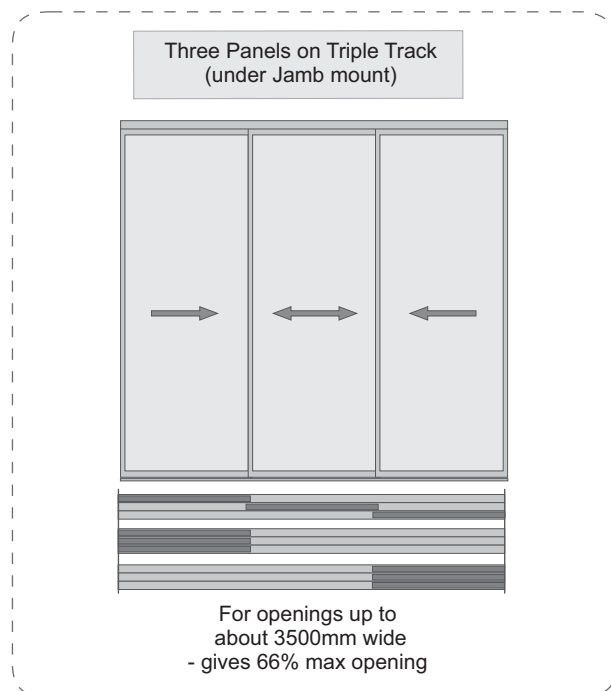
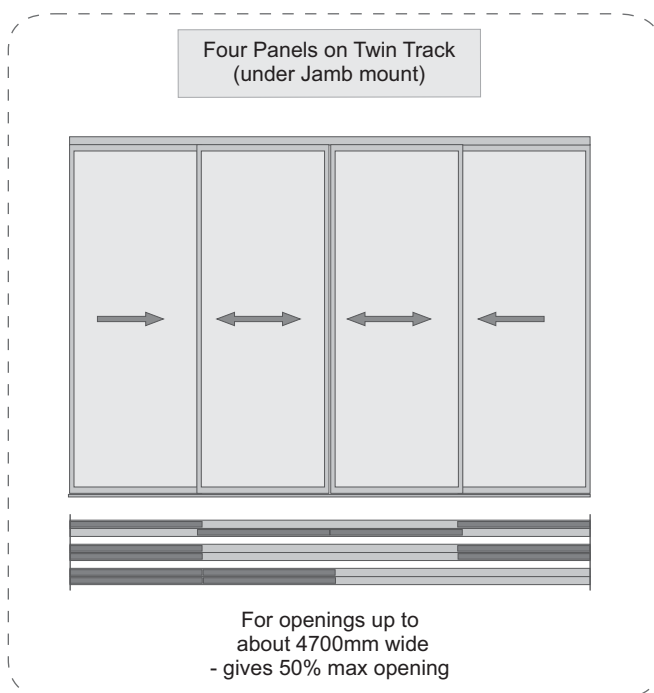

### General Description

- Panels max height 2400mm, max width 1200mm recommended
- Top Track Install - normally Reveal mounted.
- Bottom Track installs direct to Floor on a Packer
- Aluminium Extrusions - A range of standard and custom powder-coat and anodised finishes Contact Juralco.
- Infill Panels - Panel board, Mirror and Gib infills up to 10mm in thickness
- Handles - incorporated in stile extrusion
- Stile Infill Buffer - Wide range of colour co-ordinated colours
- Adjustable Bottom Rollers - Convex Nylon and Steel Rollers
- Weight - up to 60kg Per Panel
- Quiet Smooth Operation

**Important Note:** to conform to NZS4223.3.2016 regulations vinyl backed safety mirror must have a minimum thickness of 4mm with a maximum fully framed area of 2.0m<sup>2</sup>. If the wardrobe system is used as a partition between rooms annealed glass can be used with a minimum thickness of 5mm and maximum area of 0.5m<sup>2</sup> per panel

**Juralco 800 Series Wardrobe Door Systems - Extrusions**

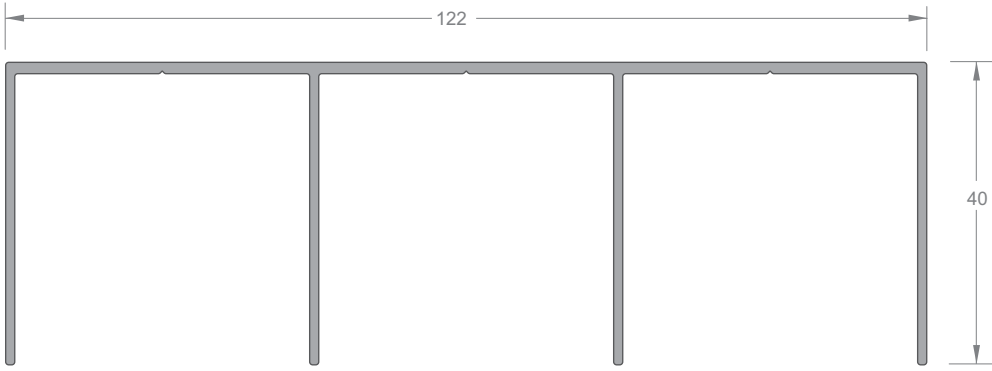

**TRIPLE TOP TRACK**  
Part No 8228

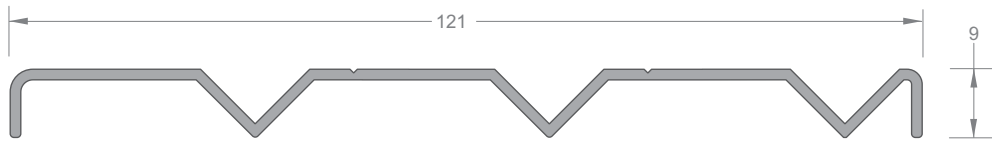

**TRIPLE BOTTOM TRACK**  
Part No 8227



**DOUBLE TOP TRACK**  
Part No 8218

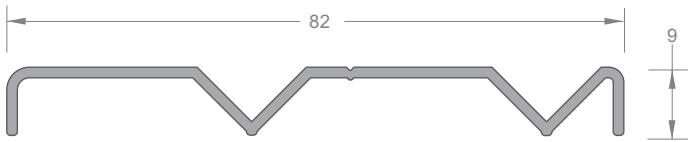

**DOUBLE BOTTOM TRACK**  
Part No 8217

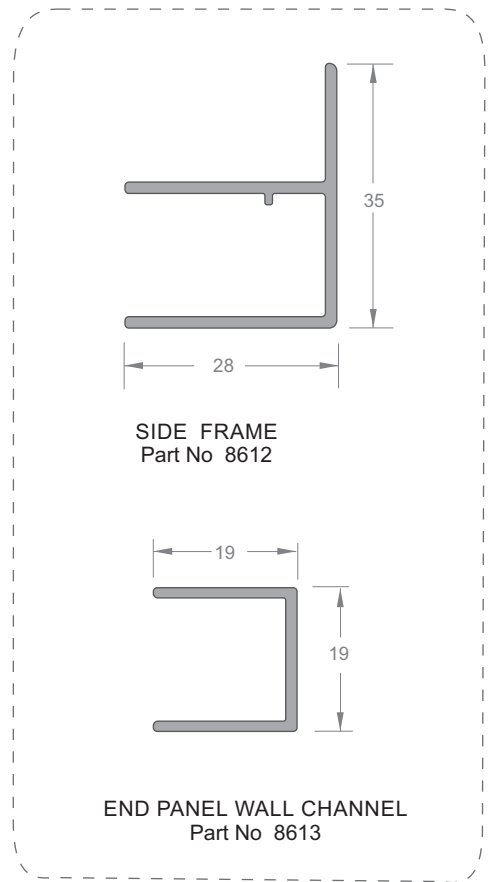

**SIDE FRAME**  
Part No 8612

**END PANEL WALL CHANNEL**  
Part No 8613

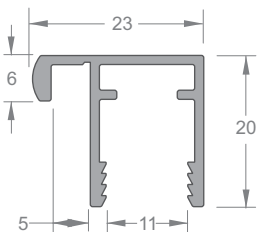

**TOP & BOTTOM RAIL**  
(Frameless type)  
Part No 8230

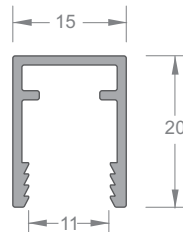

**TOP & BOTTOM RAIL**  
Part No 8216

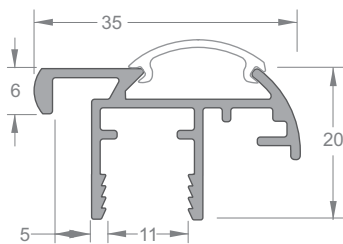

**STILE (Frameless type)**  
Part No 8229

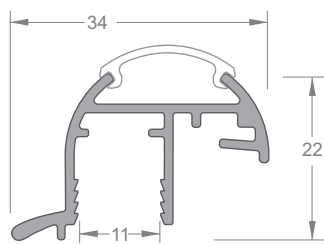

**STILE**  
Part No 8215

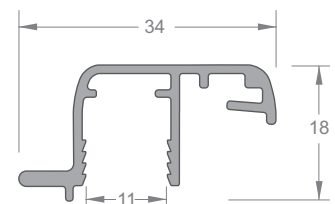

**STILE (Flat Type)**  
Part No 8235

## Juralco 800 Series Wardrobe Door System - Components

Glass Gasket 4mm  
Part No D04

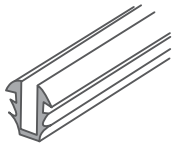

1mm Glazing Wedge  
Part No D12



Glazing Wedges

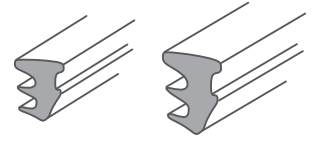

Infill Buffer  
Part No D02

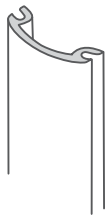

Top Corner Bracket  
Part No D06

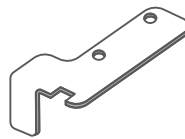

( LH & RH pair)

Head Channel Spacer  
Part No D05



( LH & RH pair)

Double sided Tape  
Part No X01

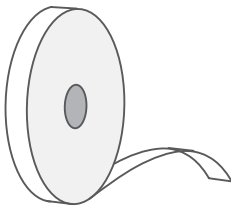

1mm thick

Wardrobe Door Wheel  
Part No D03

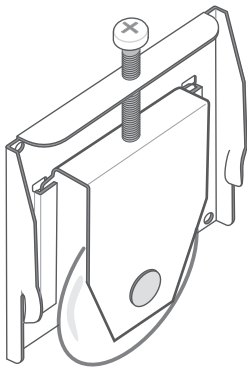

# Juralco 800 Series Wardrobe Door System - Typical Sections and Features

## Typical Vertical Cross sections

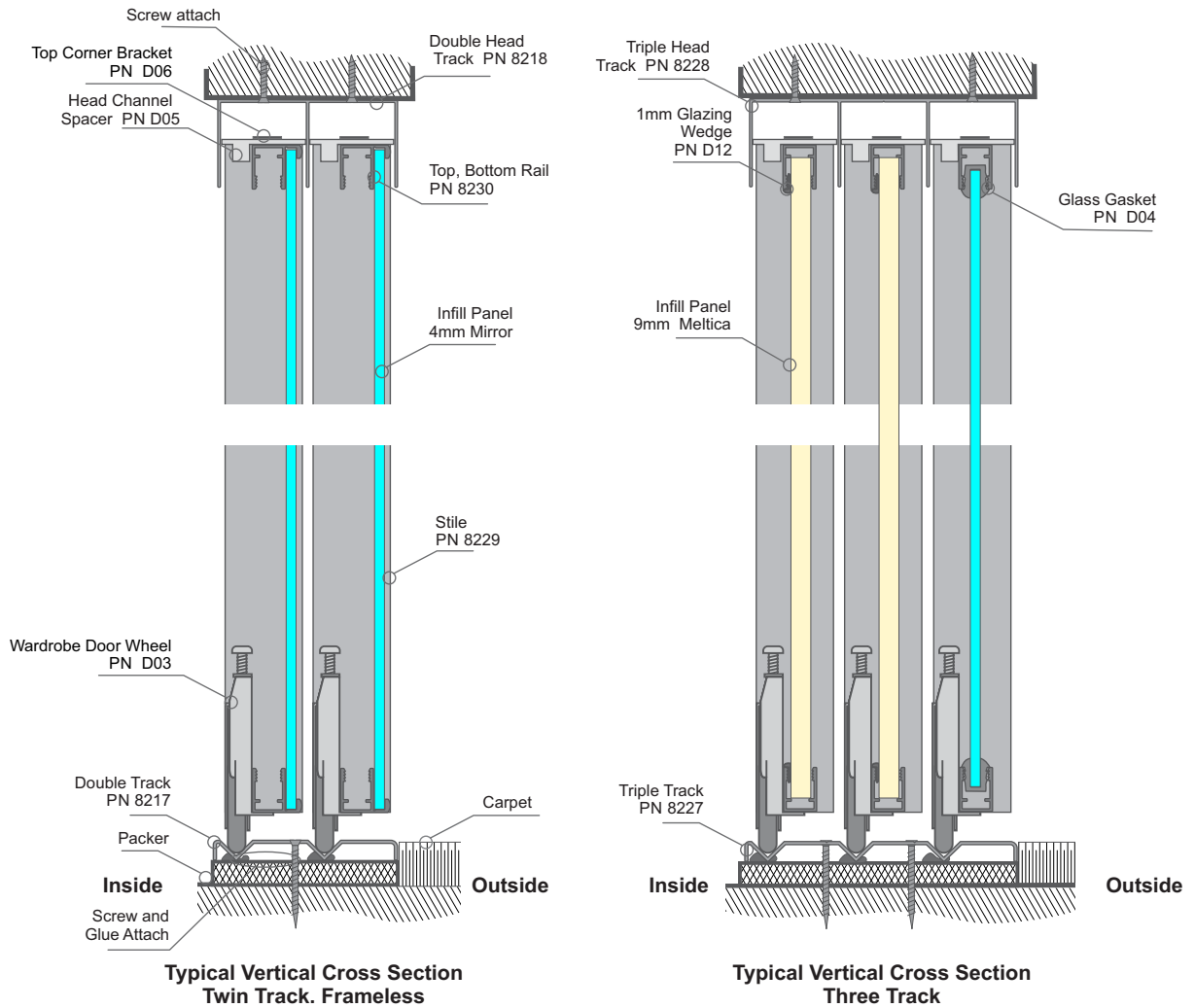

## Typical Horizontal Cross sections

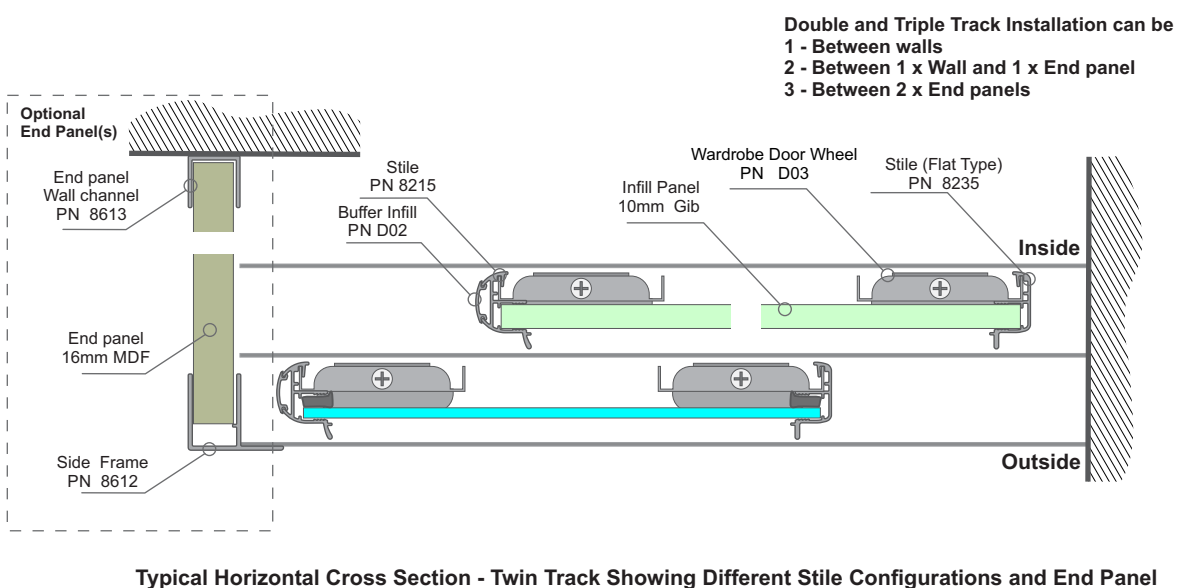

# Juralco 800 Series Wardrobe Door System - Cutting and Infill Allowances

## Infill Height allowances

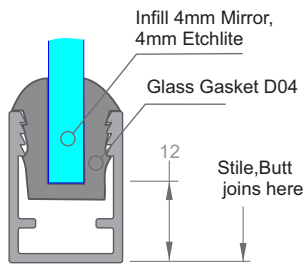

TOP & BOTTOM RAIL  
Part No 8216

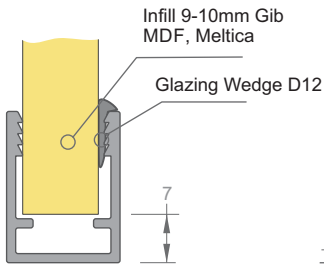

TOP & BOTTOM RAIL  
Part No 8216

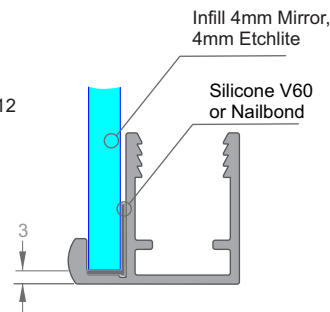

TOP & BOTTOM RAIL  
(Frameless type)  
Part No 8230

## Rail cutting allowances

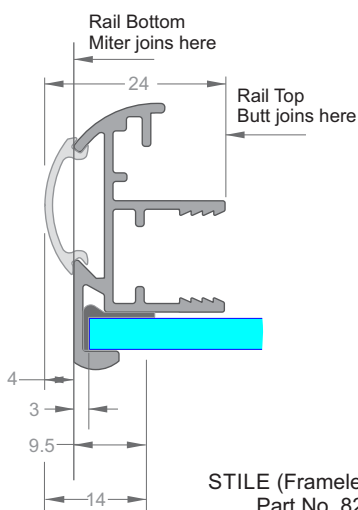

STILE (Frameless type)  
Part No 8229

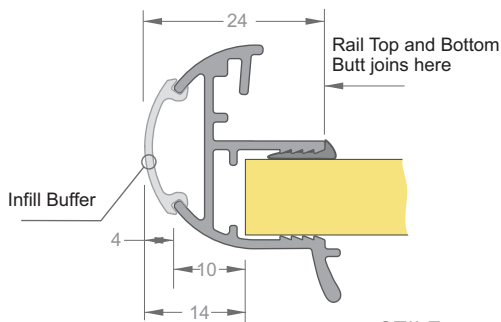

STILE  
Part No 8215

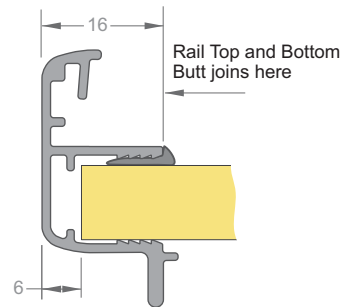

STILE (Flat Type)  
Part No 8235

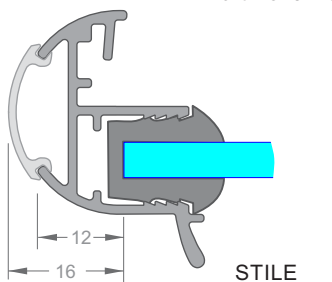

STILE  
Part No 8215

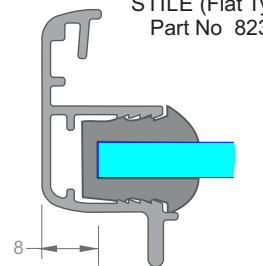

STILE (Flat Type)  
Part No 8235

## Stile and Infill Buffer Overlaps

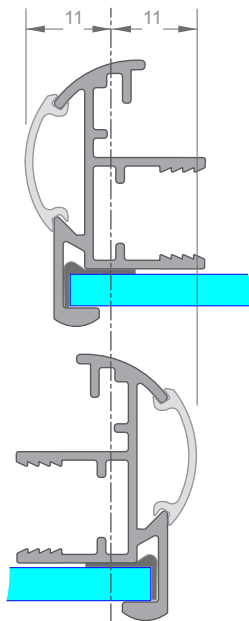

STILE (Frameless type)  
Part No 8229

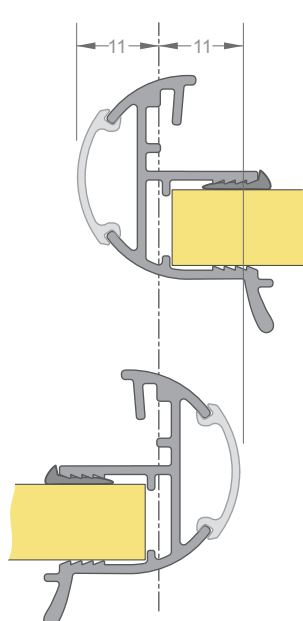

STILE  
Part No 8215

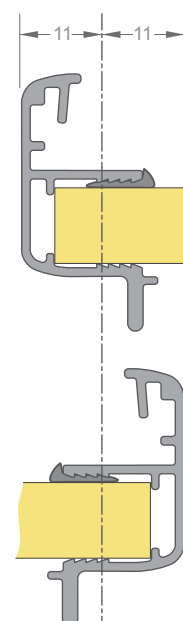





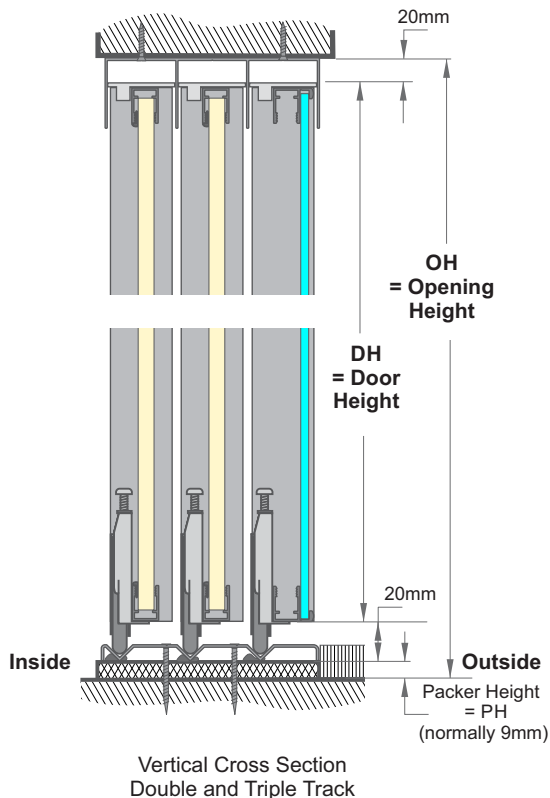

STILE (Flat Type)  
Part No 8235

# Juralco 800 Series Wardrobe Door System - Cutting



## ALL DOORS - HEIGHT CUTTING FORMULA

|   | HEIGHTS  | Part       | Formula in mm  |
|---|--|------------|--|
| 1 | Single Door - Overall Height = DH                        |            | $OH - PH - 40 = DH$  |
| 2 | Door, Stiles 8215, 8235                                  | 8215, 8235 | DH    |
| 3 | Door, Stiles 8229 Frameless, miter bottom                | 8229       | DH    |
| 4 | Door, Infill Buffer for Stiles 8215, 8229                | D02        | DH   |
| 5 | Infill, MDF, Meltica, Gib, for Rail 8216 + Glazing Wedge | NA         | DH - 14  |
| 6 | Infill, 4mm Mirror, 4.75mm Seratone for Rail 8216 + D04  | NA         | DH - 24   |
| 7 | Infill, 4mm Mirror, 4.75mm Seratone for Rail 8230        | NA         | DH - 6    |

Note : Mirror, Glass panel size imitations . Refer to page 3



## Juralco 800 Series Wardrobe Door System - Cutting

Typical Horizontal Cross Section Double Track - Under Jamb Mount

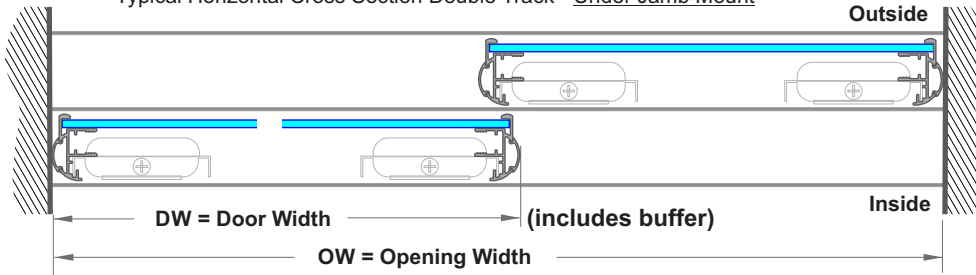

- NOTES :**  
 1 - Door Width includes Infill Buffer D02 = 8mm total per door, for Stiles 8215 and 8229  
 2 - For height cutting formula refer page F5

### DOUBLE TRACK, TWO DOORS, CUTTING FORMULA

|    | WIDTHS   | Part | Formula in mm             |
|----|--|------|---------------------------|
| 1  | Double Head Track  | 8218 | <b>OW</b>                 |
| 2  | Double Track   | 8217 | <b>OW</b>                 |
| 3  | <b>Single Door - Overall Width = DW</b>                  |      | <b>OW / 2 + 11 (= DW)</b> |
| 4  | Door , Top and Bottom Rail for Stile <b>8215</b>         | 8216 | <b>DW - 48</b>            |
| 5  | Infill, MDF, Meltica, Gib for Stile 8215 + Glazing Wedge | NA   | <b>DW - 28</b>            |
| 6  | Infill, 4mm Mirror, 4.75mm Seratone for Stile 8215 + D04 | NA   | <b>DW - 32</b>            |
| 7  | Door , Top Rail for Stile <b>8229 Framless</b>           | 8230 | <b>DW - 48</b>            |
| 8  | Door , Bottom Rail for Stile 8229 Framless, miters       | 8230 | <b>DW - 8</b>             |
| 9  | Infill, 4mm Mirror, Safety Glass, 4.75mm Seratone + D04  | NA   | <b>DW - 14</b>            |
| 10 | Door , Top and Bottom Rail for Stile <b>8235</b>         | 8216 | <b>DW - 32</b>            |
| 11 | Infill, MDF, Meltica, Gib for Stile 8235 + Glazing Wedge | NA   | <b>DW - 12</b>            |
| 12 | Infill, 4mm Mirror, 4.75mm Seratone for Stile 8235 + D04 | NA   | <b>DW - 16</b>            |

**Note : Mirror, Glass panel size imitations . Refer to page 3**

Typical Horizontal Cross Section Double Track - Under Jamb Mount

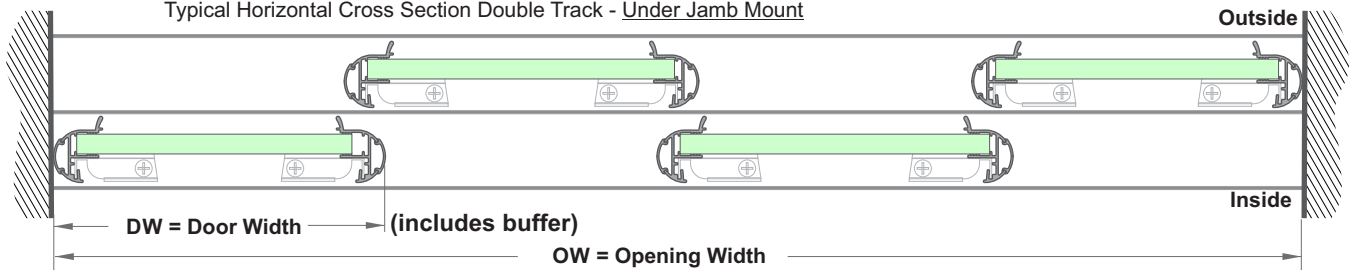

### DOUBLE TRACK, FOUR DOORS, CUTTING FORMULA

|    | WIDTHS   | PART | Formula in mm             |
|----|--|------|---------------------------|
|    | ITEM   |      |                           |
| 1  | Double Head Track  | 8218 | <b>OW</b>                 |
| 2  | Double Track   | 8217 | <b>OW</b>                 |
| 3  | <b>Door= Single Door , Overall Width = DW</b>            |      | <b>OW / 4 + 16 (= DW)</b> |
| 4  | Door , Top and Bottom Rail for Stile <b>8215</b>         | 8216 | <b>DW - 48</b>            |
| 5  | Infill, MDF, Meltica, Gib for Stile 8215 + Glazing Wedge | NA   | <b>DW - 28</b>            |
| 6  | Infill, 4mm Mirror, 4.75mm Seratone for Stile 8215 + D04 | NA   | <b>DW - 32</b>            |
| 7  | Door , Top Rail for Stile <b>8229 Framless</b>           | 8230 | <b>DW - 48</b>            |
| 8  | Door , Bottom Rail for Stile 8229 Framless, miters       | 8230 | <b>DW - 8</b>             |
| 9  | Infill, 4mm Mirror, Safety Glass, 4.75mm Seratone + D04  | NA   | <b>DW - 14</b>            |
| 10 | Door , Top and Bottom Rail for Stile <b>8235</b>         | 8216 | <b>DW - 32</b>            |
| 11 | Infill, MDF, Meltica, Gib for Stile 8235 + Glazing Wedge | NA   | <b>DW - 12</b>            |
| 12 | Infill, 4mm Mirror, 4.75mm Seratone for Stile 8235 + D04 | NA   | <b>DW - 16</b>            |

**Note : Mirror, Glass panel size imitations . Refer to page 3**

## Juralco 800 Series Wardrobe Door System - Cutting

Typical Horizontal Cross Section Triple Track - Under Jamb Mount

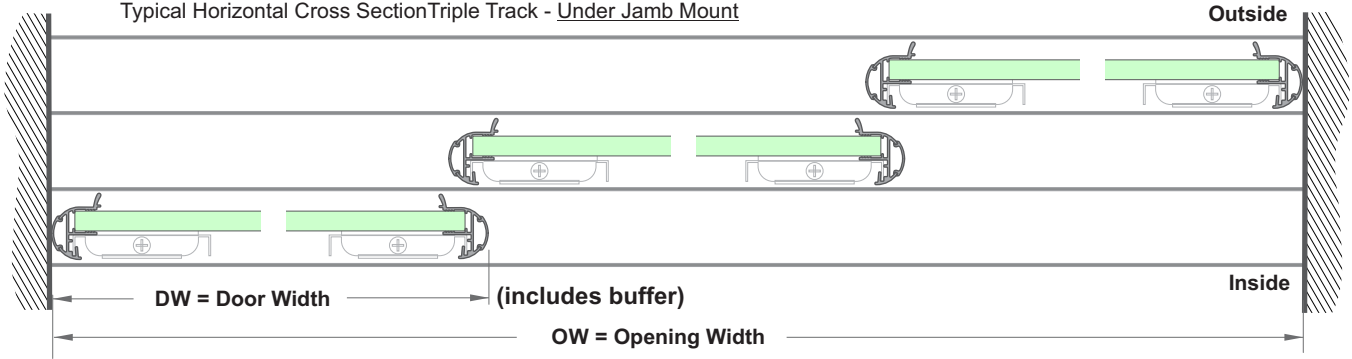

### TRIPLE TRACK, THREE DOORS, CUTTING FORMULA

|    | WIDTHS   | PART | Formula in mm             |
|----|--|------|---------------------------|
|    | ITEM   |      |                           |
| 1  | Triple Head Track  | 8228 | <b>OW</b>                 |
| 2  | Triple Track   | 8227 | <b>OW</b>                 |
| 3  | <b>Door = Single Door , Overall Width = DW</b>           |      | <b>OW / 3 + 15 (= DW)</b> |
| 4  | Door , Top and Bottom Rail for Stile 8215                | 8216 | <b>DW - 48</b>            |
| 5  | Infill, MDF, Meltica, Gib for Stile 8215 + Glazing Wedge | NA   | <b>DW - 28</b>            |
| 6  | Infill, 4mm Mirror, 4.75mm Seratone for Stile 8215 + D04 | NA   | <b>DW - 32</b>            |
| 7  | Door , Top Rail for Stile 8229 Framless                  | 8230 | <b>DW - 48</b>            |
| 8  | Door , Bottom Rail for Stile 8229 Framless, miters       | 8230 | <b>DW - 8</b>             |
| 9  | Infill, 4mm Mirror, Safety Glass, 4.75mm Seratone + D04  | NA   | <b>DW - 14</b>            |
| 10 | Door , Top and Bottom Rail for Stile 8235                | 8216 | <b>DW - 32</b>            |
| 11 | Infill, MDF, Meltica, Gib for Stile 8235 + Glazing Wedge | NA   | <b>DW - 12</b>            |
| 12 | Infill, 4mm Mirror, 4.75mm Seratone for Stile 8235 + D04 | NA   | <b>DW - 16</b>            |

**Note : Mirror, Glass panel size imitations . Refer to page 3**

DT = Depth

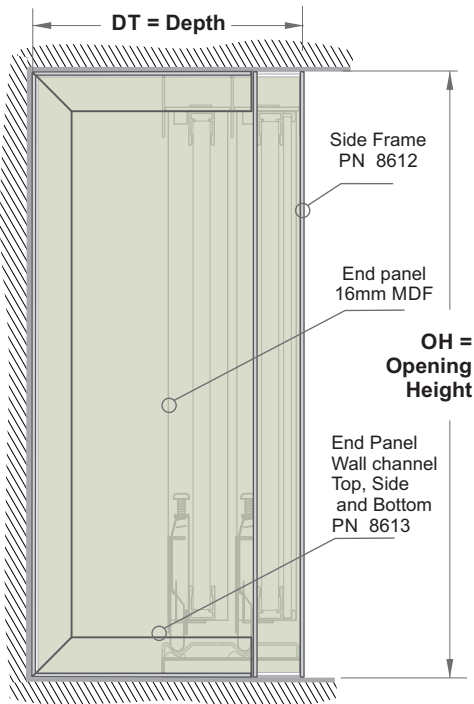

### END PANELS, CUTTING FORMULA

|   | ITEM                                  | PART | Formula in mm  |
|---|---------------------------------------|------|----------------|
| 1 | Side Frame - Height                   | 8612 | <b>OH</b>      |
| 2 | Wall Channel - Height ( Miter ends)   | 8613 | <b>OH</b>      |
| 3 | Wall Channel - Depth ( 1 x Miter end) | 8613 | <b>DT - 28</b> |
| 4 | Infill - 16mm MDF - Height            | NA   | <b>OH - 3</b>  |
| 5 | Infill - 16mm MDF - Depth             | NA   | <b>DT - 20</b> |



# Juralco 800 Series Wardrobe Door System - Assembly, Setout, Machining

This page - Construction, assembly Details  
For 8215, 8235 Stiles, and 8216 Rail

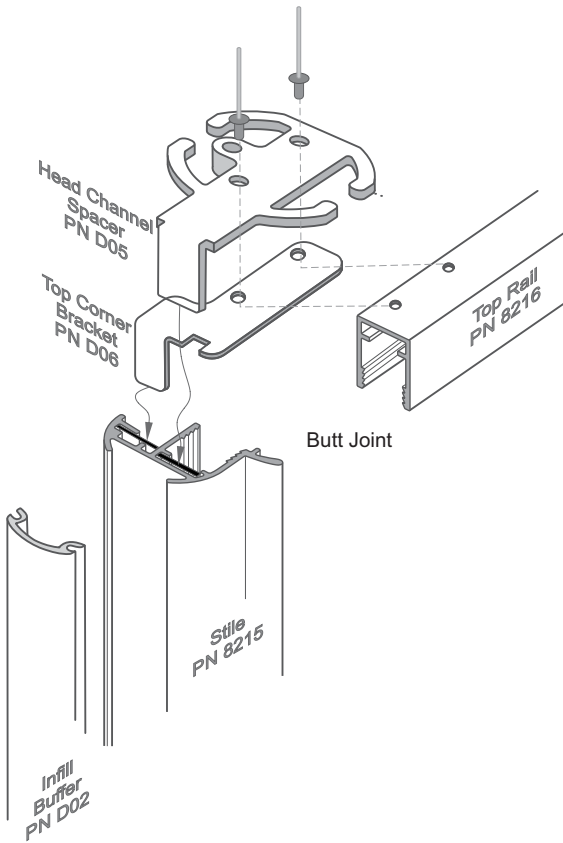

View from Frontside, Top Corner

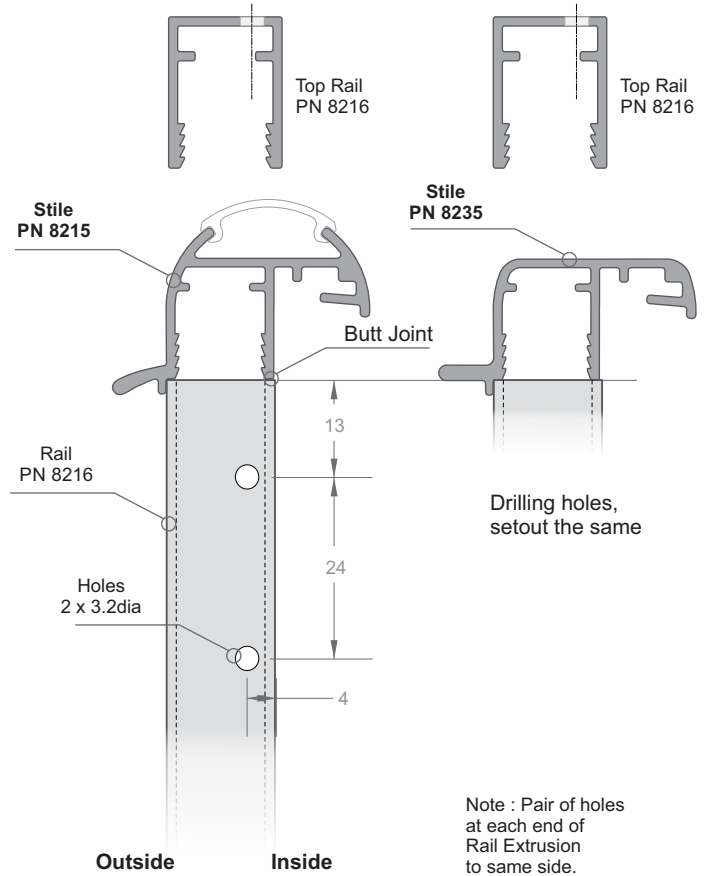

Machining - Top Corner

Note : Pair of holes at each end of Rail Extrusion to same side. Brackets LH, RH pair

Note : Once installed this Top corner not visible

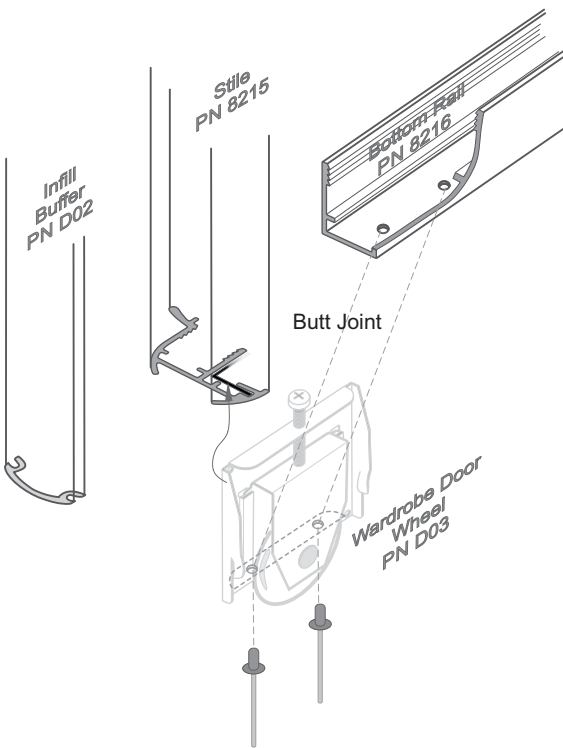

View from Backside, Bottom Corner

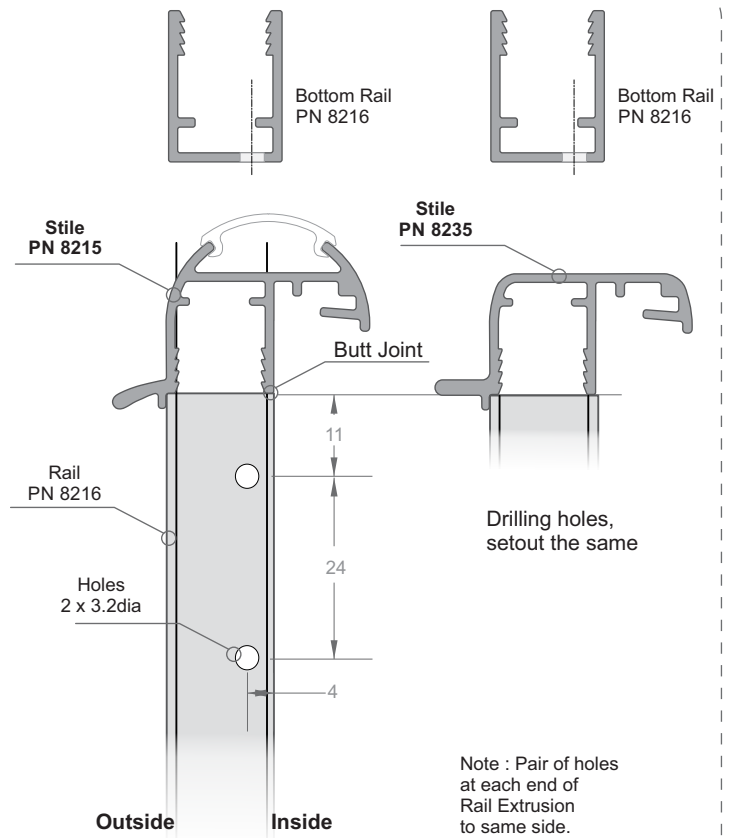

Machining - Bottom Corner

Note : Pair of holes at each end of Rail Extrusion to same side. Brackets LH, RH pair

# Juralco 800 Series Wardrobe Door System - Assembly, Setout, Machining

This page - Construction, assembly Details  
For 8229 Framless Stile, and 8230 Rail

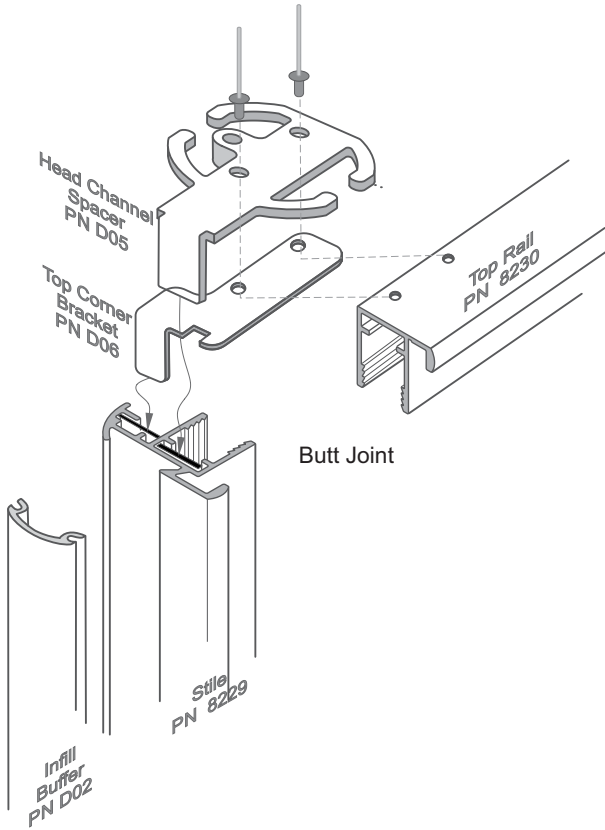

View from Frontside, Top Corner

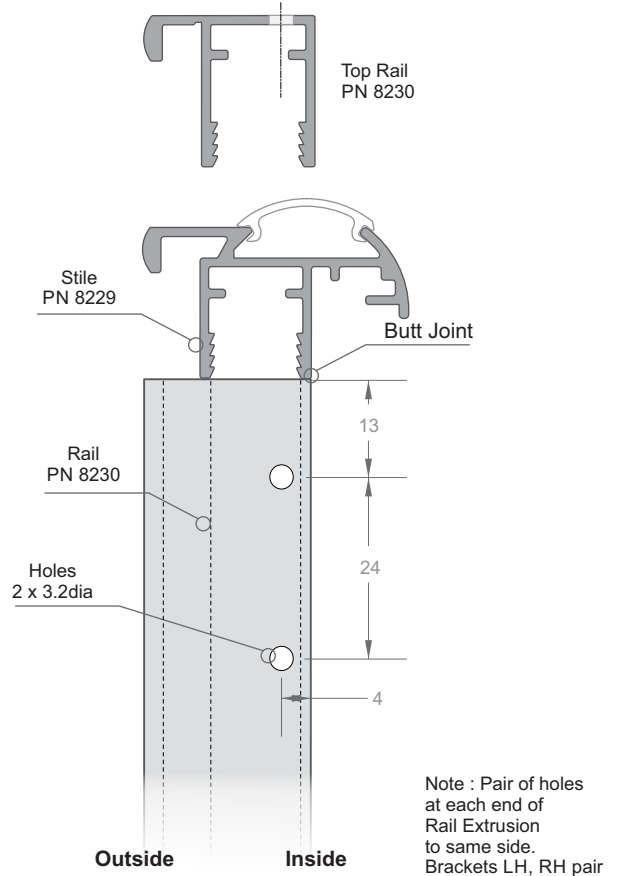

Machining - Top Corner

Note : Pair of holes at each end of Rail Extrusion to same side. Brackets LH, RH pair  
Note : Once installed this Top corner not visible

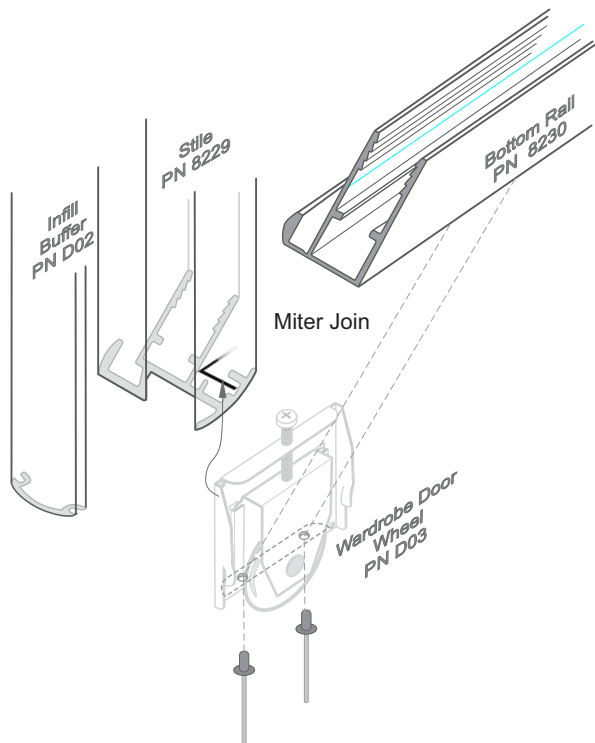

View from Backside, Bottom Corner

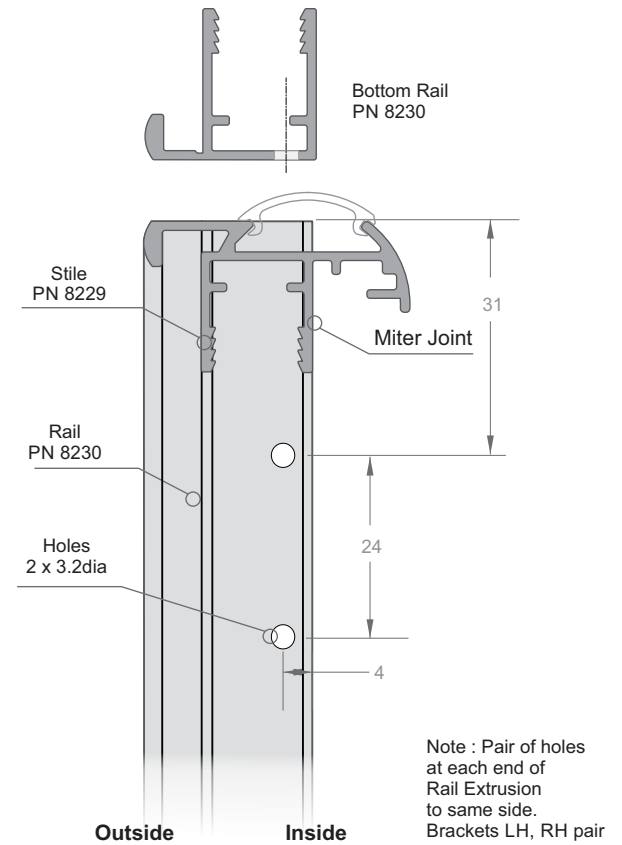

Machining - Bottom Corner

Note : Pair of holes at each end of Rail Extrusion to same side. Brackets LH, RH pair

## Recommended Manufacturing, Assembly and Installation Procedures

### Manufacture

- 1- Hands must be clean and free from oils and grease.
- 2 - Inspect aluminium extrusions to ensure they are free of extrusion or surface finishing defects.
- 3 - Cut aluminium extrusions to size as per cutting formula.
- 4 - Cut infill to size as per cutting formula.

### Assembly, Frame type

- 1 - Ensure work area is clean and free from chips dust. Hands must be clean and free from oils and grease.
- 2 - Solid Infills - Run a bead of Panelbond along the top face of the stiles first ,then top and bottom rails.  
Leave overnight.

**Mirror** - Place the mirror face upwards on blocks, raising the mirror off the work bench by approximately 30 mm.

Run the Glass Gasket wrap around mirror edge starting from one of the top corners.

(If done this way Vinyl Wrap join is not readily visible). Note: Do not overstretch wrap as it may pull away at top join.

**Gib or Wood Panel** Glaze with No 22 or D12 Wedge or other if necessary to the backside of the panel.

- 3 - Centre and press on both stiles ensuring handle grip is to mirror or best panel side.
- 4 - Press on both Top and Bottom Rails.
- 5 - Slide left and right hand Top Corner Brackets into stile cavity with bracket holes showing on top of Top Rail.
- 6 - **Carefully** drill through bracket holes into Top Rail. **Do not** drill too deep as drill bit will damage mirror if it strikes the glass.  
You may wish to use a stop on the drill bit.
- 7 - Place Head Channel Spacers on top of each Top Corner Bracket locating one end of Spacer into stile cavity.  
Rivet together using 73 AS44 rivets. Remove plastic block attached to Spacer and using a 25 mm x 8 Gauge screw, screw through from bottom of spacer into plastic block.
- 8 - Slide Door Rollers into stile cavity and locate firmly against Bottom Rail. Again, most carefully drill through the Bottom Rail and fix Rollers to Rail using 73 AS44 rivets.
- 9 - Fit buffer insert to stiles.

### Assembly, Framless, Mirror Infill

- 1 - Lay the Mirror face downwards flat on the bench.
- 2 - Using a Stile, mark and carefully remove the vinyl strip all the way around the mirror.
- 3 - Dry assemble the Frame in two L Shaped sections (stile and rail) with a wheel on one section and a top Bracket on the other.  
Predrill all the other holes.
- 4 - Run a bead of V60 silicone along the centre of each stile/rail assembly, then carefully push the two assemblies over the mirror edges
- 5 - Carefully insert the other wheel and top cover and rivet all into place.
- 6 - Leave on the bench 24 hrs to cure

### Installation - Wardrobe Doors

- 1 - If using the Top/Bottom D08 end caps, fit before installation.
- 2 - Fixing of Top Track to ceilings is to be done with 25mm x 6g screws with wall toggles or similar if needed.  
Where possible, glue the Bottom Track to the floor using 'No More Nails' or similar adhesive. Weigh down until adhesive cured. Ensure they are fitted to the front edge of any timber frame or other finished surface.  
NOTE: it may be necessary to check into existing cornice and skirting board using a sharp chisel to the size of the appropriate track.
- 3 - Lift the back Door Panel, top first, into the Top Track and Wheel Assembly to the Bottom Track. Once aligned on track adjust the Wheel Carriage to ensure an even line between Door Style and wall. For out of square situations, select either the right or left hand Door Panel and adjust appropriately to that wall.
- 4 - Lift in the Front Door Panel and adjust, ensuring the Door Stile aligns with the wall.  
NOTE - For three and four Panel Doors, the rear Doors must be fitted first.

### Installation - Wardrobe Doors, using End Panels

- 1 - Attach End Panel Wall Channel to wall at measured position(s). Screw in place using wall toggles or similar.  
Note - Predrill holes on inside channel upstand, to attach Return Panel.
- 2 - Fit Return Panel(s) in place, fix in place by screws from inside.
- 3 - Attach Top, Bottom Track as in 1 above.
- 4 - Lift Door Panels into place, adjust as in 2,3 above.
- 5 - Fit Side Frame to front of Return Panel.

### Installation - Final

Adjust, align all gaps. Make sure all doors slide easily, quietly. Clean, polish off all fingermarks, leave the site clean and tidy.