



 JURALCO

JURALCO 350 SERIES ARCHITECTURAL DOOR SYSTEM

ISSUE 2-24 v1

Juralco 350 Architectural Door Systems

Juralco Aluminium Building Products Ltd designs and distributes specialist aluminium joinery systems through a national network of franchised fabricators and agents.

For more than 25 years we have been at the forefront of specialist aluminium door and window products suitable for New Zealand joinery and building methods. Our comprehensive product range includes security and insect screens, balustrades and gates, shutters and awnings, shower screens, wardrobe doors and organisers and internal doors.

One of the key design aspects is that in most cases each product is custom-made and installed by our fabricators to suit individual requirements of size, colour and style.

The 350 Series is no exception. The system has been designed to meet present or future design trends in the home or apartment. It can be custom-made in a wide variety of powder-coat or anodised colours with either solid infill or toughened safety glass – with or without mid-rails – top hung or bottom mounted on tracks.

The 350 Series revolutionises the way we consider space. Internal doors are no longer an element of division, but allowing light to flow, modifying surfaces and rooms.

Type	Pages	Description	Use the Bookmarks  List to jump to selected pages
Applications	3 - 4	Shows typical applications and Configurations. Also Powder Coating specifications.	
Top Hung Sliding Doors	5 - 7	Shows Top Hung details. Face fix and between Jambs. Also Extrusion and Components	
	8	Shows Typical Sections and Features	
	9 - 13	Shows Cutting deductions, and Machining details	
Hinged Door	14	Shows Hinged Door using Top Hung items	
Bottom Roller Sliding Doors	15 - 18	Shows Bottom Roller details. Face fix and between Jambs. Also Extrusion and Components	
	19 - 20	Shows Typical Sections and Features incl a Soft Close option	
	21 - 26	Shows Cutting deductions, and Machining details	
Powder coat care	27	Instructions for the care of Powder coated surfaces	



350 Bottom Roller Door



350 Top Hung Door

Juralco 350 Architectural Door Systems - Typical Applications

Shown below are some typical 350 system Door solutions for this house .

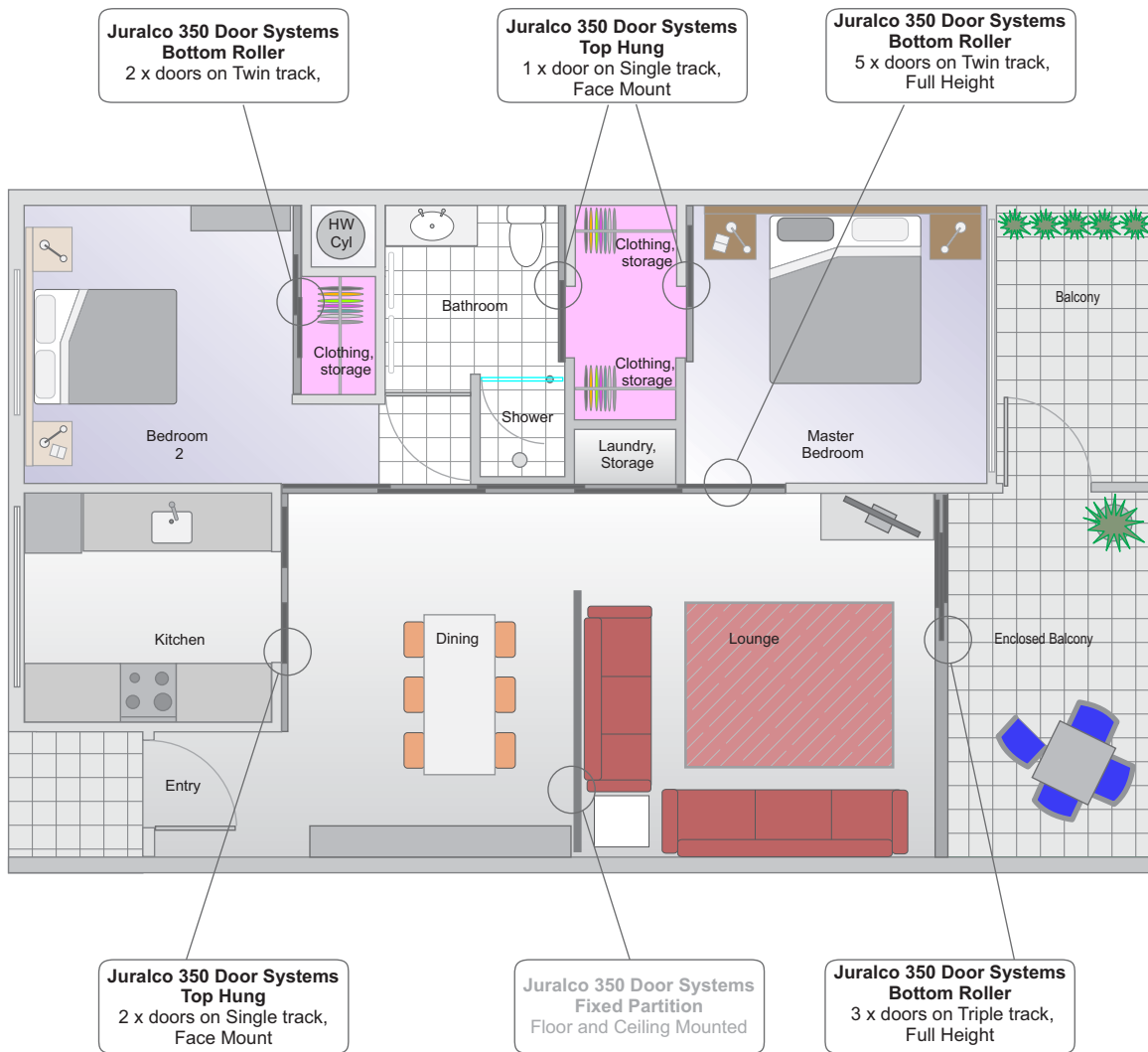

TOP HUNG AND BOTTOM ROLLER DOOR TYPES

The 350 Door System comes in two Basic Types, depending on the application.

- 1 - Top Hung. The Door is hung from Track / Rollers at the top of the Door. At floor level there are no tracks, only small plastic floor guides. This is suitable for contemporary modern houses, as only the top track is visible.
- 2 - Bottom Roller. The door is supported by a shallow floor mounted track. This normally ends up flush with floor coverings. The top of the door is guided inside another track. Suitable for multiple doors moving more than their width.

Important information - Powder Coating systems.

Powdercoat Systems The new standard Dulux powder coating system used by Juralco is Duralloy Plus®. Also Duralloy® and Duratec®. Juralco Powder coated prices are for Duralloy Plus® and Duralloy® (same pricing). Duratec® prices on application.

The following specs apply to Building Exteriors.

- Dulux Duralloy Plus® powder coating systems are suitable for properties greater than 10m from high tide level. Residential and Light commercial buildings, 3 levels max. Warranty 15 yrs
- Dulux Duratec® powder coating systems are suitable for properties greater than 10m from high tide level. All Residential and Commercial buildings. Warranty 25 yrs

Attachment to structures A PVC Tape or similar material spacer must be used to separate powder coated aluminium items from all concrete and steel structures. Failure to do so can lead to the chemicals in the structure affecting the powder coating, leading to corrosion.

Swimming Pools The chlorinated water in swimming pools can cause the deterioration of powder coated surfaces, leading to corrosion of the underlying surface. It is recommended that Powder coated surfaces be 1200mm min from a pool.

Care The Dulux powder coating warranty period is conditional upon the surface being maintained in accordance with the Dulux 'Care and Maintenance Instructions'. Download from Dulux or refer to the back page of this manual.

Juralco 350 Architectural Door Systems - Typical Applications

Top Hung Doors (no bottom Track)

One Panel on Single Track
(Face Mount)

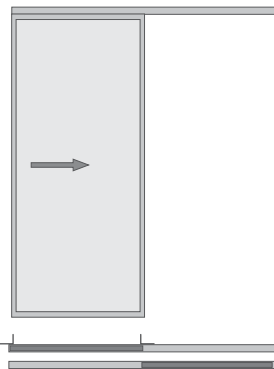

For openings up to
about 1100mm wide
- gives 100% max opening

Two Panels on Single Track
(Face mount)

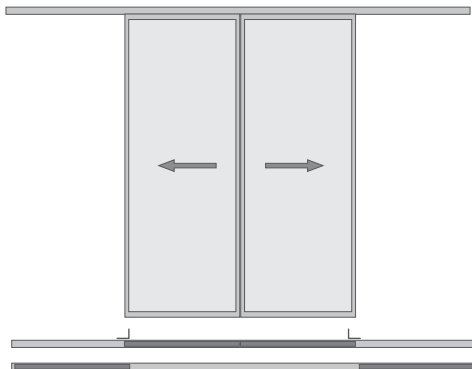

For openings up to
about 2300mm wide
- gives 100% max opening

Two Panels on Two Single Tracks
(between Jamb mount)

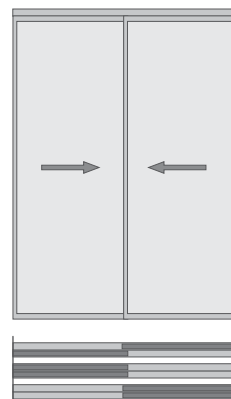

For openings up to
about 2300mm wide
- gives 50% max opening

Bottom Roller Doors

Two Panels on Twin Track
(between Jamb mount)

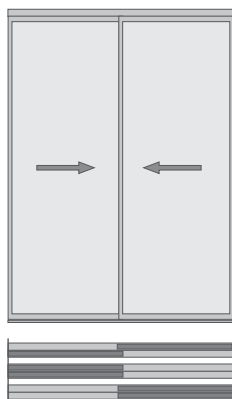

For openings up to
about 2300mm wide
- gives 50% max opening

Four Panels on Twin Track
(between Jamb mount)



For openings up to
about 4700mm wide
- gives 50% max opening

Three Panels on Triple Track
(between Jamb mount)



For openings up to
about 3500mm wide
- gives 66% max opening



Juralco 350 Systems - Top Hung Door, Features, Construction Details

System 1 - Top Hung Type

A Mitered corner type, for Top Hung Rollers only. Recommended for contemporary 1 and 2 Door architectural applications. Can be face mounted or mounted between jambs. Highly engineered for ultra quiet operation and a very long life.

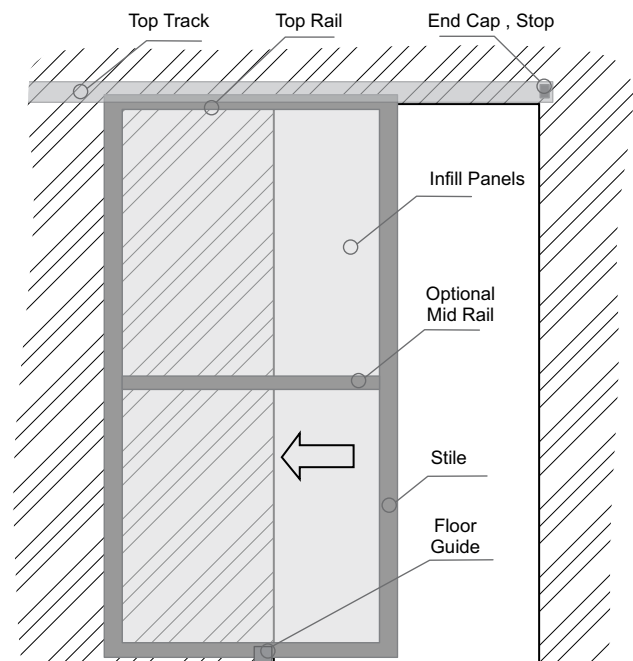

General Arrangement - Face Installation



General Arrangement - Between Jambs Installation

GENERAL DESCRIPTION

- Doors - Max Height 2400mm . Max width 1200mm
- Track mounted stops at end travel with detents
- Aluminium extrusions - a range of standard and custom powder coated and anodized finishes - Contact Juralco
- Auto stackability, both in Top Track and Bottom Floor Guides to automatically align doors
- Strong stable frame with maximum corner rigidity
- Quiet , smooth operation guaranteed
- Flush Handle Hardware
- Hidden fixing system - no visible plugs, caps.
- Easy positive, on site door height adjustment
- Max weight per panel 35kg

INFILL TYPES

- Infill panel location - PVC co-extrusion has a solid body and flexible tongues - firmly locates infill panels in the extrusion in a stylish and minimal manner
- Glass Panels - 4 to 5mm thickness, Safety Mirror, Etchlite, Sandblasted, Applied Films.
- Plastic Panels, 4 to 5mm thickness, Polycarbonate or Acrylic Translucent
- Melteca Panels 9mm, Colours
- MDF, 9mm, Gib 10mm for Painting
- Melteca Panels 18m, Colours, Decorative stripping.

Important Note: to conform to NZS4223.3.2016 regulations vinyl backed safety mirror must have a minimum thickness of 4mm with a maximum fully framed area of 2.0m². If the wardrobe system is used as a partition between rooms annealed glass can be used with a minimum thickness of 5mm and maximum area of 0.5m² per panel

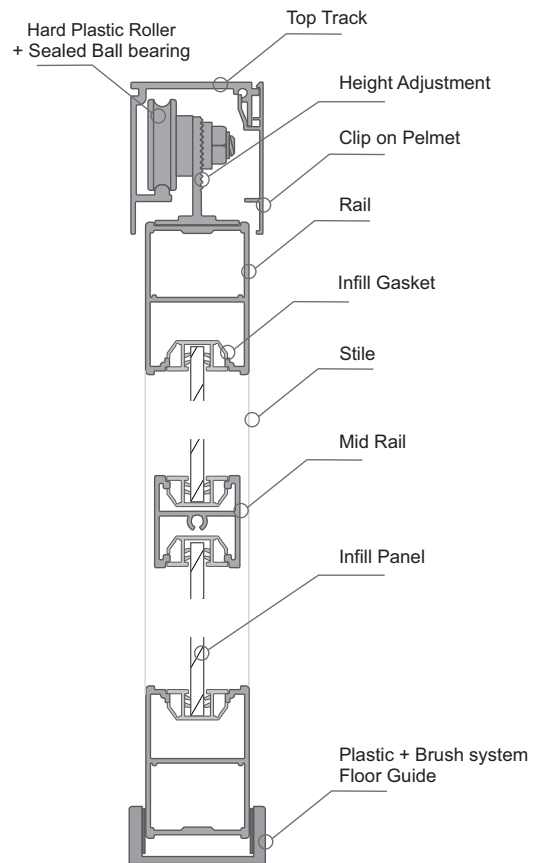

A typical cross section showing Major components (nts)

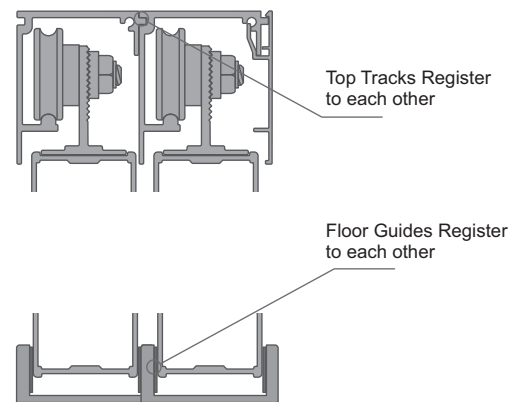

A typical cross section showing Top Track / Floor Guide Stackability (nts)

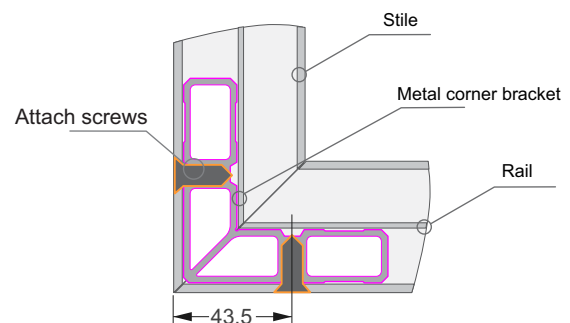

Juralco 350 Systems - Top Hung Door Extrusions

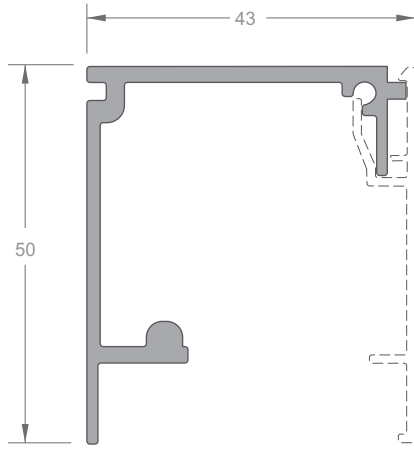

TOP TRACK
Part No 3511

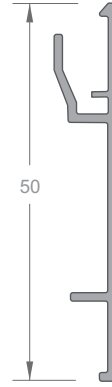

TOP TRACK PELMET
Part No 3512

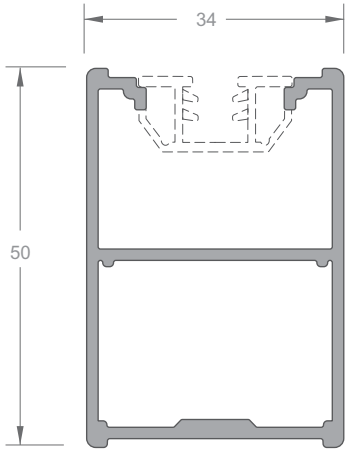

STILE / RAIL
Part No 3515

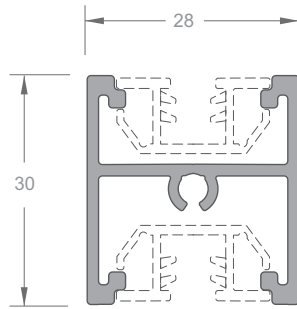

MID RAIL
Part No 3522

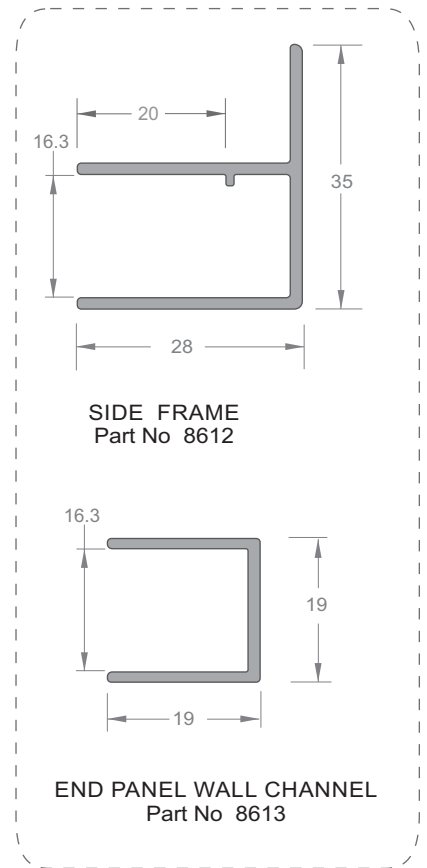

SIDE FRAME
Part No 8612

END PANEL WALL CHANNEL
Part No 8613

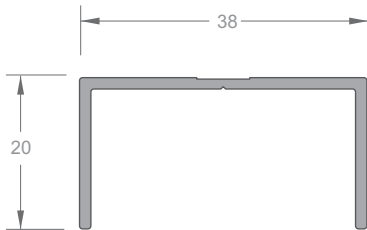

WALL CHANNEL
Part No 504

Juralco 350 Systems - Top Hung Door Components

Wheel Bracket
Part No W53 (pair)

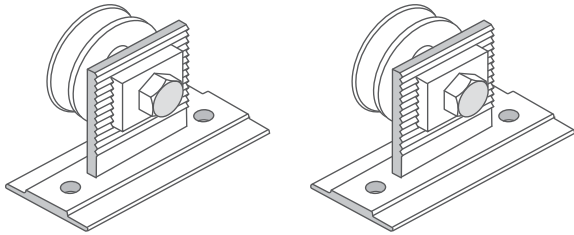

Mitre Bracket
Part No W57

Screws Included
(2 per bracket)

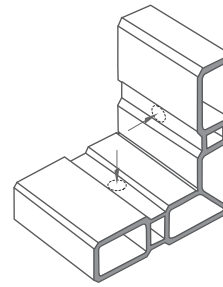

Drill for 18gx3/4 SS
C/S Self Tapper screws

External Floor Guide
Part No W59

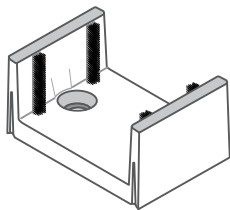

Top Track Door Stop
Part No W52

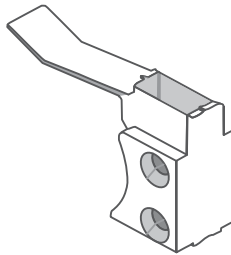

Track End Cap
Part No W58 (pair)

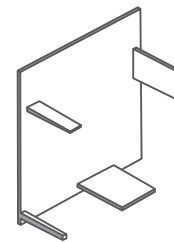

Gaskets, Inserts

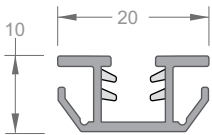

INFILL GASKET - SMALL
Panels 4mm - 5mm
Part No W51/2.6

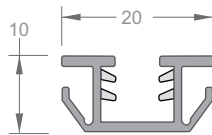

INFILL GASKET - MEDIUM
Panels 6mm - 8mm
Part No W60/2.6

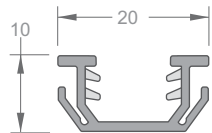

INFILL GASKET - LARGE
Panels 9mm - 10mm
Part No W55/2.6

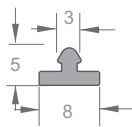

8mm INSERT
Part No 3521

Flush Pull Handle
Part No W56

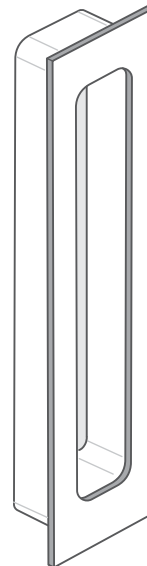

Juralco 350 Systems - Top Hung Door, Typical Sections and Features

Typical Vertical Sections

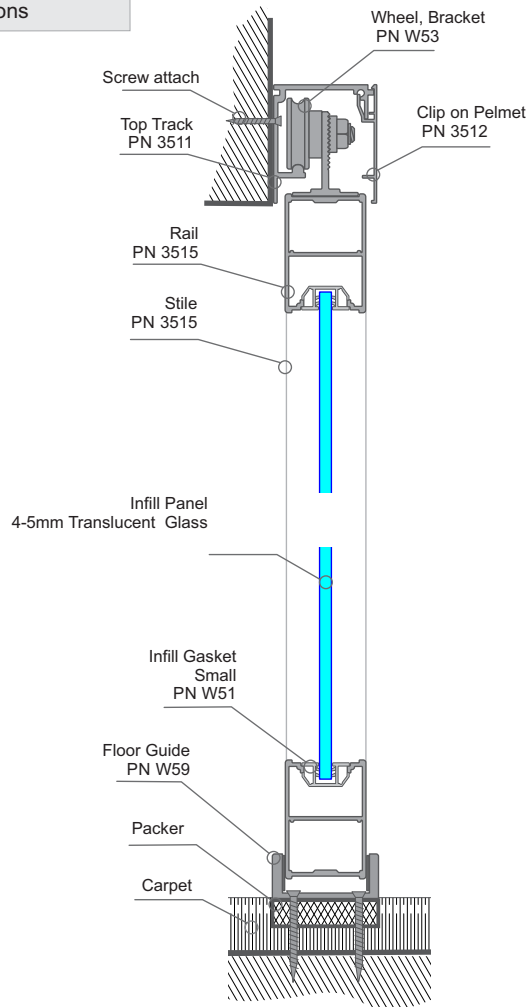

**Typical Vertical Cross Section
Single Track, Face Mount**

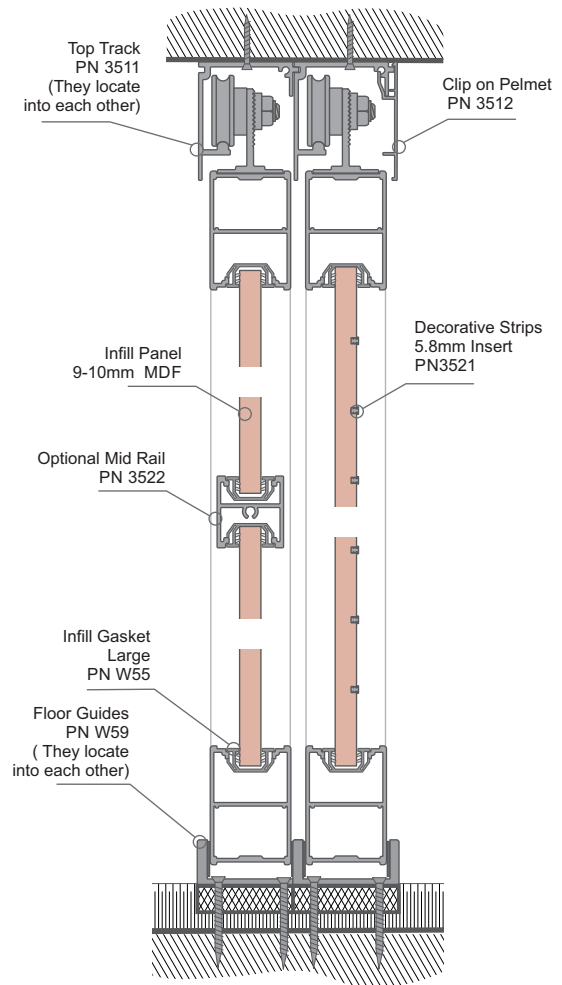

**Typical Vertical Cross Section
Twin Track, Under Jamb Mount**

Typical Horizontal Sections

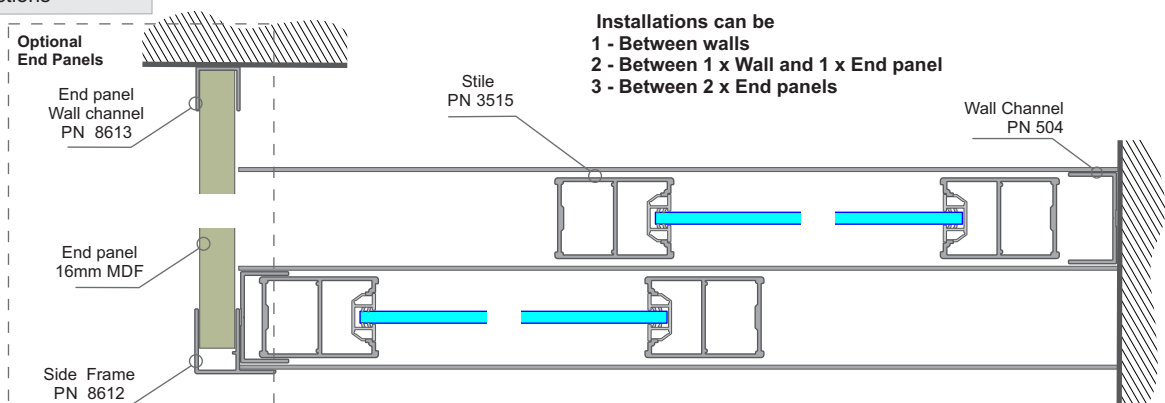

Typical Horizontal Cross Section - Twin Track Showing Optional End Panel

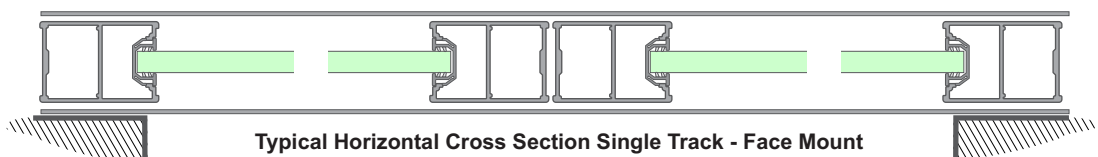

Typical Horizontal Cross Section Single Track - Face Mount

Juralco 350 Systems - Top Hung Door, Cutting and Infill Allowances

Rail Cutting Allowances

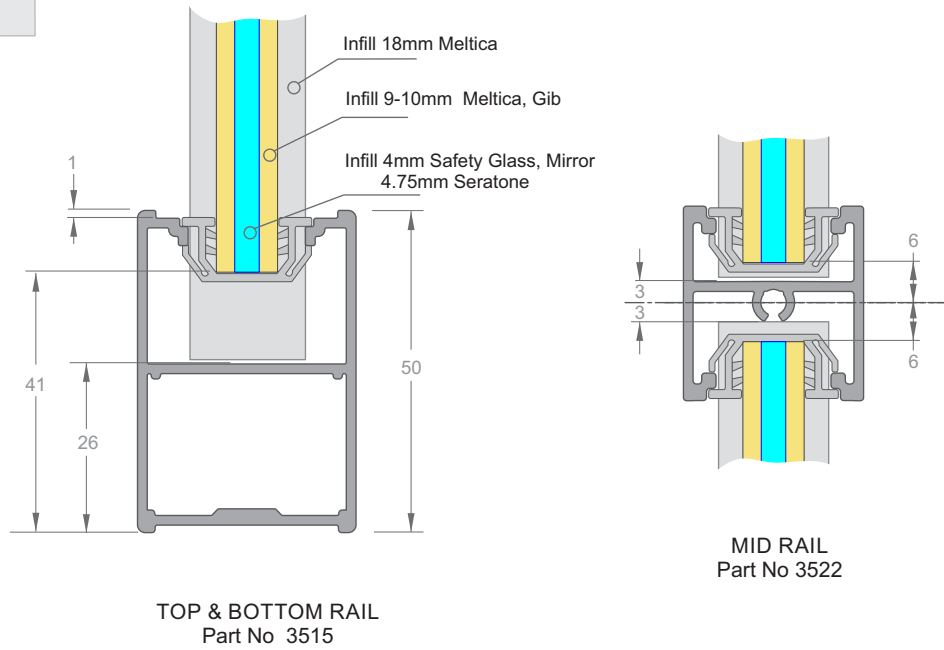

Stile Cutting Allowances

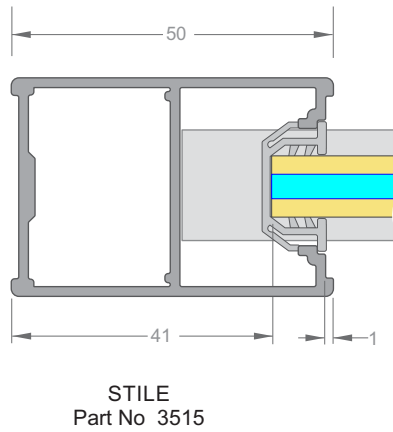

Stile Overlaps

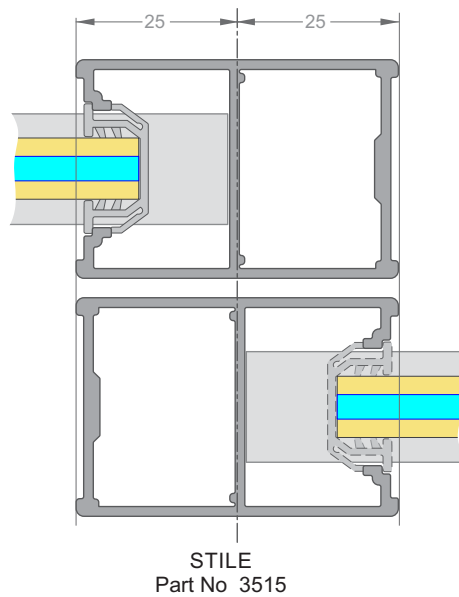

Juralco 350 Systems - Top Hung Door Cutting

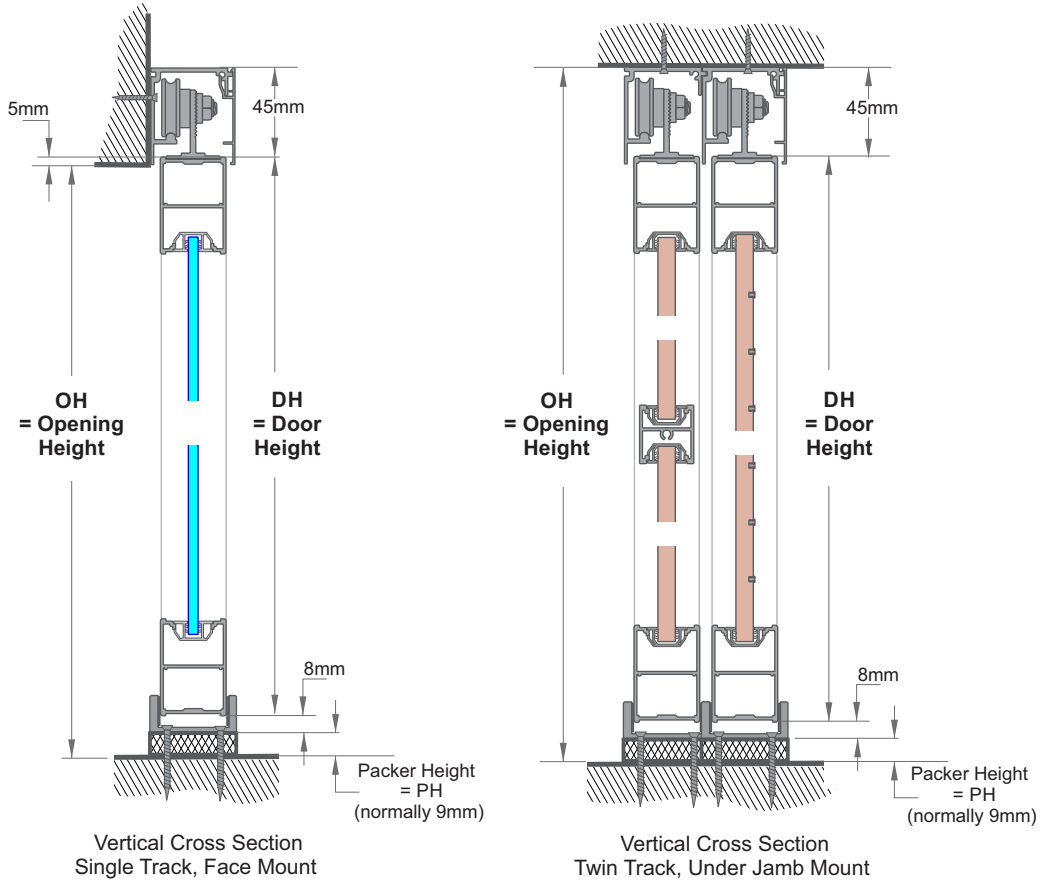

TOP HUNG DOORS - HEIGHT CUTTING FORMULA

HEIGHTS - FACE MOUNT		Part	Formula in mm
1	Single Door - Height = DH		$OH - PH - 3 (= DH)$
2	Stiles incl Miter	3515	DH
3	Infill Gasket	W51, W55	DH - 52
4	Infills, 4mm - 10mm Glass, MDF, Meltica, Gib	NA	DH - 82
5	Infills, 18mm Meltica (no Gasket)	NA	DH - 52

HEIGHTS - UNDER JAMB MOUNT		Part	Formula in mm
1	Single Door - Height = DH		$OH - PH - 53 (= DH)$
2	Stiles incl Miter	3515	DH
3	Infill Gasket	W51, W55	DH - 52
4	Infills, 4mm - 10mm Glass, MDF, Meltica, Gib	NA	DH - 82
5	Infills, 18mm Meltica (no Gasket)	NA	DH - 52
6	Wall Channel (trim to architrave)	504	DH

Note : Mirror, Glass panel size imitations . Refer to page 5

Juralco 350 Systems - Top Hung Door Cutting

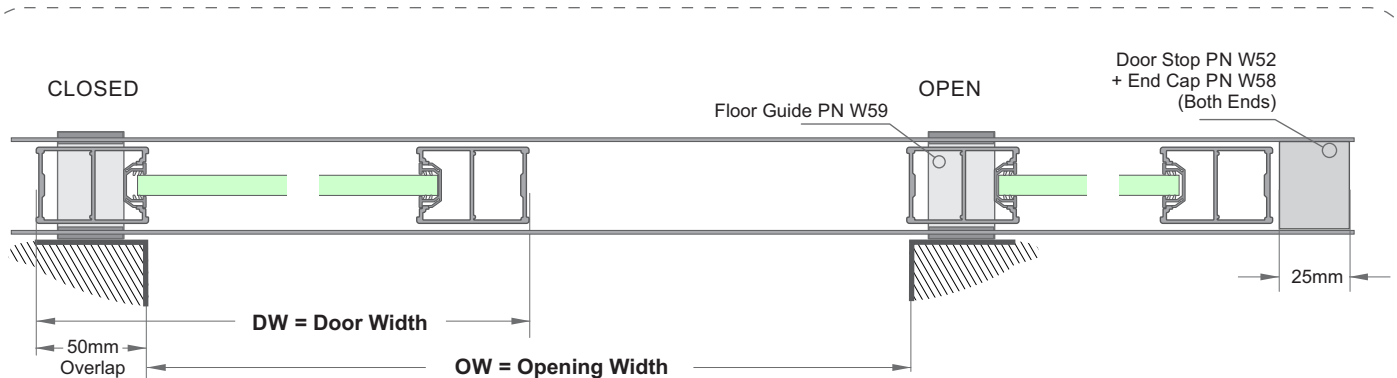

Typical Horizontal Cross Section Single Track - Face Mount

SINGLE TRACK, ONE or TWO DOORS - WIDTH CUTTING FORMULA

WIDTHS - ONE DOOR		Part	Formula in mm
1	Top Track	3511	$2 \times OW + 150$
2	Top Track Pelmet	3512	$2 \times OW + 150$
3	Single Door, Width = DW		$OW + 100 \quad (= DW)$
WIDTHS - TWO DOORS		Part	Formula in mm
1	Top Track	3511	$2 \times OW + 150$
2	Top Track Pelmet	3512	$2 \times OW + 150$
3	Single Door, Width = DW		$OW/2 + 50 \quad (= DW)$
WIDTHS		Part	Formula in mm
1	Top, Bottom Rail incl Miters	3515	DW
2	Infill Gasket	W51, W55	$DW - 98$
3	Infills, 4mm - 10mm Glass, MDF, Meltica, Gib	NA	$DW - 82$
4	Infills, 18mm Meltica (no Gasket)	NA	$DW - 52$
5	Mid Rail	3522	$DW - 98$

Note : Mirror, Glass panel size imitations . Refer to page 5

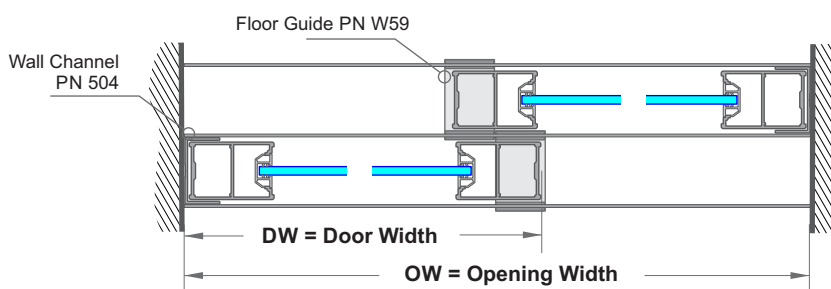

Typical Horizontal Cross Section Single Track - Under Jamb Mount

TWO TRACKS, TWO DOORS - WIDTH CUTTING FORMULA

WIDTHS		Part	Formula in mm
1	Top Track	3511	OW
2	Top Track Pelmet	3512	OW
3	Single Door, Width = DW		$OW / 2 + 25 \quad (= DW)$
4	Top, Bottom Rail incl Miters	3515	DW
5	Infill Gasket	W51, W55	$DW - 98$
6	Infills, 4mm - 10mm Glass, MDF, Meltica, Gib	NA	$DW - 82$
7	Infills, 18mm Meltica (no Gasket)	NA	$DW - 52$
8	Mid Rail	3522	$DW - 98$

Note : Mirror, Glass panel size imitations . Refer to page 5

Juralco 350 Systems - Top Hung Door Cutting

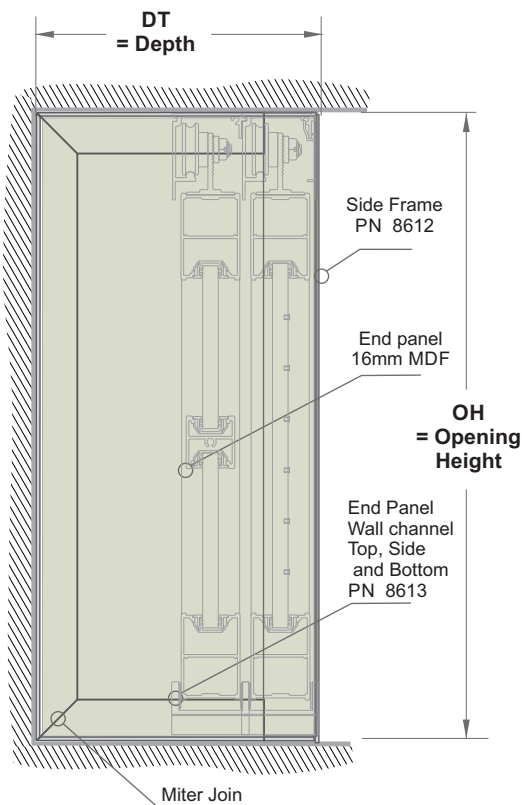

END PANELS, CUTTING FORMULA

	ITEM	PART	Formula in mm
1	Side Frame - Height	8612	OH
2	Wall Channel - Height (Miter ends)	8613	OH
3	Wall Channel - Depth (1 x Miter end)	8613	DT - 28
4	Infill - 16mm MDF - Height	NA	OH - 4
5	Infill - 16mm MDF - Depth	NA	DT - 20

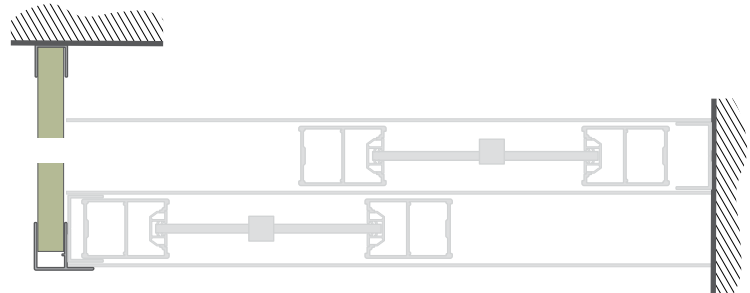

Recommended Manufacturing & Assembly procedure for Top Hung Panels

- 1 - Ensure work area is clean and free from dust. Hands must be clean and free from dirt / oils.
- 2 - Inspect aluminium extrusions to ensure they are free of extrusion or surface finishing defects.
- 3 - Cut aluminium extrusions to size following the cutting instructions.
- 4 - Rout and insert handles in stiles and drill holes in top & bottom rails and stiles as per instructions (see next page)
- 5 - Drill for wheels on the top rail.
- 6 - Fit Miter Brackets to top and bottom of each stile, insert screws firmly.
- 7 - Cut glazing inserts and infill to size as per cutting formula.
- 8 - Run the vertical Infill gasket to the Door maximum internal height as per Fig 1 below.
Fit the infill gasket to the edges of the infill by raising the infill face upwards on blocks and gently tapping with a soft mallet. The midrail (if used) assembly screw will then lock it in place
- 9 - Centre and press on top and bottom rail.
- 10 - Centre and press on both stiles ensuring that the handle is facing the best panel side.
Tap to ensure miters are tight and panel is square.
- 11 - Insert screws into miter brackets on the top and bottom rails.
Adjust frame as required then screw up firmly
- 12 - Insert wheels onto the top rail, attach.
- 13 - Clean off all fingermarks, leave site clean and tidy.

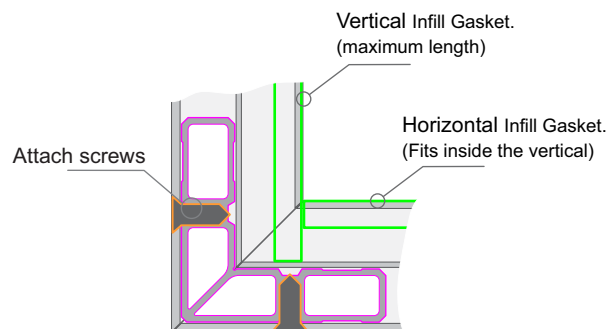
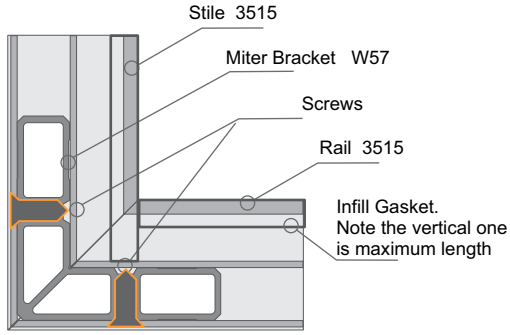

Fig 1

Juralco 350 Systems - Top Hung Door Machining Details

Miter Corner Join

Note - The vertical Infill gaskets = maximum internal height.
Screw thru the gasket at the midrail if used. This will lock it in place



Step 3 - Assemble. Note Screw on Vertical Face visible

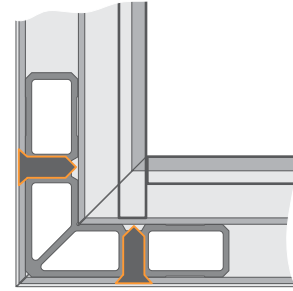

Step 1 - Machining

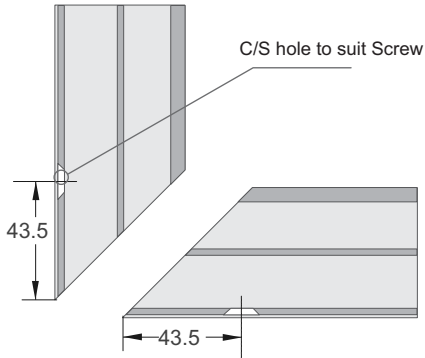

Decorative Inset

Standard - 4 x Inserts per Door

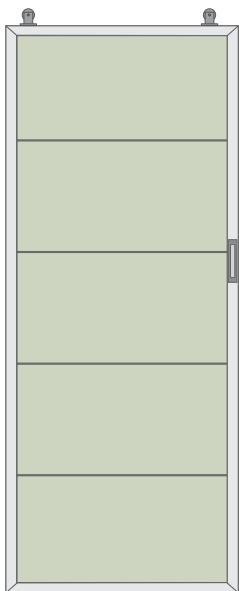

Refer FabSys for cutting dimensions

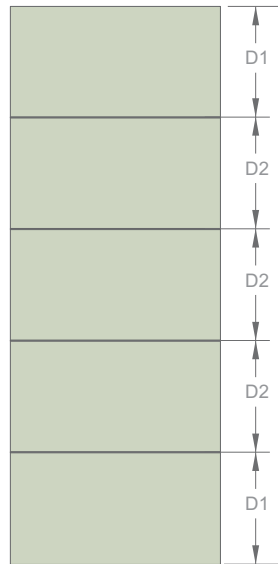

INFILL OPTIONS

- 1 - Safety Mirror 4mm
- 2 - Etchlite Glass 4mm
- 3 - MDF 9mm
- 4 - Gib10mm
- 5 - Meltica 9mm
- 6 - Meltica 18mm (for inserts)

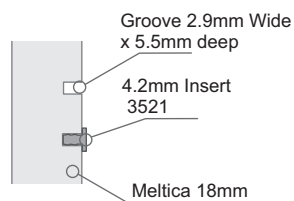

Flush Handle

Standard - 2 x Handles per Door

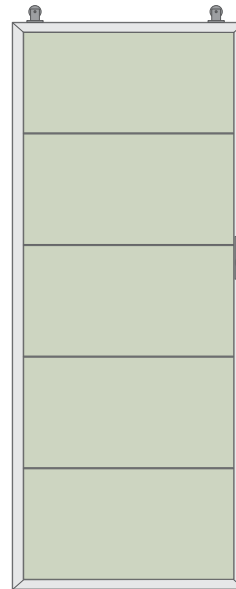

Flush Pull Handle W56

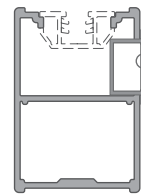

Handle in Rear Position

Flush Pull Handle W56

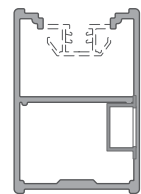

Handle in Front Position

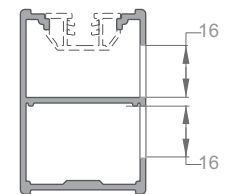

Handle Slot
16mm Wide x 85mm Deep

Juralco 350 Systems - Hinged Door (Top Hung Type)

350 Hinged Door

For Reveal mounting only
Use Magnetic clip(s) at Top
Use appropriate Handle

Closing Angle JC3737
Topside only

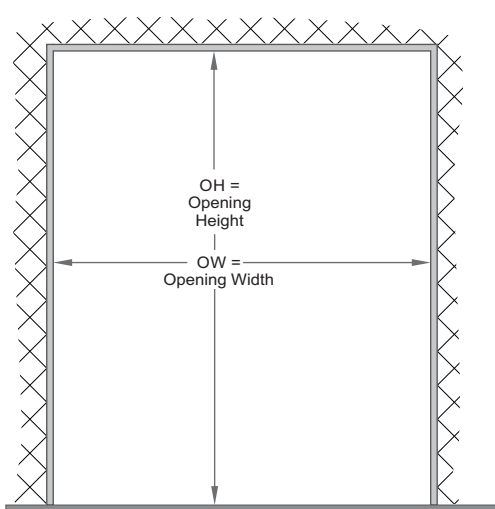

Double Door Opening

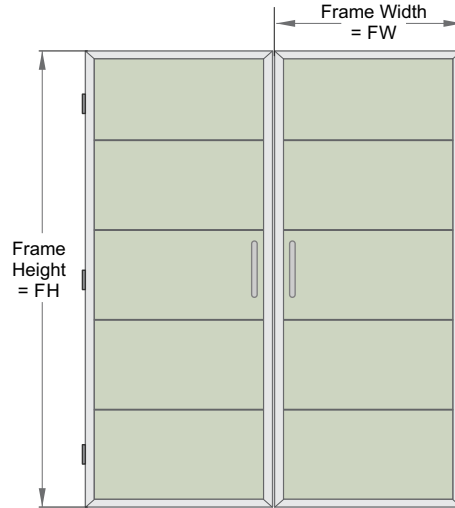

OH = Opening Height

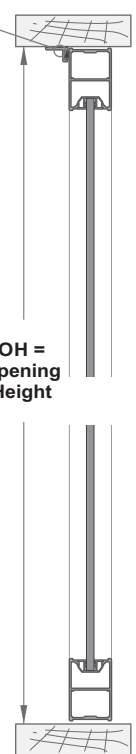

Typical Vertical Section - Door 3515 Frame and JC 242 Security Hinges

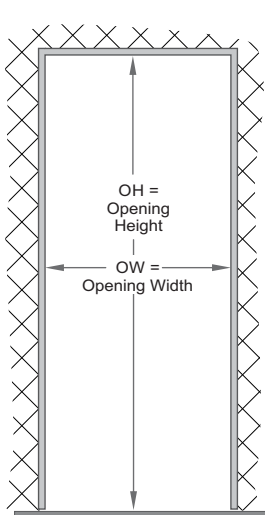

Single Door Opening

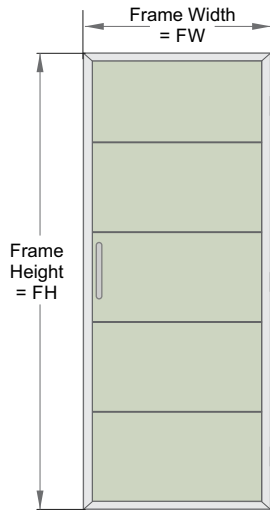

JC 242 Security Hinges

OW = Opening Width

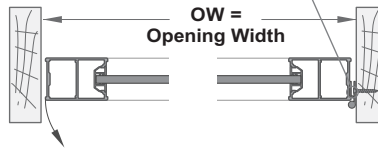

Typical Horizontal Section Single Door 3515 Frame and JC 242 Security Hinge

JC 242 Security Hinges

OW = Opening Width

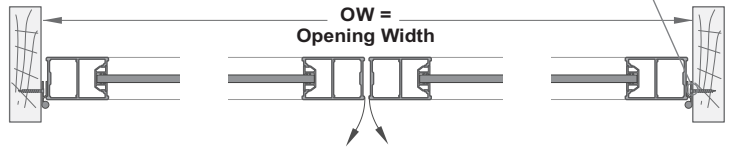

Typical Horizontal Section Double Door 3515 Frame and JC 242 Security Hinge

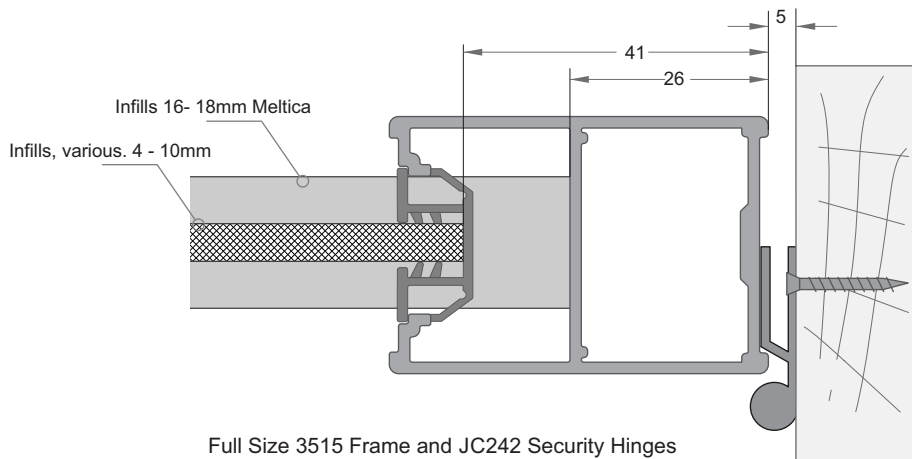

Full Size 3515 Frame and JC242 Security Hinges

350 HINGED DOORS - CUTTING CALCULATIONS

	Heights. Single or Double	Part	Formula, mm
1	Frame Height = FH	3515	OH - 6 (=FH)
2	Infill Height, (4-10mm) incl Gasket	NA	FH - 82
3	Infill Height (16-18mm) No Gasket	NA	FH - 52

	Widths. SingleDoor	Part	Formula, mm
1	Frame Width = FW	3515	OW - 10 (=FW)
2	Infill Width (4-10mm) incl Gasket	NA	FW - 82
3	Infill Width (16-18mm) No Gasket	NA	FW - 52

	Widths. DoubleDoor	Part	Formula, mm
1	Frame Width = FW	3515	OW/2 - 8 (=FW)
2	Infill Width (4-10mm) incl Gasket	NA	FW - 82
3	Infill Width (16-18mm) No Gasket	NA	FW - 52

Note : Mirror, Glass panel size imitations . Refer to page 3

Juralco 350 Systems - Bottom Roller Door, Features, Construction Details

System 2 - Bottom Roller Type

A Butted corner type, for Bottom Roller operation
A cost effective system for all architectural applications
where multiple doors are to move distances greater
than their width.

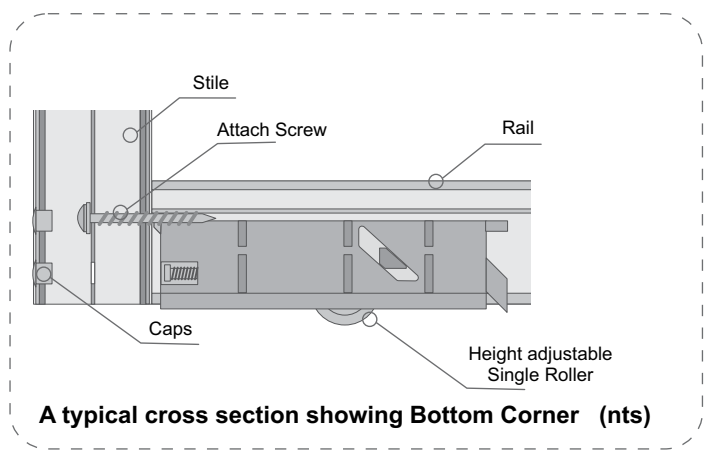
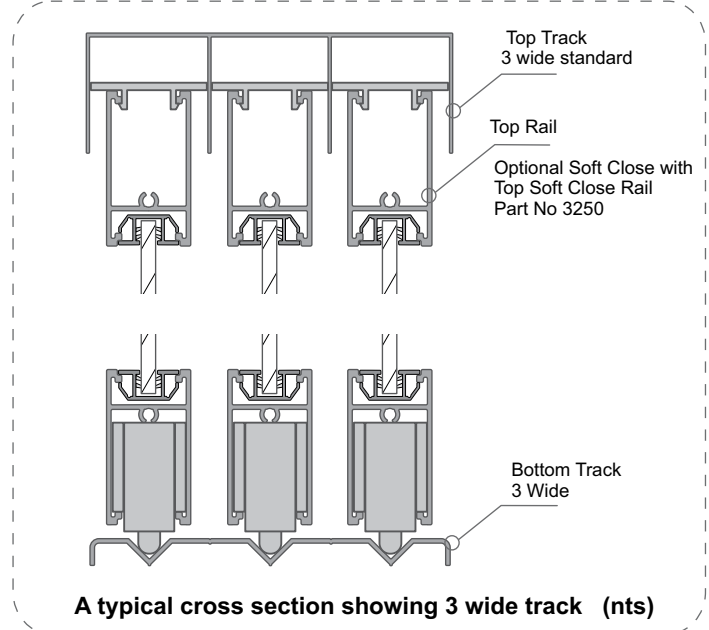
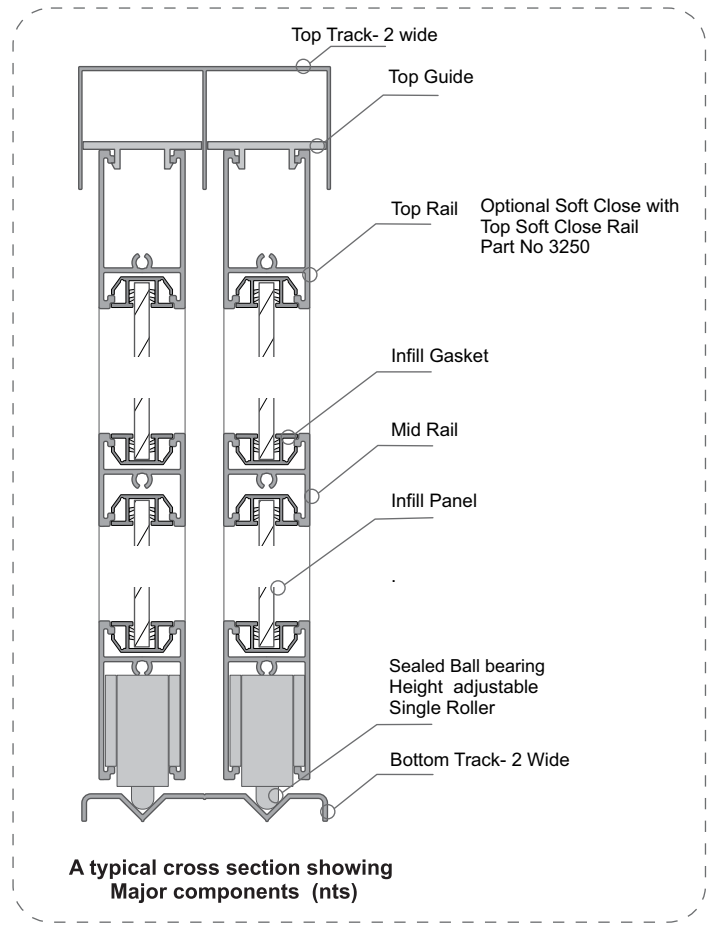
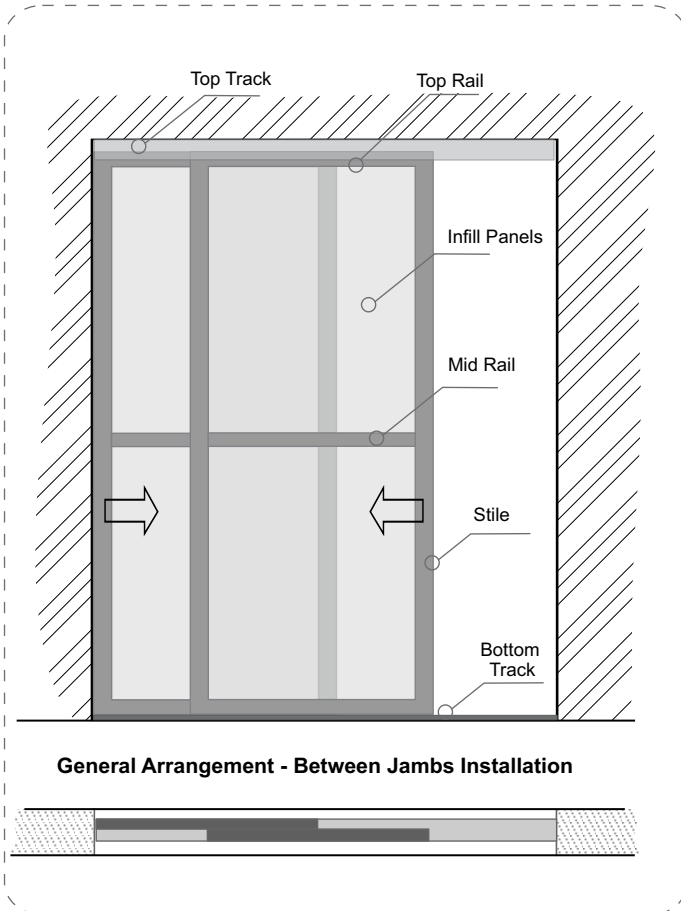

GENERAL DESCRIPTION

- Doors - Max Height 2700mm . Max width 1200mm
- Top Track install - Between Jambs mount only
- Aluminium extrusions - a range of standard and custom powder coated and anodized finishes - Contact Juralco
- Two and Three track systems, suitable for multiple doors.
- Strong stable frame with maximum corner rigidity
- Quiet , smooth operation guaranteed
- Flush Handle Hardware
- Large float for door height / floor variations
- Easy, positive, on site height adjustment.
- Optional Soft Close

INFILL TYPES

- Infill panel location - PVC co-extrusion has a solid body and flexible tongues - firmly locates infill panels in the extrusion in a stylish and minimal manner
- Glass Panels - 4 to 5mm thickness, Safety Mirror, Etchlite, Sandblasted, Applied Films.
- Plastic Panels, 4 to 5mm thickness, Polycarbonate or Acrylic Translucent
- Melteca Panels 9mm, Colours
- MDF, 9mm, Gib 10mm for Painting
- Melteca Panels 18m, Colours, Decorative stripping.

Important Note: to conform to NZS4223.3.2016 regulations vinyl backed safety mirror must have a minimum thickness of 4mm with a maximum fully framed area of 2.0m². If the wardrobe system is used as a partition between rooms annealed glass can be used with a minimum thickness of 5mm and maximum area of 0.5m² per panel

Juralco 350 Systems - Bottom Roller Door Extrusions

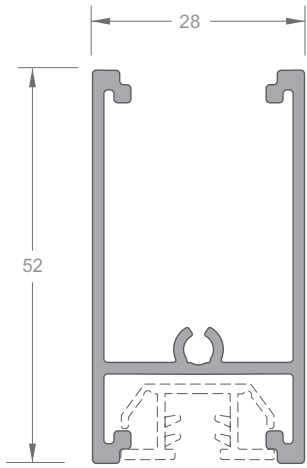

TOP or BOTTOM RAIL
Part No 3516

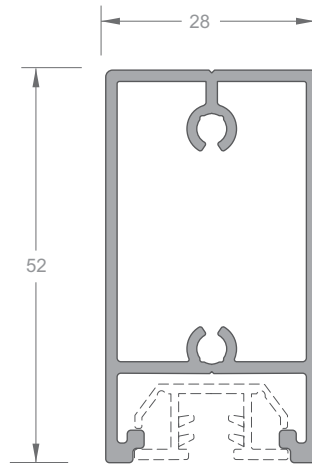

TOP SOFT CLOSE RAIL
Part No 3520

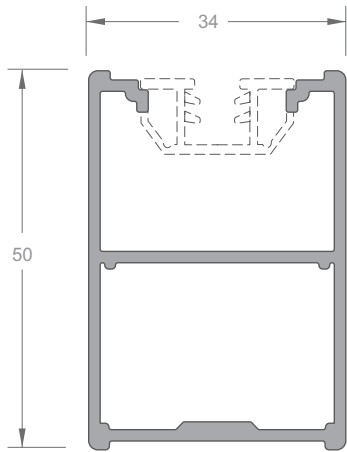

STILE
Part No 3515

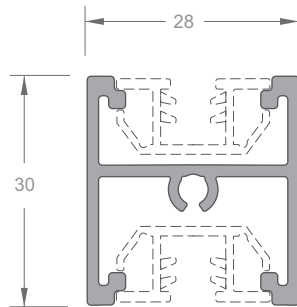

MID RAIL
Part No 3522

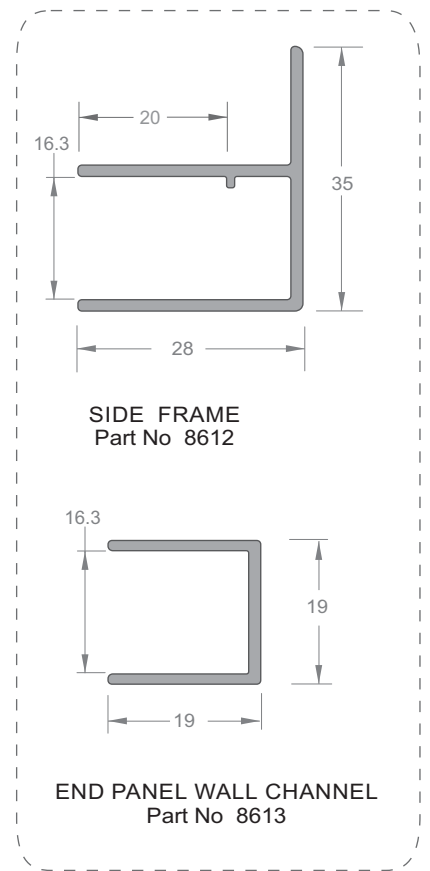

SIDE FRAME
Part No 8612

END PANEL WALL CHANNEL
Part No 8613

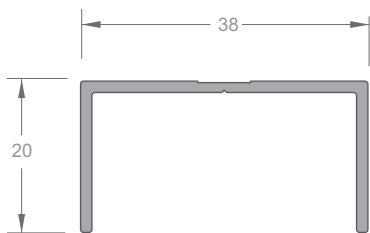

WALL CHANNEL
Part No 504

Juralco 350 Systems - Bottom Roller Door Extrusions

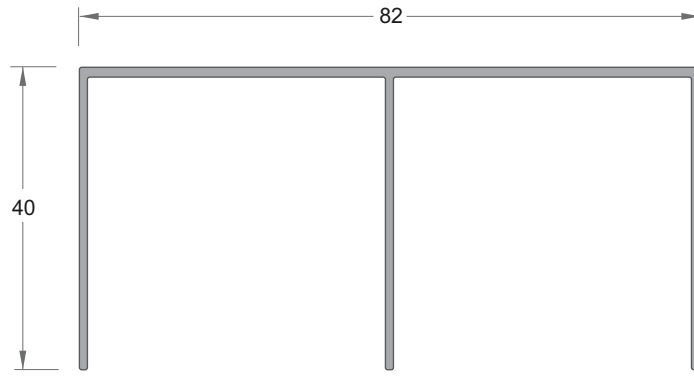

TOP GUIDE TRACK - 2 DOOR
Part No 8218

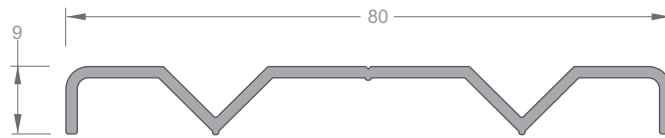

BOTTOM TRACK - 2 DOOR
Part No 3517

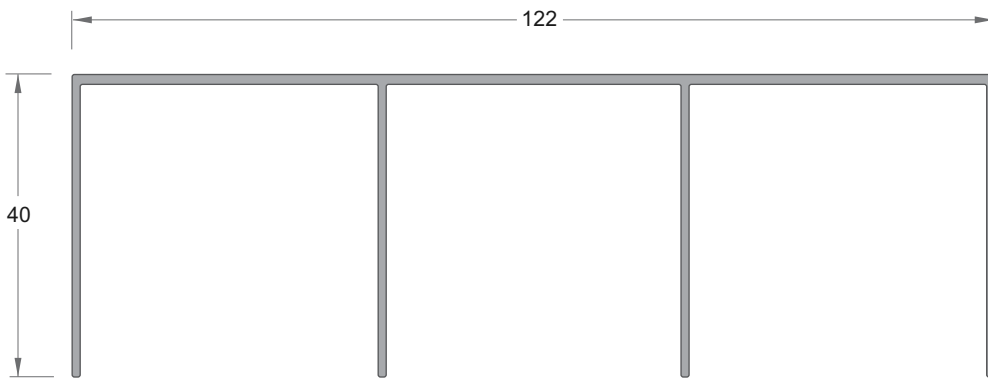

TOP GUIDE TRACK - 3 DOOR
Part No 8228

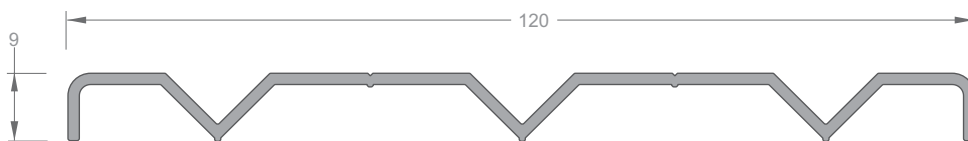

BOTTOM TRACK - 3 DOOR
Part No 3527

Juralco 350 Systems - Bottom Roller Door Components

Fastener No6 x 35
Pan Head

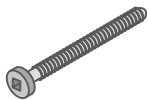

Screw Cover Cap
Part No SJ 037



Top Guide
Part No W54

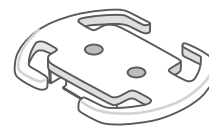

Gaskets, Inserts

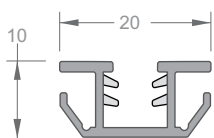

INFILL GASKET - SMALL
Panels 4mm - 5mm
Part No W51/2.6

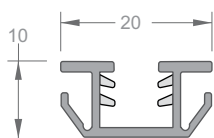

INFILL GASKET - MEDIUM
Panels 6mm - 8mm
Part No W60/2.6

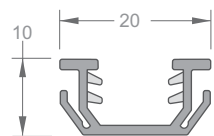

INFILL GASKET - LARGE
Panels 9mm - 10mm
Part No W55/2.6

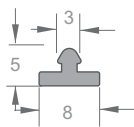

8mm INSERT
Part No 3521

Wheel Assembly
Part No W50

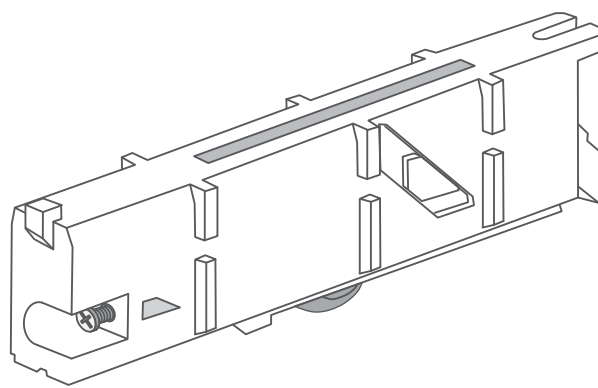

Juralco 350 Systems Bottom Roller Door - Soft Close - Components and Setout

Note - When installing the Soft Close mechanism, Top height deduction is now 29mm, not 20mm as with a normal Door

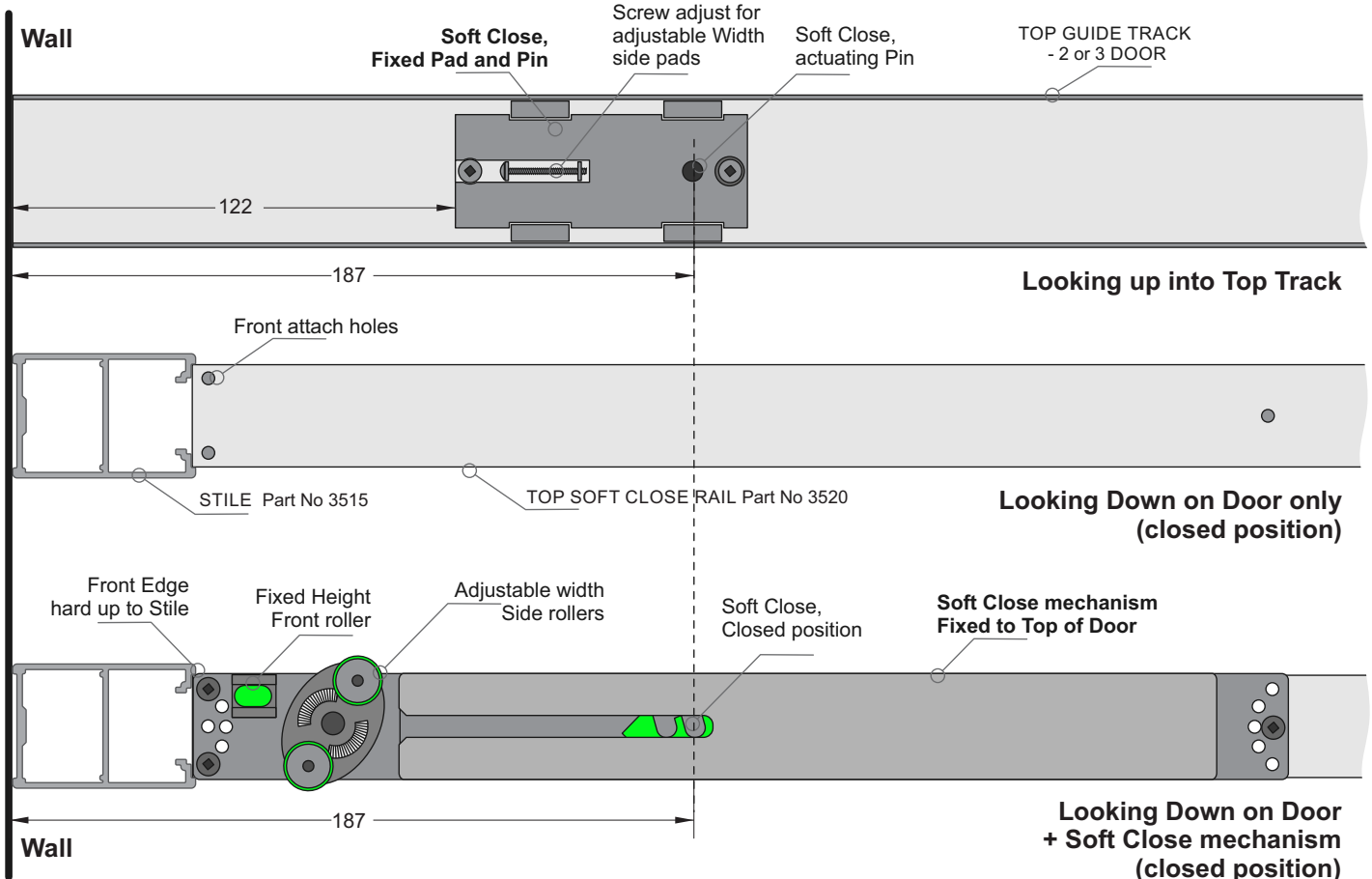
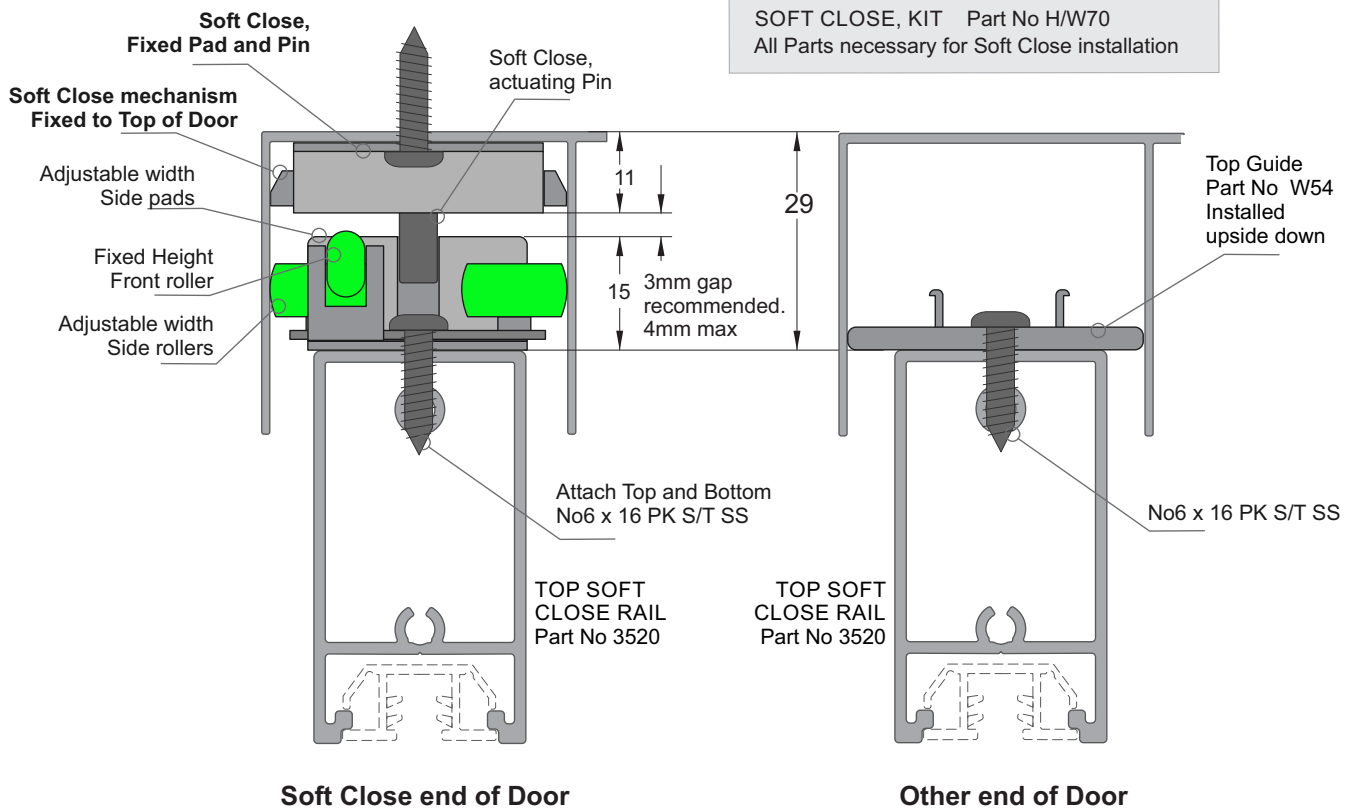

Juralco 350 Systems Bottom Roller Door, Typical Sections and Features

Typical Vertical Sections

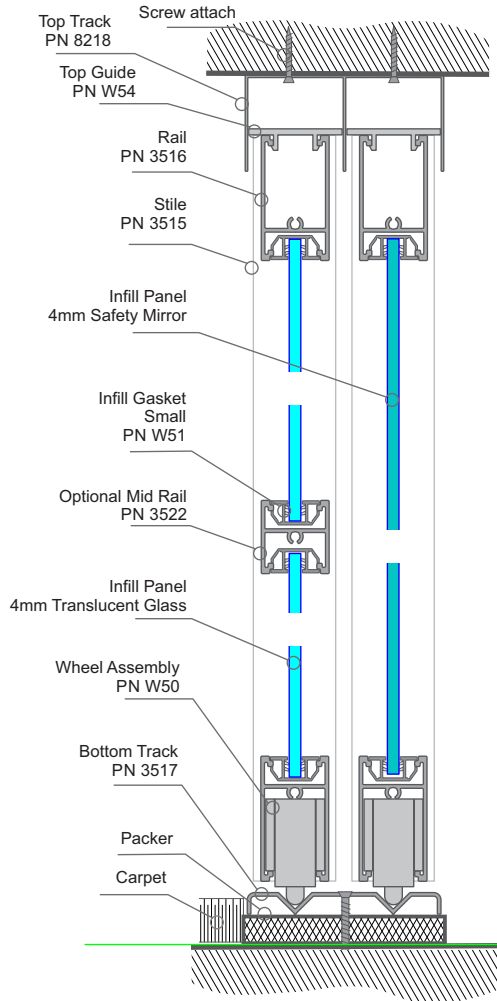

**Typical Vertical Cross Section
Twin Track, Under Jamb Mount**

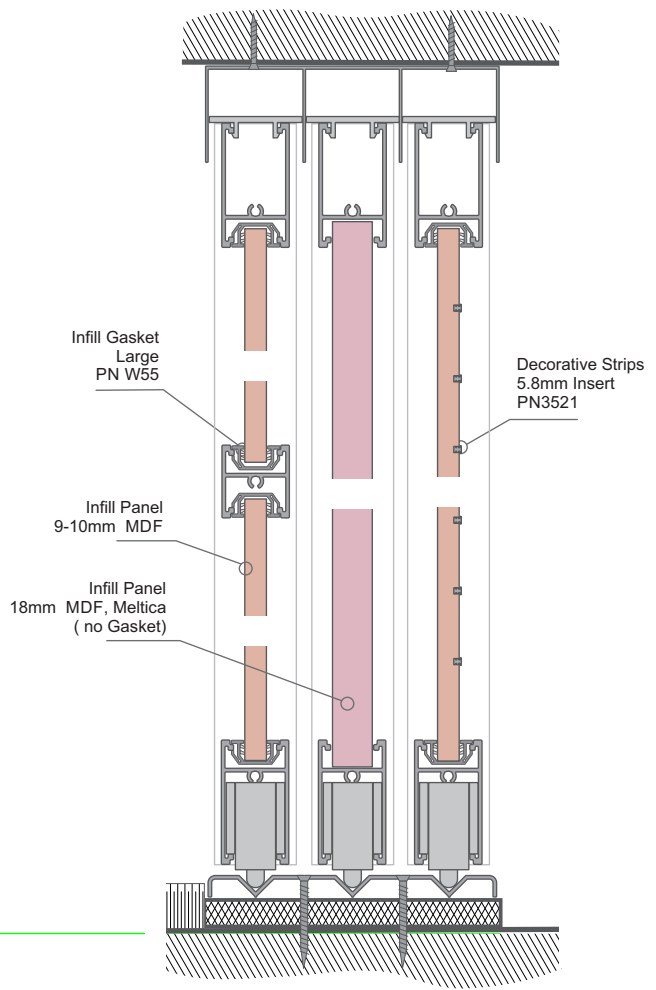

**Typical Vertical Cross Section
Triple Track, Under Jamb Mount**

Typical Horizontal Sections

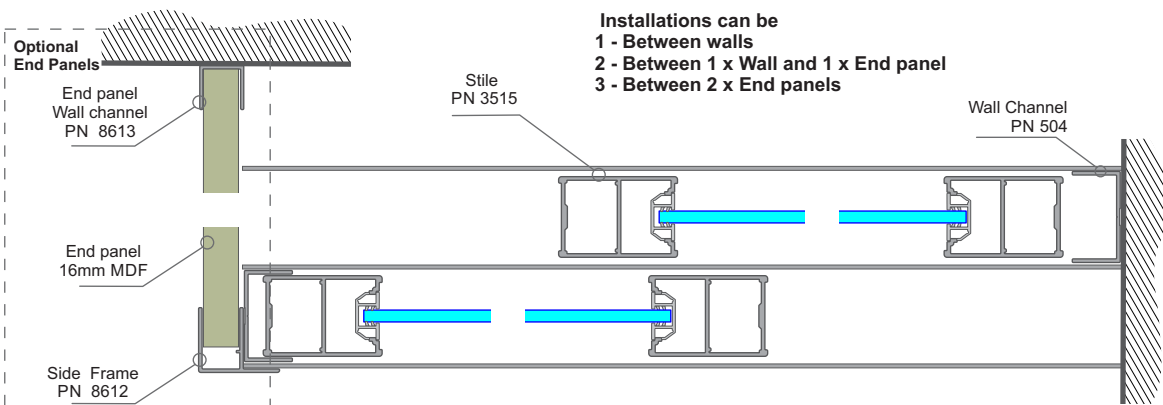

Typical Horizontal Cross Section - Twin Track Showing Optional End Panel

Juralco 350 Systems - Bottom Roller Door, Cutting and Infill Allowances

Rail Cutting Allowances

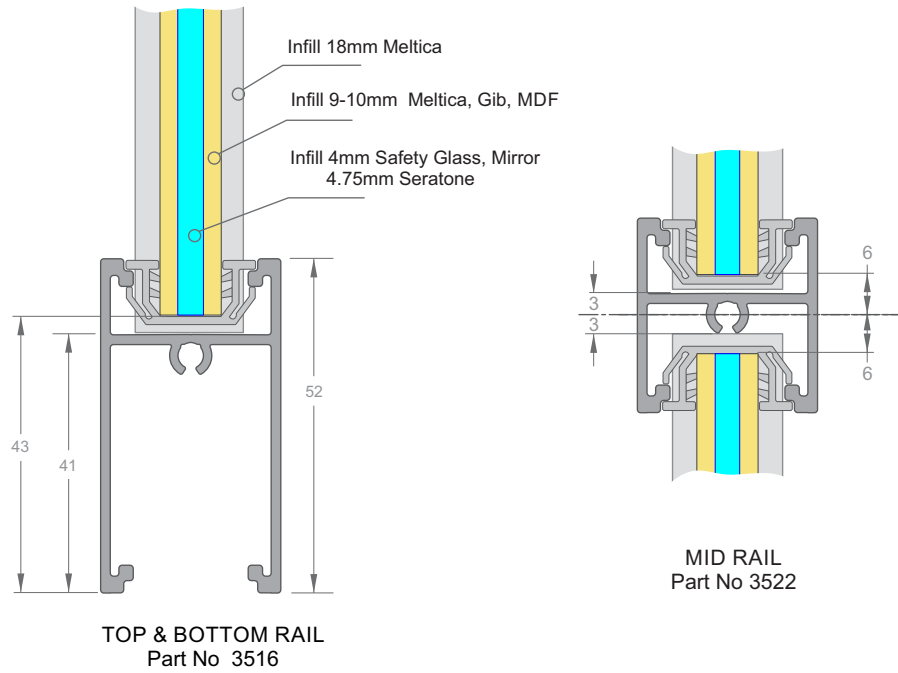

Stile Cutting Allowances

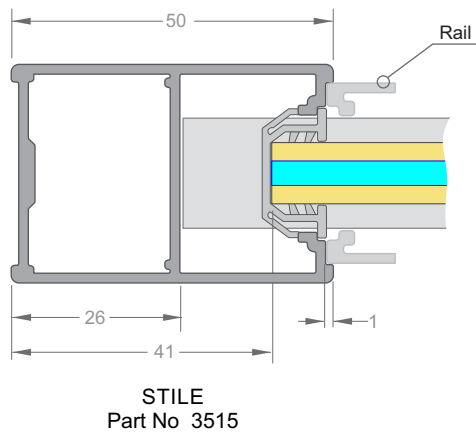

Stile Overlaps

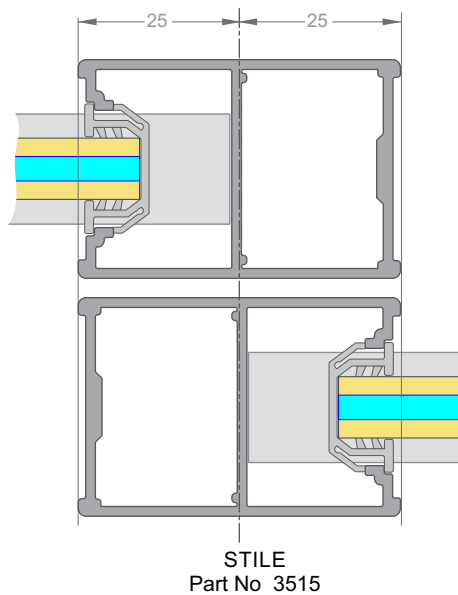

Juralco 350 Systems - Bottom Roller Cutting

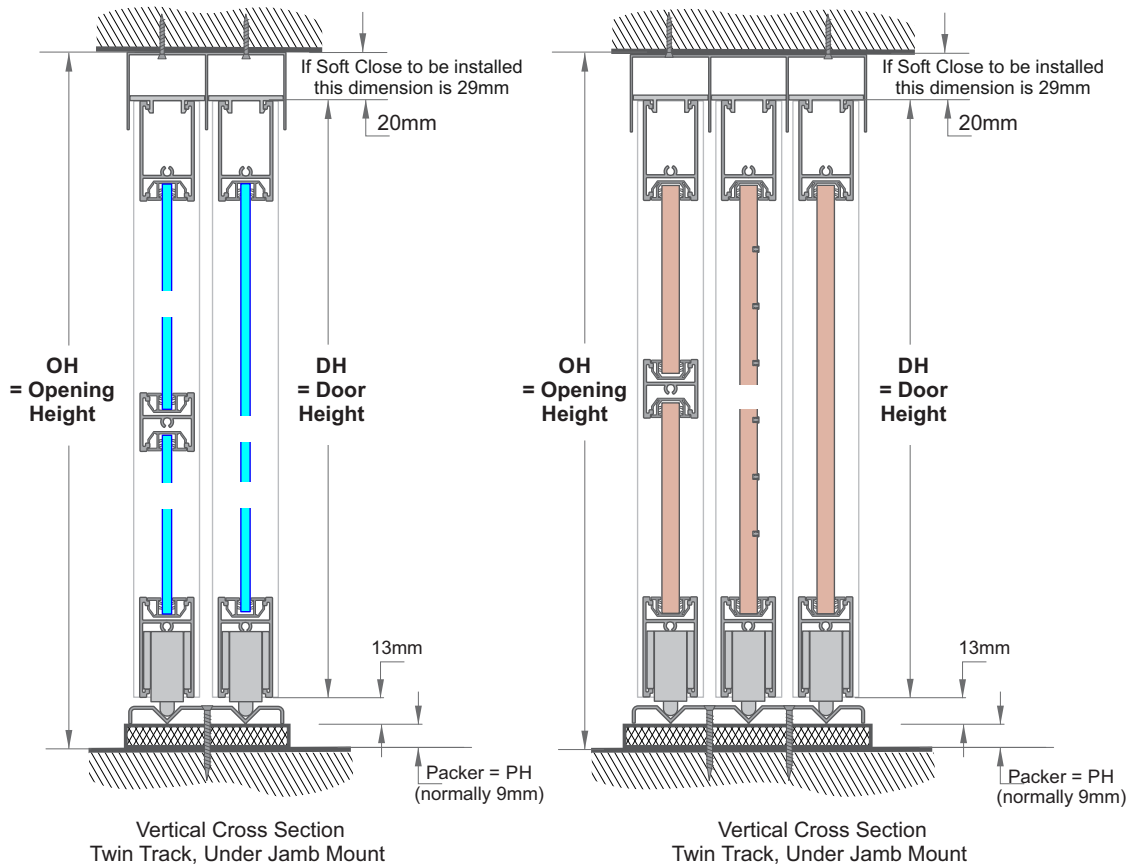

BOTTOM ROLLER DOORS - HEIGHT CUTTING FORMULA

	HEIGHT	Part	Formula in mm
1	Single Door, Height = DH		$OH - PH - 33 (= DH)$
2	Single Door, Height = DH (including Soft Close)		$OH - PH - 42 (= DH)$
3	Stiles, 90 deg ends	3515	DH
4	Infill Gasket	W51, W55	DH
5	Infills, 4mm - 10mm Glass, MDF, Meltica, Gib	NA	$DH - 86$
6	Infills, 18mm Meltica (no Gasket)	NA	$DH - 82$
7	Wall Channel (trim to architrave)	504	DH

Notes - The vertical Infill gaskets = the full height of the door.

Screw thru the gasket top / (mid) / bottom. This will lock it in place

- Soft Close components reduce the Door Height by 9mm as above

Note : Mirror, Glass panel size imitations . Refer to page 15

Juralco 350 Systems - Bottom Roller Cutting

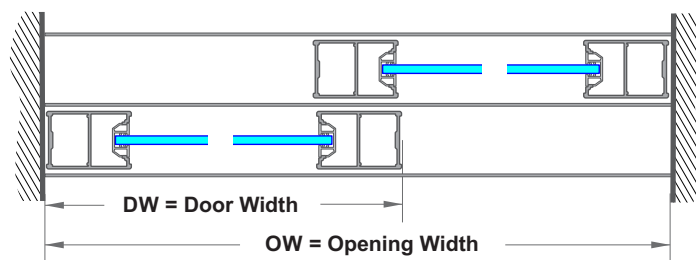

Typical Horizontal Cross Section Twin Tracks - Under Jamb Mount

DOUBLE TRACK, TWO DOORS - WIDTH CUTTING FORMULA

	WIDTHS	Part	Formula in mm
1	Top Track	8218	OW
2	Bottom Track	3517	OW
3	Single Door, Width = DW		$OW / 2 + 25 (= DW)$
4	Top, Bottom Rail	3516	DW - 98
5	Infill Gasket	W51, W55	DW - 98
6	Infills, 4mm - 10mm Glass, MDF, Meltica, Gib	NA	DW - 82
7	Infills, 18mm Meltica (no Gasket)	NA	DW - 52
8	Door, Mid Rail	3522	DW - 98

Note : Mirror, Glass panel size imitations . Refer to page 15

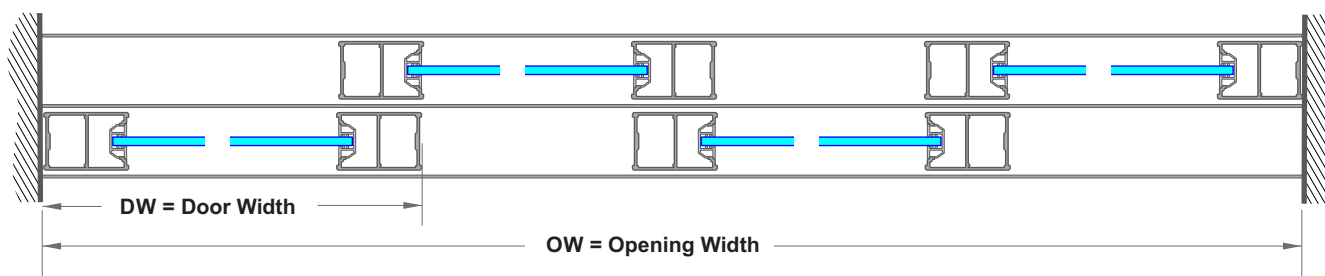

Typical Horizontal Cross Section Twin Tracks - Under Jamb Mount

DOUBLE TRACK, FOUR DOORS - WIDTH CUTTING FORMULA

	WIDTHS	Part	Formula in mm
1	Top Track	8218	OW
2	Bottom Track	3517	OW
3	Single Door, Width = DW		$OW / 4 + 38 (= DW)$
4	Top, Bottom Rail	3516	DW - 98
5	Infill Gasket	W51, W55	DW - 98
6	Infills, 4mm - 10mm Glass, MDF, Meltica, Gib	NA	DW - 82
7	Infills, 18mm Meltica (no Gasket)	NA	DW - 52
8	Door, Mid Rail	3522	DW - 98

Note : Mirror, Glass panel size imitations . Refer to page 15

Juralco 350 Systems - Bottom Roller Cutting

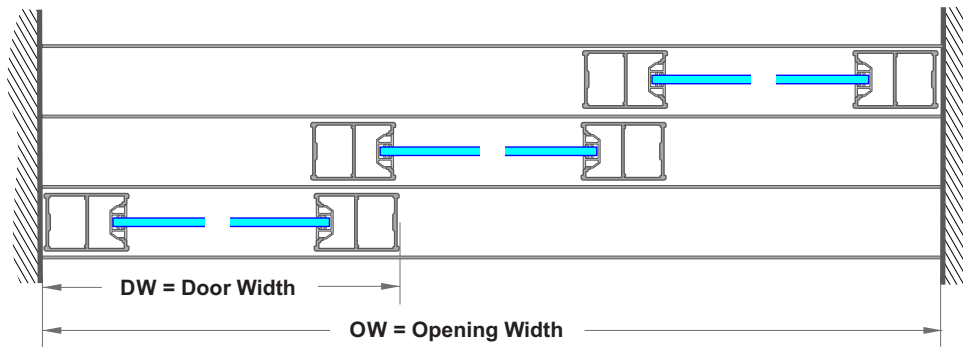

Typical Horizontal Cross Section Triple Track - Under Jamb Mount

TRIPLE TRACK, THREE DOORS - WIDTH CUTTING FORMULA

	WIDTHS	Part	Formula in mm
1	Top Track	8228	OW
2	Bottom Track	3527	OW
3	Single Door, Width = DW		$OW / 3 + 33 (= DW)$
4	Top, Bottom Rail	3516	DW - 98
5	Infill Gasket	W51, W55	DW - 98
6	Infills, 4mm - 10mm Glass, MDF, Meltica, Gib	NA	DW - 82
7	Infills, 18mm Meltica (no Gasket)	NA	DW - 52
8	Door, Mid Rail	3522	DW - 98

Note : Mirror, Glass panel size imitations . Refer to page 15

Juralco 350 Systems - Bottom Roller Cutting

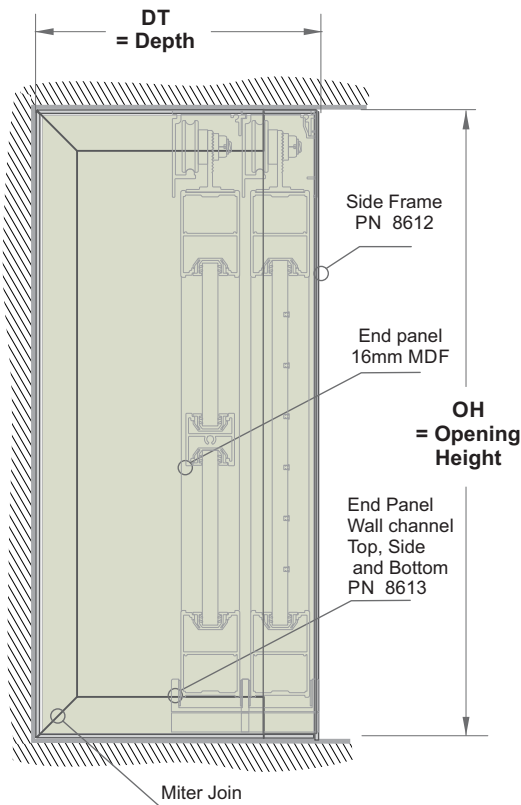

END PANELS, CUTTING FORMULA

	ITEM	PART	Formula in mm
1	Side Frame - Height	8612	OH
2	Wall Channel - Height (Miter ends)	8613	OH
3	Wall Channel - Depth (1 x Miter end)	8613	DT- 28
4	Infill - 16mm MDF - Height	NA	OH - 4
5	Infill - 16mm MDF - Depth	NA	DT- 20

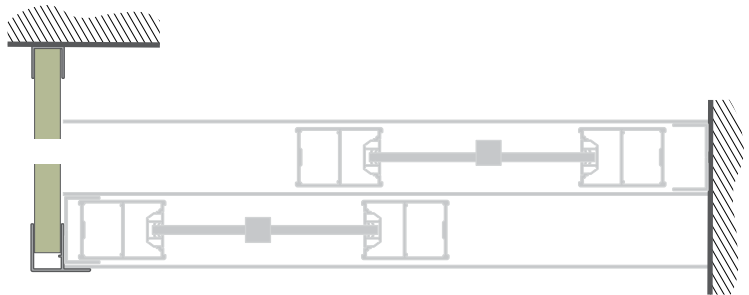

Manufacturing & Assembly procedure for Bottom Rolling Panels

- 1 - Ensure work area is clean and free from dust. Hands must be clean and free from dirt / oils.
- 2 - Inspect aluminium extrusions to ensure they are free of extrusion or surface finishing defects.
- 3 - Cut aluminium extrusions to size following the cutting instructions.
- 4 - Rout and insert handles in stiles and drill holes as per instructions.
- 5 - Cut infill gasket to size and infill to size as per cutting formula.
Run the vertical Infill gasket to the Door height as in Fig 2 below.
Fit the infill gasket to the edges of the infill by raising the infill face upwards on blocks and gently tapping with a soft mallet. The Top/mid/bottom assembly screws will then lock it in place.
- 6 - Centre and press on both stiles to infill ensuring that the handle is facing the best panel side.
- 7 - Press on top rail to infill.
- 8 - Insert wheels into each end of the bottom rail.
- 9 - Screw stiles/wheels on each side of the top and bottom rails.
- 10 - Press top guides into the top rail carefully by hand (do not use a mallet).
- 11 - Clean off all fingermarks, leave site clean and tidy.

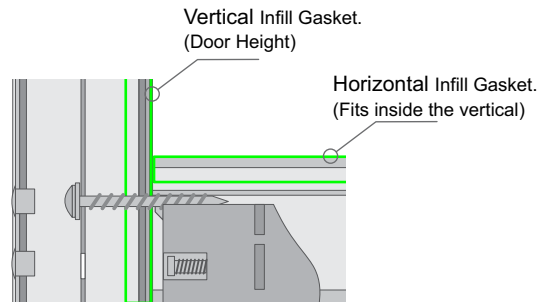
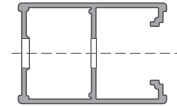
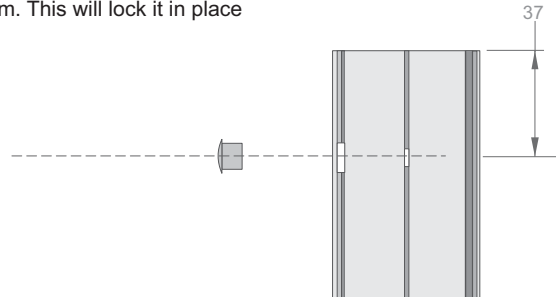
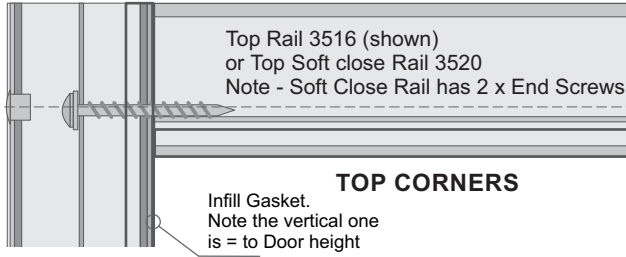

Fig 2

Juralco 350 Systems - Bottom Roller Door Machining Details

Corner Joins

Note - The vertical Infill gaskets = the full height of the door.
Screw thru the gasket top / (mid) / bottom. This will lock it in place



Stile 3515

Stile 3515

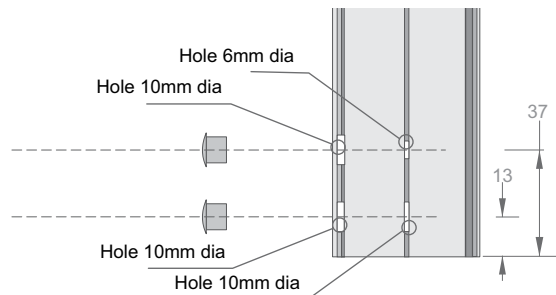
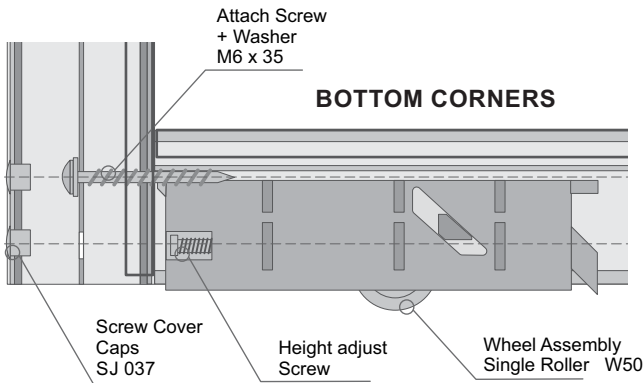

Decorative Inset

Standard - 4 x Inserts per Door

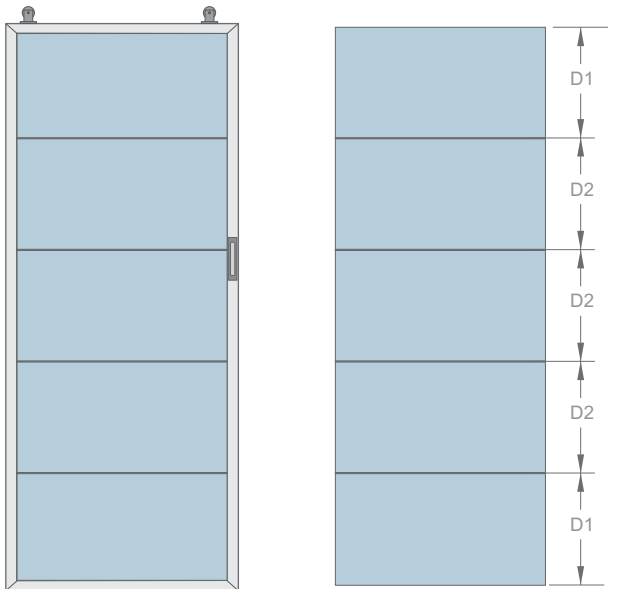

INFILL OPTIONS

- 1 - Safety Mirror 4mm
- 2 - Etchlite Glass 4mm
- 3 - MDF 9mm
- 4 - Gib 10mm
- 5 - Meltica 9mm
- 6 - Meltica 18mm (for inserts)

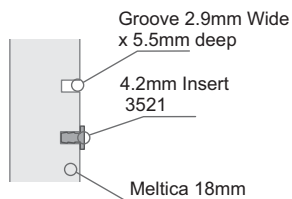

Flush Handle

Standard - 2 x Handles per Door

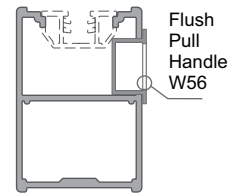
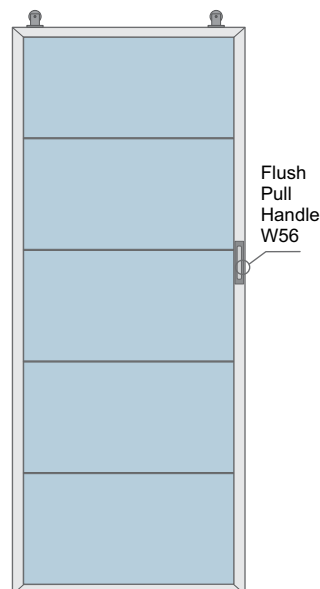

Handle in Rear Position

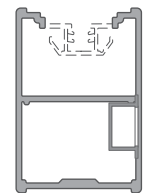

Handle in Front Position

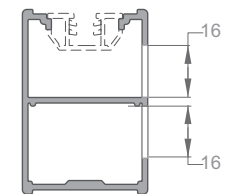

Handle Slot
16mm Wide x 85mm Deep

Architectural Series Fence and Gate System - Powder Coating Care and Maintenance

Powder Coating Installation Care

Warning re use of solvents:

- In some cases strong solvents are recommended for thinning various types of paints and also for cleaning up mastics and sealants.
- These can be harmful to the extended life of the powder coated surface, and must not be used for cleaning purposes.
- It is important to note that the damage will not be visible immediately and may take up to 12 months to develop.

If paint splashes or sealants and mastics need to be removed then the following may be safely used:
Methylated Spirits, Ethyl Alcohol, Isopropanol or preferably a mild detergent in warm water.

Joinery Protection during Installation:

All the activity on a construction site means that your powder coated items may get knocked or scratched, splattered with mortar, plaster, textured coating or paint during the later stages of construction.

Please ensure that all powder coated articles are masked or covered at this time. It is far easier to prevent accidents than to try and correct them. Should your joinery receive mortar or paint splashes see that these are removed before cure and follow the instructions contained in this brochure.

Typical sticker used to warn other trades of the need to protect and mask off powder coated joinery (applies to anodised joinery also)

"IMPORTANT ALL TRADES"
This valuable aluminium joinery will suffer permanent damage from: plaster, mortar and paint splashes - Protect if splashes occur - Immediately wash down joinery with water or meths - Do not allow splashes to harden! ~ Do not use solvents!
- Do not remove this label until final clean completed.

This photograph displays damage that has occurred on site, post installation. The photo of the masked joinery displays clear signs of damage that could have occurred were it not masked. Please ensure that your joinery is protected right through the entire construction process.



Powder Coating Maintenance

External - Maintenance Program:

To extend the life of external powder coated articles and to comply with warranty requirements for powder coated aluminium joinery, a simple, regular maintenance program must be implemented.

The effects of ultra violet light, atmospheric pollution, dirt, grime and airborne salt deposits will all accumulate over time and must be removed or surface staining and weathering will occur, leading to an unsightly appearance.

For external coatings, cleaning should take place every six months. In areas where pollutants are more prevalent, such as beachfront houses and industrial or geothermal areas, then a cleaning program should be carried out on a more frequent basis ie. every one to three months.

Fences or Balustrades in close proximity to swimming pools must be washed down every six months, to clean off chlorine and salt deposits.

Cleaning your powder coating:

1. Carefully remove any loose surface deposits with a wet sponge.
2. Use a soft brush (non abrasive) and a mild household detergent (do not use solvents) in warm water, remove dust, salt and other deposits.
3. Rinse off with clean fresh water.



Restoring weathered or scratched surfaces:

Repair of Scuffed or Scratched surfaces
Dulux Spray Cans are available in all colour card colours.

Repair of Small Scratches or Chips.
Dulux Dabsticks are ideally suited for the repair of small scratches.
Dabsticks may not be available in all colour card colours.

Repair of Weathered areas .
Dulux Gloss Up is a light to medium cutting cream ideally suited for gloss restoration and has been specifically designed for this purpose.
Gloss Up contains no waxes or silicone and is a one step system.



Contact Dulux Powder Coatings , ph 0064 9 441 8244