

INSTALLATION INSTRUCTIONS

iQ Toro SC iQ Granit SD

April 2012

CONDITIONS AND REQUIREMENTS

- The subfloor must be clean, dry and free from cracks. Dust and contaminants that could prevent adhesion, such as patches of paint, oil, etc., must be removed. Note that asphalt, oil spillage, impregnation agents, pen marks, etc., can cause discoloration. Damp proofing to be carried out according to local building standards. Where required an effective damp proof membrane must be incorporated in the subfloor. Check for dampness in ground supported floors, floors above boiler rooms, floors with underfloor heating or containing high temperature pipework etc.

- When installing this product on concrete subfloors that do not include damp-proofing, the moisture content measured in terms of relative humidity must not be higher than 85% (in UK and Ireland 75% according to BS 8203). Or less than 2% with CM (Carbide Method)

PREPARATION

- Dust and loose particles must be thoroughly removed. Highly absorbent or variably absorbent substrates should be sealed with suitable primer. The primed surface must be completely dry before laying commences.
- When applying smoothing compounds, use compounds that meet the minimum requirements in the building standards. NOTE: Discolouration can occur when using two-parts polyester compounds if they are mixed incorrectly and/or insufficiently. Do not mix directly on the substrate.
- Use only a lead pencil for marking. Note that any marks made with felt-tipped pens, permanent and non permanent ink markers, ball point pens etc. can cause discoloration due to migration.
- If material from several rolls is used, they should have the same manufacturing serial numbers and be used in consecutive order.

INSTALLATION GENERAL

- If local building standards or regulations states any special installation technique or has technical advises for this type of products not corresponding to this instruction, our instructions are automatically subordinated and should only be taken in consideration as guidelines.
- Installation should be carried out at room temperature between 18°C to 26°C. Subfloor temperature must be at least 15°C. The relative air humidity in the premises should be 30-60%. Maintain same temperature and humidity for at least 72 hours after installation.
- Rub the face surface down thoroughly to ensure that the floor covering makes good contact with the adhesive and that all air is expelled. Make sure that the tool used for rubbing down the floor covering does not scratch the

- Where pipes are laid in the floor they should be arranged so that the flooring material is not continuously subjected to a temperature above 27°C, otherwise there may be discoloration and/or other alterations of the material.
- Extra special care must be taken regarding installations on surfaces where significant temperature changes can be expected, for example, floors exposed to strong sunlight, as adhesion strength and subfloor treatment may be heavily stressed.
- Floor boards and similar substrates should have a moisture content of max 8% (equivalent to 40% RH at +20°C), so that any subsequent movements cannot cause damage.
- **Note: These products are not approved for use in wet areas.**

Tiles: If tiles from several boxes is used, they should have the same manufacturing serial numbers and be used in consecutive order. Boxes from different pallets must not be mixed. Pallets shall be installed in sequence.

- Prior to laying, allow the material, adhesive and subfloor to reach room temperature, i.e. a temperature of at least 18°C. The relative air humidity should be 30-60%. **Rolls must be stored indoors.**

Tiles: Prior to laying, allow the boxes of tiles, adhesive and subfloor to reach room temperature for 48 hours. I.e. a temperature of at least 18°C. The relative air humidity should be 30-60%. **Make sure the boxes of tiles are piled not more than five, flat and parallel. Boxes must be stored indoors.**

- **The rolls should be stored upright.** Any faults in the material must be reported immediately to your nearest sales office. Always quote the colour and roll numbers, which are stated on the label.

surface. A broom is not suitable for this purpose. Use a floor roller (approx. 65 kg) and roll crosswise over the floor.

- **Always be careful when cutting, making grooves etc., that the copper strips are not damaged, to ensure that all sections of the surface are connected to earth after installation.**
- Most commonly, the copper strips will be connected to the normal electrical earthing network of the building. In highly ESD-sensitive areas, the copper strips will be connected to a separate earthing system provided by the end user. **In all cases the connection to earth must comply with local electrical and building codes and regulations.**

INSTALLATION SHEETS

- The earth connection is achieved with the copper strips.
- Cut the sheets to length and, if possible, lay them out to acclimatise prior to laying. This is particularly important for longer lengths.
- **Sheets must be installed so that colour differences are avoided. Reverse sheets whenever possible.**

- The sheets are fully adhered with an adhesive approved for Tarkett's homogeneous vinyl sheet. **See the adhesive manufacturer's instruction regarding coverage, open time etc.** The assembly time depends on the type of substrate, its absorbency, the temperature and air humidity in the premises. **On top of the copper strips, apply a high quality conductive adhesive with permanent conductive properties using a brush.**

Earth connection sheets

Sheets < 10 metres:

Only use the copper strip at one of the short ends.

Sheets 10 - 20 metres:

A copper strip is placed crossways under the sheets, approx. 200 mm from the short ends. A 100 cm copper strip is placed lengthways under transversal joints.

Sheets > 20 metres:

Apply copper strips crossways at short ends and at every 20 meter. A 100 cm copper strip is placed lengthways under transversal joints.

General recommendation for earth connection sheets:

The distance from any randomly chosen point on the installed floor to a copper strip must not exceed 10 metres.

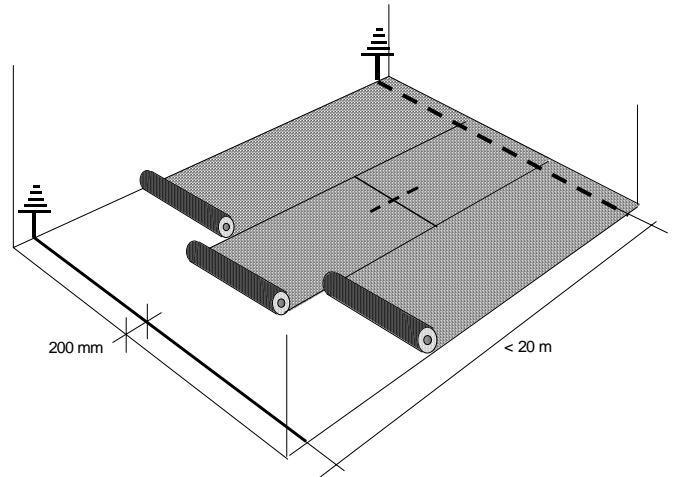

INSTALLATION TILES

- The earth connection is achieved with the copper strips.
- **The tiles are fully adhered with a high quality conductive adhesive with permanent conductive properties. See the adhesive manufacturer's instruction regarding coverage, open time etc.** The assembly time depends on the type of substrate, its absorbency, the temperature and air humidity in the premises.
- Tiles could be installed in the same direction or in a checkerboard pattern.

- Before starting installation, determine the method of laying taking into account the shape of the room and the design to be laid. Installation should start from the middle of the room and be finish along the walls.
- When installing on access flooring systems separate earth connection is not normally required, as this is achieved by the adhesive and the metal construction. Advise concerning conductivity should be taken from the manufacturer of the access flooring system

Earth connection tiles

The tiles are connected to earth with the system of conductive adhesive and underlying copper strips. The earth connection is provided with copper strips across the shorter dimension of the room, every 20 m and connected to earth.

General recommendation for earth connection sheets:

The distance from any randomly chosen point on the installed floor to a copper strip must not exceed 10 metres.

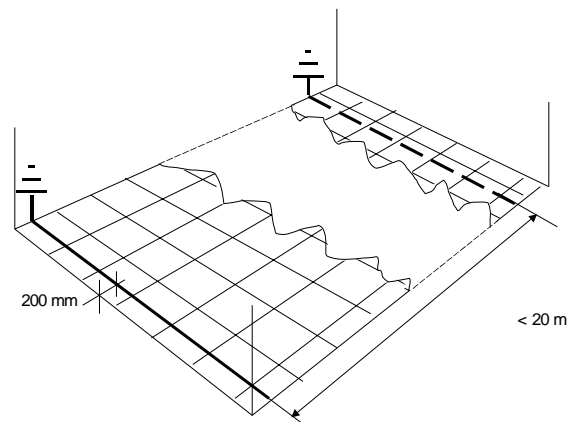

WELDING

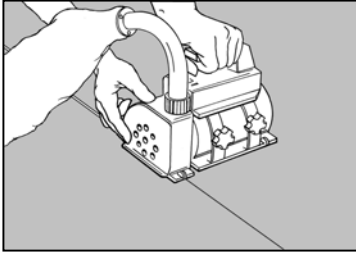

The sheets are heat welded. Do not weld until the adhesive has bonded completely. The joints are chamfered or grooved to about $\frac{3}{4}$ of the thickness using a hand grooving tool or machine prior to welding.

Extra special care must be taken so that copper strips not are damaged during chamfering /grooving.

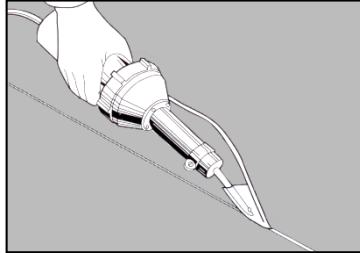

Weld with hot-air and Tarkett Speed Welding Nozzle. Carry out a test welding on a left-over piece before commencing work, to adjust speed and temperature

TRIMMING

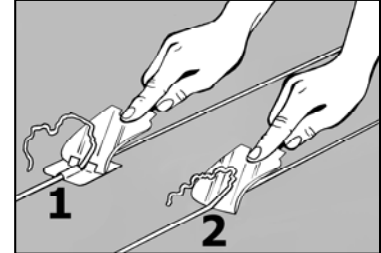

CAUTION: Welded seams must cool to room temperature before trimming. Start trimming where you began welding. All trimming of welding thread is recommended in two steps: rough and fine trimming.

INSPECTION

- The work must be completed with an inspection. Ensure that the newly laid flooring is free from adhesive residues and that the bond is consistent with no bubbles.

GENERAL

- This information is subject to change due to continuous improvement.

FOR THE BEST RESULTS

- Make sure all specifications and instructions are followed carefully.
- Use only adhesives recommended by adhesive manufacturer.
- Contact your Tarkett representative if unsure about any part of the installation.