

CROSS SECTION

Date 26.01.18 Scale 1:2

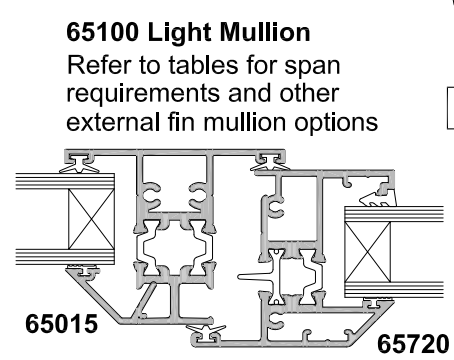

SECTION B-B

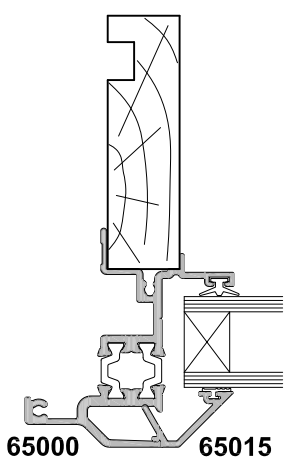
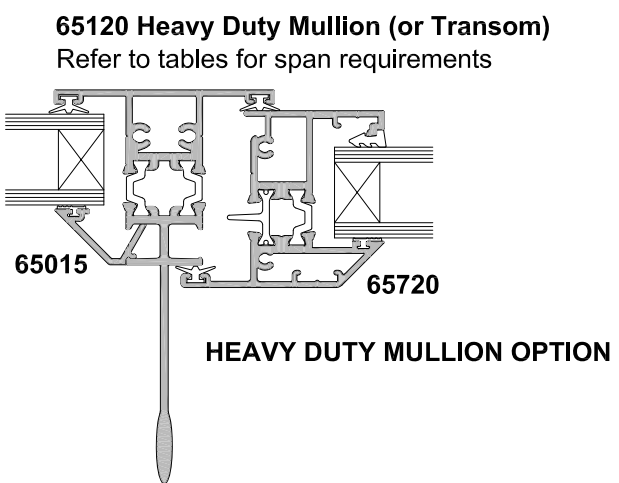
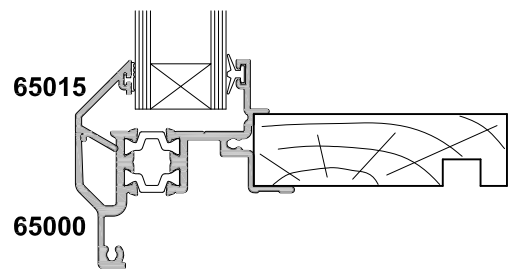
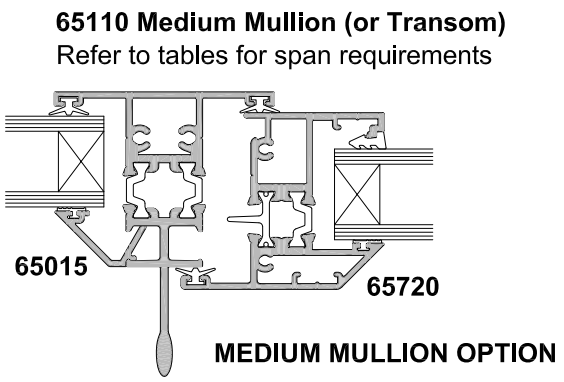
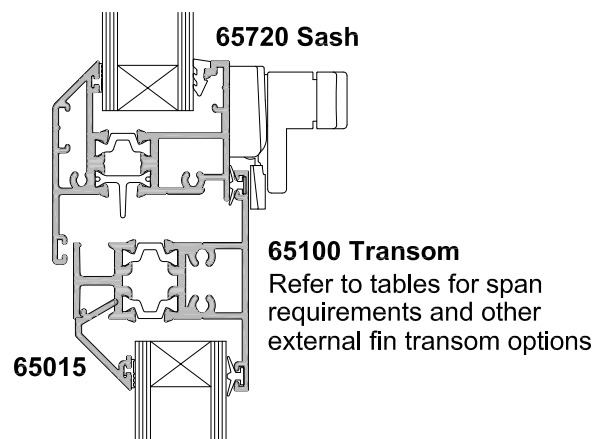
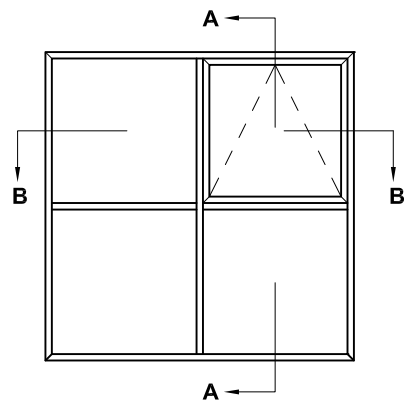
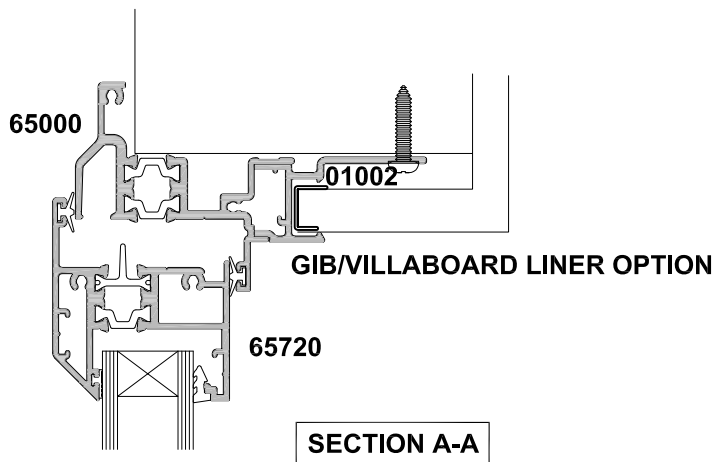
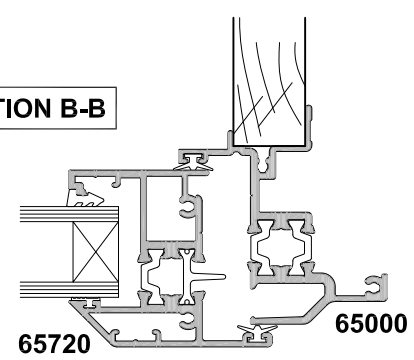

CROSS SECTION

Date 26.01.18 Scale 1:2

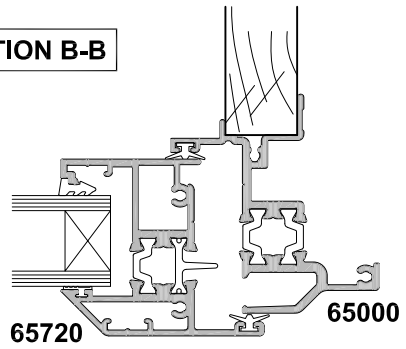
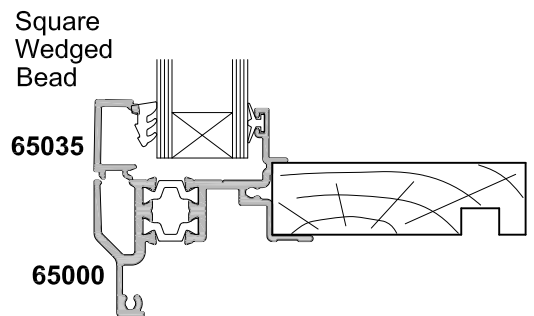
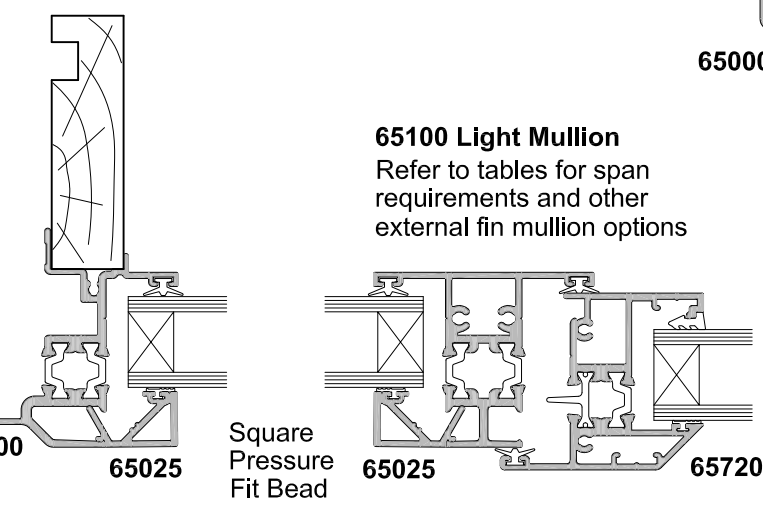
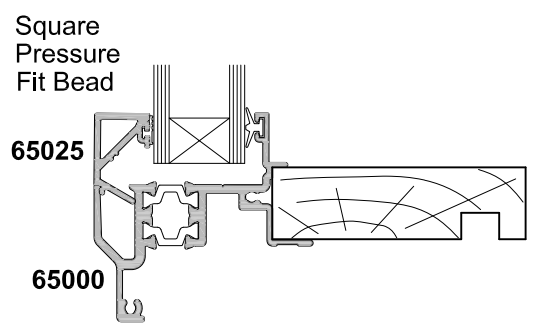
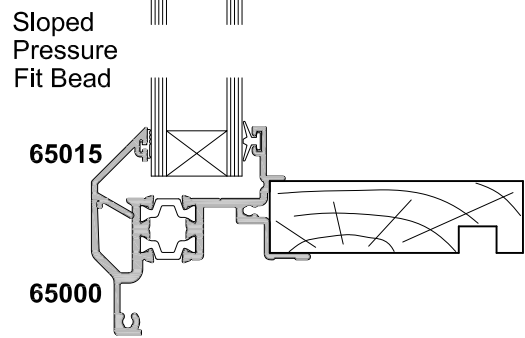
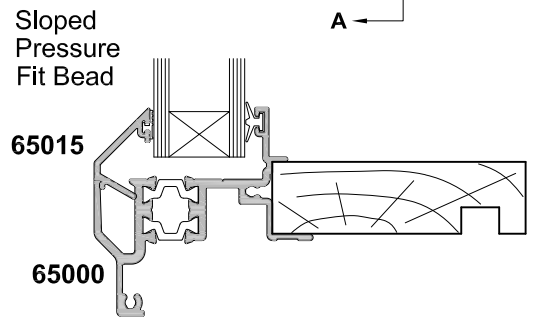
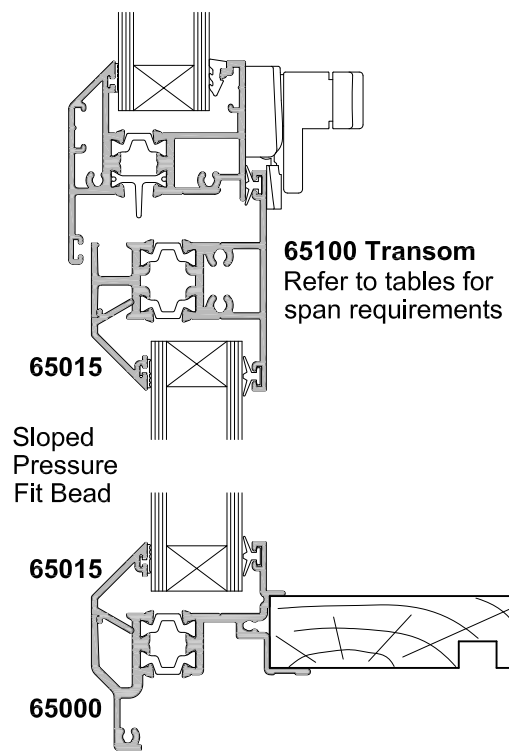
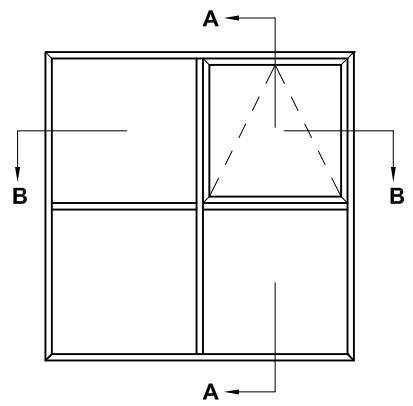
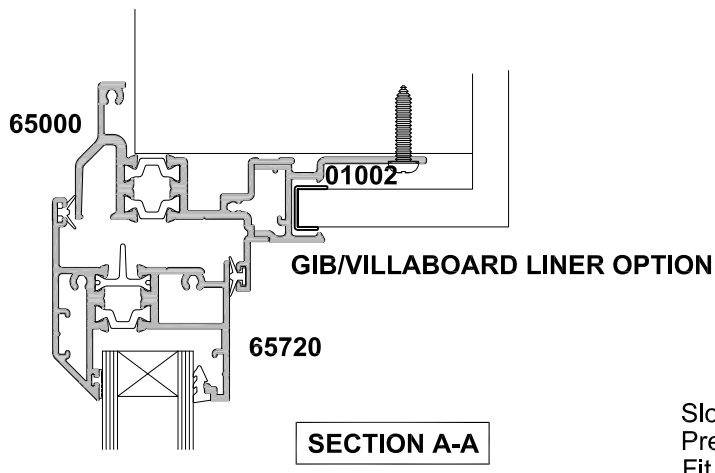

CROSS SECTION

Date 26.01.18 Scale 1:2

