

I BUILT™ CORECLAD™

CORECLAD™ DESIGN AND INSTALL GUIDE

September 2023

CoreClad textured, ACQ treated plywood cladding offers superior strength, durability and reliability. With sheets up to 3 metres long and no requirement to retreat cut ends, CoreClad is fast and easy to install.

CORECLAD™ PRIMED AND NATURAL



Contents

General	3
Purpose	3
Important documents	3
Skills required	3
For more help	3
For our warranty	3
Specification table	3
ACQ Treatment - treated to the core	3
IBuilt CoreClad Cladding System	4
Description	4
Certifications & approvals held by New Zealand Wood Products Limited	4
Scope and limitations of use	4
Scarf Joint	4
Design Steps	5
Primary structure	5
Wall underlays	5
Direct fixed or cavity construction	5
Ground clearances	5
Fixings	5
Configuration for horizontal joints	5
Flashings	5
Windows and doors	5
Coating	5
External structures	5
Documentation	5
Commonly used installation details	5
Installation	6
Key documents for referencing	6
Primary structure	6
Wall underlays	6
Cavity construction	6
Moisture content	6
Layout	6
Flashings	6
Install CoreClad	6
Fixings	6
Windows and doors	6
Quality check	6
Coating	7
Coating Selection	7
Colour Selection	7
Coating Options	7
Preparation	7
Application	7
Face Checking	8
Health & Safety, Storage & Handling	8
Care and maintenance	8
Framing	9
Sheet Profiles	10
Installation Details Direct Fixed	11
Installation Details Cavity Construction	14

General

Purpose

This guide will help correctly design, specify and install IBuilt CoreClad.

Important documents

This document must be read in conjunction with

- The IBuilt CoreClad pass™ (refer to www.ibuilt.co.nz).
- MBIE [January 2017] Acceptable Solutions and Verification Methods for New Zealand Building Code (NZ Building Code) Clause E2 External Moisture (refer to www.building.govt.nz).
- Department of Building and Housing (DBH) June 2006. Constructing Cavities for Wall Claddings (refer to www.building.govt.nz).
- BRANZ Bulletin BU468 [December 2005] Fixing Timber Weatherboards (refer to www.branz.co.nz).
- BRANZ [May 2015] Good Practice Guide: Timber Cladding (refer to www.branz.co.nz).
- BRANZ Bulletin BU582 [April 2015] Structurally Fixed Cavity Battens (refer to www.branz.co.nz).

Skills required

This guide is suitable for use by licensed building practitioners (or deemed practitioners) licensed to the relevant class.

For more help

Technical assistance is available at enquiries@nzwoodproducts.co.nz

For our warranty



Refer to www.ibuilt.co.nz

Specification table

Edge profile	Shiplap
Surface finish	Textured or Groove150 (textured with grooves at 150mm centres)
Panel length (mm)	2440, 2745*, 3050* (* Scarf jointed)
Panel width/cover (mm)	1200 (Cover), 1220 (Sheet)
Panel thickness (mm)	12
Channel dimension (Groove150)	9mm wide, 5mm deep, 150mm centres
Face/back grade	SD
Veneer species	Hoop Pine & Klinkii Pine (from sustainable managed plantation forestry)
Weight	23kg (2440mm), 26kg (2745mm), 29kg (3050mm)
Treatment	H3.2 ACQ veneer treated (Alkaline Copper Quaternary)
Bond	Type A structural marine bond
Fixings and Flashings	Must be Stainless Steel. PVC flashings can be used.
Finish	Natural or primed
Primer (CoreClad Primed)	Premium, waterbased, 100% acrylic primer (low sheen, dry film thickness 50 microns).

*A scarf joint is used to manufacture 2745mm and 3050mm length sheets.

ACQ Treatment - treated to the core

Each veneer of CoreClad is pressure treated with Alkaline Copper Quaternary (ACQ), a water-based preservative that is free of arsenic and chromium. It is treated to meet hazard class H3.2. (NZS 3640) and H3 (AS/NZS 1604).

ACQ is formed when the components of copper oxide and quaternary ammonium compounds are combined, becoming effective in protecting timber against fungal decay, borers, and termites.

ACQ contains higher levels of copper than other preservatives, which means it can be more corrosive to metals. Stainless steel fixings and stainless steel or PVC flashings must be used to minimise the possibility of bi-metallic corrosion.

IBuilt CoreClad™ Cladding System

Description

IBuilt CoreClad panels are manufactured from both Hoop Pine & Klinkii Pine, which have been grown from sustainably managed plantation forests.

Individual veneers are ACQ treated to meet hazard class H3.2 and then manufactured into plywood sheets by bonding the treated veneers with a Type A structural marine bond. The plywood sheets are machined, band sawn, grooved (if required) and ship-lapped to form the finished cladding panel.

The manufacture of IBuilt CoreClad is third party certified by EWPA to meet AS/NZS 2269:2012-Plywood Structural Standard.

IBuilt CoreClad panels are supplied Grade S-D, F14 in the following dimensions:

- Sheet thickness (mm) 12
- Sheet length (mm) 2440, 2745*, 3050* *Note: 2745mm & 3050mm
- Sheet width 1200mm (cover), 1220 (overall). Sheets are scarf jointed.
- Sheets available as Groove150 or Textured, with a natural or primed finish.



Certifications & approvals held by New Zealand Wood Products Limited

EWPA Product Certification Scheme,
Mill Number 916 AS/NZS 2269, 8/01/2019



Scope and limitations of use

For scope and limitations refer to IBuilt CoreClad pass™.

<http://nzwoodproducts.co.nz/products/details/ibuilt-coreclad/26/>

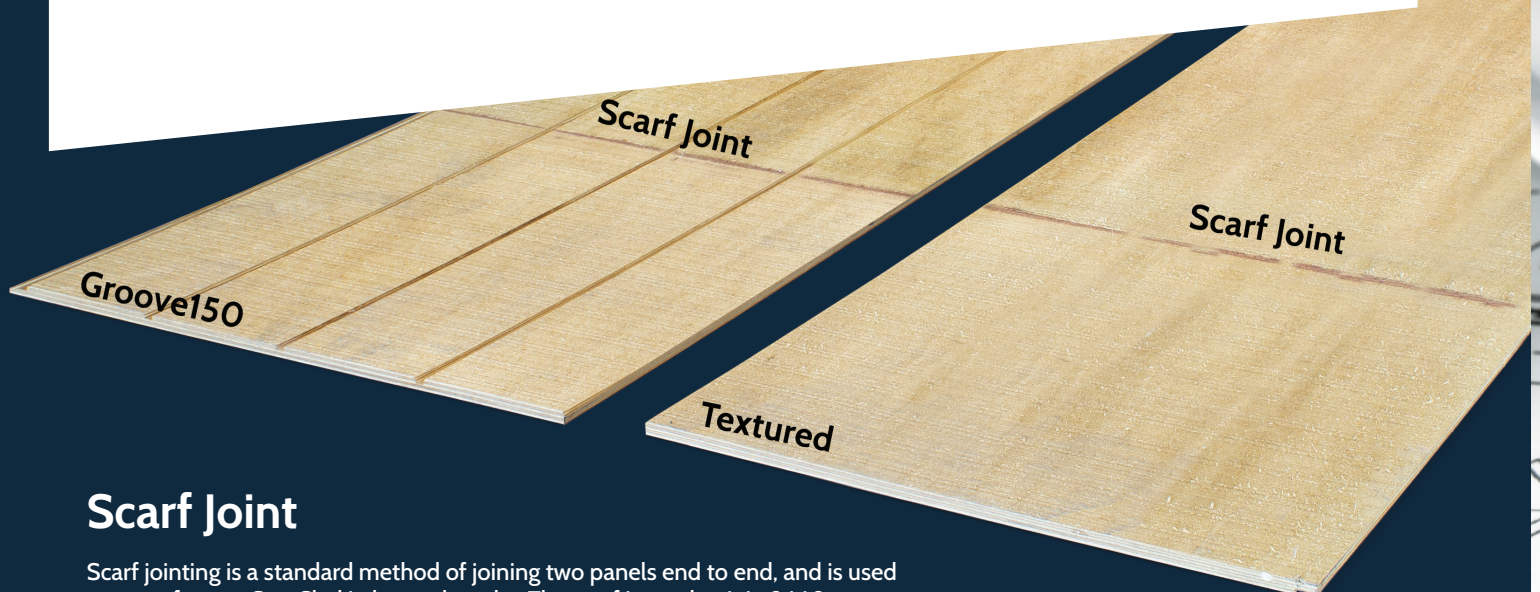

Scarf Joint

Scarf jointing is a standard method of joining two panels end to end, and is used to manufacture CoreClad in longer lengths. The scarf is used to join 2440mm long sheets with either a 300 or 600mm extension to produce 2745 or 3050mm length sheets.

The CoreClad scarf joint is fabricated in accordance with AS/NZS 2269 with a 1 in 8 slope and has the same bond durability and quality as the plywood.

On the natural sheet, the scarf joint has a visible glue line going across the panel and the two sections may have colour differences.

Design Steps

Primary structure

The primary structure must be designed:

- In accordance with NZS 3604:2011 section 2 for timber framing

Studs should be maximum 600mm centres for timber construction.

Where the primary structure is existing, the designer and installer should ensure themselves that it is suitable for the intended building work.

Due to Stainless Steel being incompatible with Zinc, CoreClad may not be suitable for use with steel framed house construction.

Wall underlays

A breather type wall underlay meeting, as a minimum, the performance requirements of E2/AS1 Table 23 is required. Where relying on a Product Certificate (CodeMark) or BRANZ Appraisal is acceptable, ensure the conditions of use and scope are appropriate.

When replacing existing claddings with CoreClad, IBuilt recommends that existing wall underlays are replaced.

Direct fixed or cavity construction

IBuilt CoreClad may be direct-fixed or fixed over a drained, ventilated cavity depending on the risk score. Refer to E2/AS1 paragraph 3.1 and 9.1.8.

Where a drained cavity is required it must be designed to meet the requirements of E2/AS1 paragraphs 9.1.8 to 9.1.9.4.

Cavity closer/vermin proofing is to be in accordance with E2/AS1 9.1.8.3 and Figure 66.

Ground clearances

Specify ground clearances. Ground clearances must be at least 175mm clear of soil and 100mm clear of paving. Refer to Detail 1.12 CoreClad Cladding Base of Wall (page 12).

Fixings

Stainless steel fixings (type 316) must be used when installing CoreClad to minimise the possibility of bi-metallic corrosion.

Configuration for horizontal joints

Horizontal joints are to be in accordance with E2/AS1 paragraph 9.8.3.2.

Flashings

Stainless steel or PVC flashings are to be in accordance with E2/AS1 paragraph 9.8.4 and 9.8.5. Check material compatibility as per E2/AS1 Table 21 and 22.

Stainless steel or PVC flashings must be used with CoreClad to minimise the possibility of bi-metallic corrosion.

Powder coated aluminium flashings may only be used if an adequate separation barrier is used between cladding and flashing.

This can be achieved by using DPC, polythene (min 200microns) or flashing tape. Or, maintain a clearance of 5mm minimum between materials.

Windows and doors

Windows and doors are to be in accordance with E2/AS1 paragraph 9.1.10 and Figure 115 for direct fixed construction or Figure 116 for cavity construction. Ensure 5mm clearance of joinery to cladding is maintained.

Coating

Specify the type of finish to be applied. IBuilt CoreClad is intended to be used with a paint finish. Dark coloured paint should only be used with caution and IBuilt recommends a minimum light reflective value (LRV) of 40%. For more information refer to page 7.

External structures

Where an external structure such as a deck or pergola is connected to the building, an H3.2 treated timber packer with EPDM washer must be used at all bolt locations to ensure moisture is not trapped between structure and cladding. Refer to detail 1.13 (direct fixed) and 2.13 (cavity system).

Documentation

Ensure the building consent plans and specifications clearly define all:

- Fixings – type and installation
- Flashings – type and installation
- Relevant details.

The installer will be relying on these documents, along with this guide, to install CoreClad correctly and in accordance with the building consent (where applicable).

Commonly used installation details

- Direct fixed (pg 11).
- Cavity Construction (pg 14).

Installation

Key documents for referencing

- Building consent plans and specifications
- E2/AS1
- NZS 3604:2011
- This guide.

Primary structure

The substrate must be straight, true and within the framing tolerances of NZS 3604, Section 2 and Table 2.1 or where existing, suitable for the installation of CoreClad.

Vertical studs must be at maximum 600 mm centres, with horizontal nogs/dwangs fitted flush between the studs at maximum 800 mm centres.

Refer to 'cavity construction' section for stud and nog/dwang spacings.

Wall underlays

The specified wall underlay must be installed. Where an alternative is to be substituted, ensure that it is a like for like substitution.

Where a rigid air barrier is installed, as a temporary cladding, it must be installed in accordance with the rigid air barrier's technical specifications. Ensure that CoreClad is installed over the rigid air barrier within the recommended exposure period.

Cavity construction

Where IBuilt CoreClad is to be installed over a drained cavity, the cavity must meet the requirements of E2/AS1 paragraphs 9.1.8 to 9.1.9.4.

The wall underlay must be restrained from bulging into the drained cavity by applying polypropylene tape at 300 mm centres or additional battens.

Cavity closer/vermin proofing must be in accordance with E2/AS1 9.1.8.3 and Figure 66. Cavity closer/vermin-proofing must be installed at the base of all walls, open horizontal (or raking) junctions and over openings (windows, meters etc). Length and width of cavity closer/vermin-proofing applied must suit the cavity. Openings in cavity closer/vermin-proofing must be clear and unobstructed.

CoreClad can be fixed over structurally fixed cavity battens, refer to BRANZ Bulletin BU582.

Moisture content

CoreClad panels must have a moisture content of less than 18% before installation.

Layout

Establish stud centres as per the consent. Establish layout to ensure panel joints align with the centre line of framing members, and to optimise panel usage to avoid unnecessary wastage and joints.

Flashings

Install necessary flashings. Refer to building consent details and E2/AS1. All sills, heads, jambs, wall openings, penetrations, intersections must be flashed prior to installation of IBuilt CoreClad panels.

Stainless steel or PVC flashings must be used with CoreClad to minimise the possibility of bi-metallic corrosion.

Powder coated aluminium flashings may only be used if an adequate separation barrier is used between cladding and flashing.

This can be achieved by using DPC, polythene (min 200 microns), flashing tape or, maintain a clearance of 5mm minimum between materials.

Install CoreClad™

IBuilt CoreClad panels are to be fixed through the wall underlay into the wall framing as required in E2/AS1 Table 24. Ensure all panel horizontal joints are as detailed in the building consent and E2/AS1. Use laser or mechanical devices to set-out all nailing accurately in straight lines.

- **CoreClad is veneer treated, which means on-site re-treatment of cut-ends is not required.**
- Do not fix CoreClad through the drainage rebate on the panel edge.
- Install all sheets vertically
- Do not nail through the top of the shiplap
- Use temporary 9mm spacer while fixing grooved sheets
- Non-Grooved sheets require a 2mm gap between sheets to allow for expansion.

Fixings

Stainless steel fixings (type 316) must be used when installing CoreClad to minimise the possibility of bi-metallic corrosion. See CoreClad sheet fixing set out on page 9 for more details.

Windows and doors

Install windows and doors as set out in the building consent details. Refer to E2/AS1 paragraph 9.1.10 and Figure 115 for direct fixed construction or Figure 116 for cavity construction. A set of common installation used details have been included in this guide for reference. Ensure 5mm clearance of joinery to cladding is maintained.

Quality check

On completion, visually inspect all sides of the building ensuring the cladding system is completely weather-tight. The building owner should be advised of all maintenance requirements.

Coating

The New Zealand Building Code Clause B2 requires claddings to achieve a minimum structural durability level of 15 years. IBUILT CoreClad will meet this requirement when coated with paints or stains to the coating manufacturer's specifications.

It is the responsibility of building owner, specifier and applicator for the selection, application and maintenance of coatings. For advice on specific coating products, surface preparation, and general coating practice always refer to the coating manufacturer.

Ask IBuilt for samples of CoreClad to be used as coating test pieces.

Coating Selection

The selection of the right coating is important and needs to take a number of factors such as the level of protection, durability and the frequency of maintenance into consideration. It is important to note that specifically with CoreClad 2745mm and 3050mm length sheets, the scarf joint has a visible dark line going across the panel and the two sections may have colour differences.

Colour Selection

An important part of selecting a colour is understanding the colour's Light Reflectance Value (LRV). LRV refers to how a light or dark paint colour will look on a scale of 0 (black) to 100 (white). The higher the LRV number, the lighter the colour. The colour LRV recommended for CoreClad is greater than 40.

Any colour with a LRV less than 40 runs the risk of reducing the durability and lifespan of the sheet.

- Using colours with an LRV of less than 40 i.e., dark colours, homeowners need to increase the level of coating maintenance over the lifetime of the cladding when compared to lighter colours.
- In addition, using dark colours increases the risk of issues such as face checking (see Face Checking page 8).

Regardless of colour choice, CoreClad coated with paints or stains will meet the performance requirements of NZBC Clause B2.3.1. which requires claddings to achieve a minimum structural durability level of 15 years.

Coating Options

1. Paint (Recommended)

To provide the highest level of protection and durability for CoreClad the recommended coating system by paint manufacturers is three coats (1 undercoat, 2 top coats) of a premium, 100% acrylic paint system in a light colour (LRV greater than 40) combined with a regular maintenance programme (see CoreClad Warranty Care and Maintenance Guide). This system is likely to require the least amount of coating maintenance (repainting) over the life of the cladding. It can also help hide the scarf joint on 2745mm and 3050mm length sheets. Paint offers more protection than stain against mechanical and UV degradation.

Full pigment paints perform better than stains. The more pigment in the paint the more resistance to UV degradation and resultant breakdown of the face veneer. UV degradation

is the process whereby ultra violet light (UV) breaks down components of the wood.

2. Penetrating stains

Penetrating type stains offer less protection than paint from exterior weathering that leads to mechanical and UV degradation. Stains require more regular maintenance during the panel's life.

If staining, a batten can be used to hide the scarf joint on 2745mm and 3050mm length sheets.

Preparation

Primed sheets can be painted immediately after installation with a suitable coating system.

Prior to the application of any coating ensure the sheet surface is dry and free from dirt, dust, mould and any other contaminants. If required, wash with a mild detergent and allow to dry.

Before washing down, use a soft bristle brush to clean the grooves on CoreClad Groove150.

Spot prime any nail heads, gaps and cut edges with a quick dry acrylic primer.

Application

Check with your coating's manufacturer for the recommended preparation and application method to suit the conditions for your project. Ensure an adequate coating is applied as per the directions of the paint or stain manufacturer's data sheets.

CoreClad must be coated within 3 months of installation. Paint manufacturers recommend not leaving bare timber for more than 4 weeks before painting or staining. Ensure the panel is dry before applying the priming coat and within the temperature and moisture content parameters recommended by the paint manufacturer.

Priming of the sheet face, edges, and the back of the bottom of the sheet to a height of 150mm is recommended. Topcoat with a minimum of 2 coats of premium 100% acrylic exterior house paint, as per the paint manufacturer's instructions, in accordance with the appropriate clauses in AS/NZS 2311 Guide to Painting of Buildings. Sheets installed close to the ground or above flashings need to be primed on the back of the sheet to 150mm from the bottom edge.

For CoreClad Groove150 (Natural and Primed), paint the grooves first using a hand brush and then paint the surface. After the recommended re-coat time, repeat for the second, and third coat, if required. A third topcoat is recommended on north facing walls, where the building is in harsh climates such as coastal or alpine regions, or where a dark colour with an LRV less than 40 has been used.

CoreClad™ Primed

Each sheet is coated with a premium acrylic primer in factory conditions, the sheets are primed on the face, edges and the bottom 150mm on the back of the sheet. The primed sheets require a minimum of two topcoats, with each topcoat being a minimum of 25 microns. A third coat is recommended for north facing walls, harsh climates, or where dark colours as being used.

CoreClad Primed may be painted with most common exterior domestic paint systems including water borne acrylic paints and water borne enamel systems. Application of solvent based/catalysed topcoats is not recommended as the flexibility of the plywood substrate may induce cracking of the topcoat.

Do not use active organic solvents such as thinners or methyl ethyl ketone (MEK) on CoreClad Primed.



Unpainted with Scarf Joint / Painted with Scarf Joint.

Face Checking

Face Checking

Face checking are fine splits that run in the direction of the grain in the face veneer of plywood and can sometimes be seen on panels that have been exposed to the weather. The splits are the result of natural cyclic expansion and contraction of the timber due to changing moisture content, which can be associated with changing temperature i.e. when exposed to heat and cold. The results of expansion and contraction can be amplified further by painting in darker colours. The initial face checking is superficial and does not alter the structural integrity of the plywood, however if allowed to continue can cause a breakdown of the face veneer.

The addition of a 3rd top coat after 4-6 months can help offer additional protection to any checks or splits that have appeared.

Health & Safety, Storage & Handling

Health and safety

Take all necessary steps to ensure your safety and the safety of others:

- Ensure adequate ventilation or mechanical dust extraction when cutting or drilling.
- Ensure the timber is well supported when cutting and nailing.
- Wear appropriate safety equipment, clothing and footwear.
- Use all tools in accordance with relevant instruction manuals.
- Plan and monitor a safe approach for working at height; select and use the right equipment.
- Clear the work area of any obstructions before work starts.

For further information refer to:

- WorkSafe Small Construction Sites, The Absolutely Essential Health and Safety Toolkit, July 2018.
- WorkSafe Health and Safety at Work, Quick Reference Guide, December 2016.

These documents are available at www.worksafe.govt.nz.

Storage and handling



Correct handling and storage of I Built CoreClad is critical for best performance, ease of use and warranty adherence.

I Built CoreClad should be delivered dry, unmarked and undamaged from freight and handling. All panels should be inspected upon the delivery. I Built CoreClad should be lifted off the truck by hoist or hand.

The storage area should be ventilated and protected from sun, rain and wind. These conditions could bring about rapid changes to temperature and humidity. Correct storage avoids the potential for staining, fading or surface checking prior to installation.

Stack panels horizontally, dry and clear off the ground by 100 mm and supported on dry, clean timber bearers at maximum of 900 mm centres and at both ends of the panels to avoid distortion.

Keep panels dry at all times; either by storing within an enclosed building or use an additional weatherproof cover as a secondary to packaging wrap if stored outside, but also ensure that there is sufficient air flow to avoid condensation. Avoid storing over standing water or vegetation.

Delivery should be timed to allow minimum time sitting on site, especially when panels are in unfinished, damp buildings or in an uncovered building allowing the chance of moisture uptake. Extra care must be taken to avoid damage to panels edges and surfaces, especially during installation.

NOTE: When coating CoreClad prior to installation, some coatings may require the sheets to be separated or slip sheeted when in storage.

Care and maintenance



To get the best performance out of CoreClad, it is required to be regularly checked, washed and maintained.

Please refer to the I Built CoreClad Care and Maintenance guide for maintenance recommendations.

When CoreClad is maintained using these recommendations CoreClad will last a minimum of 15 years in accordance with clause B2 Durability, NZBC.

Framing

Framing set out requirements

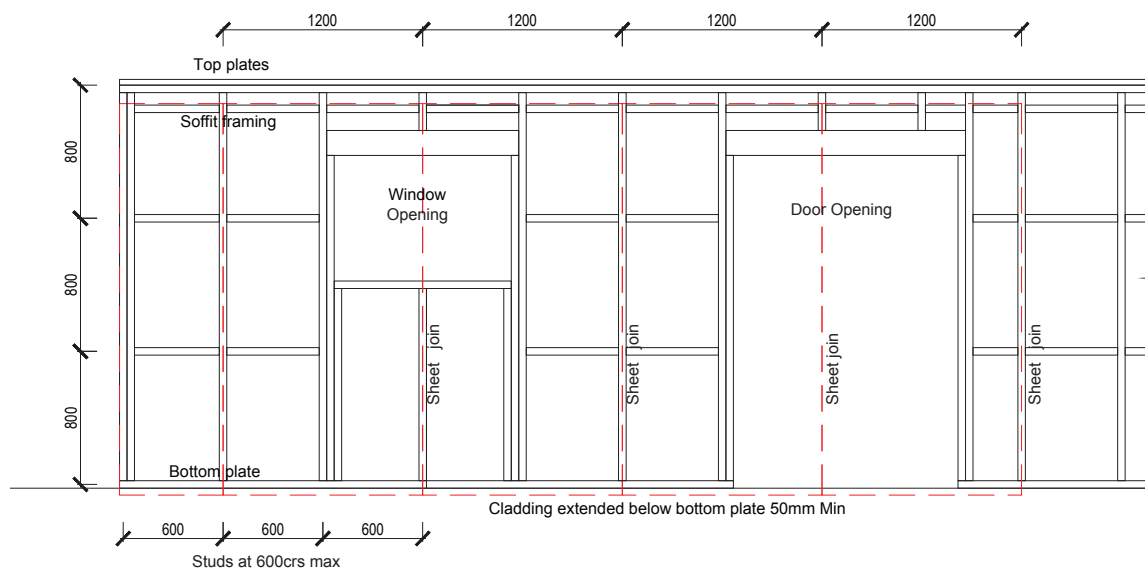

Framing set out requirements - Cavity battens

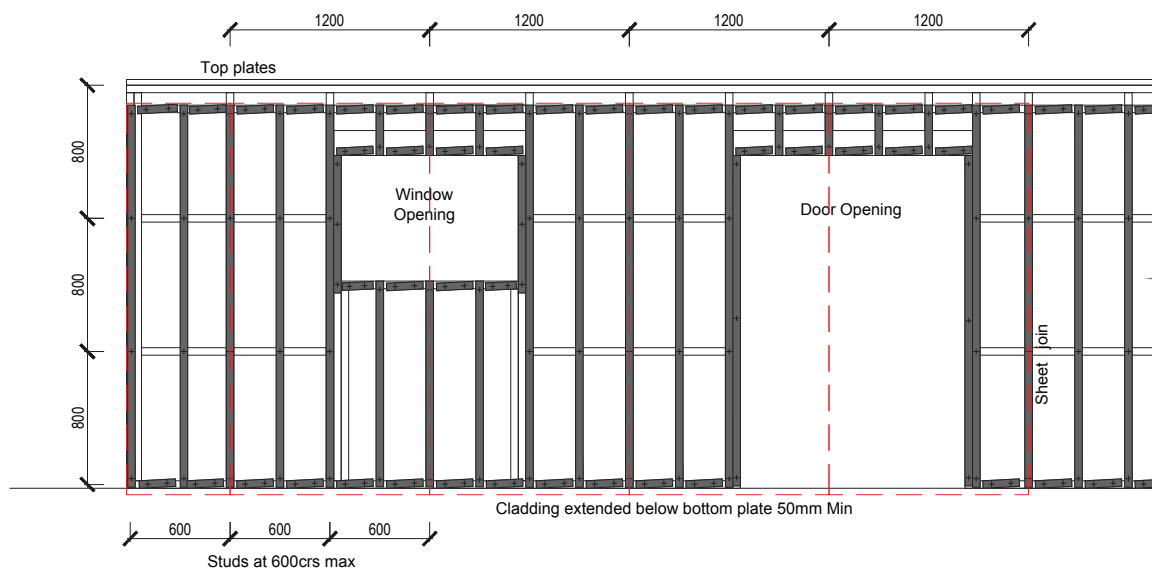

CoreClad™ sheet fixing set out

Fixing Type	Direct Fixed	Cavity Fixed
Nails (SS) (Type 316)	50x2.8mm	60x2.8mm
Screws (SS) (Type 316)	40x8g	65x8g

Fixing Notes:

- Galvanised fixings are not permitted. All fixings must be stainless steel.
- All sheet edges must be supported by wall framing.
- CoreClad sheets must be installed vertically.
- Do not fix through the grooves.
- Fixings are to be driven flush with the surface. Do not over drive fixings.
- Only fix to cavity battens that are located over wall framing to avoid damage to building wrap.
- Fixings to be no closer than 7mm to sheet edges.
- Do not fix through the top lap or weather groove of the shiplap.

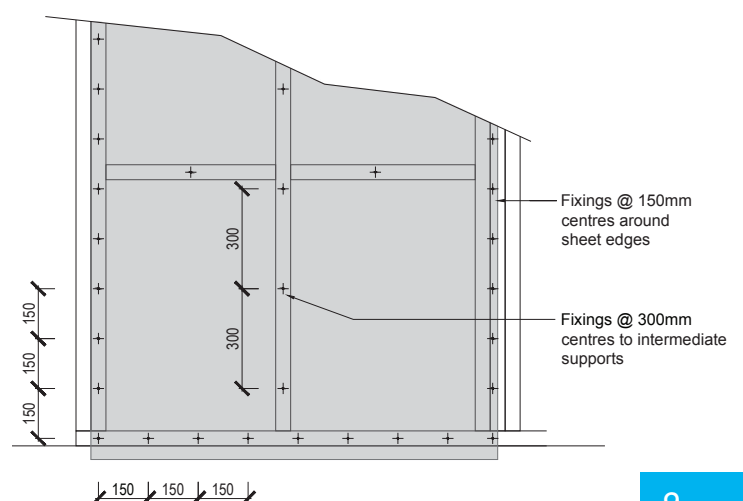

Sheet Profiles

Shi lap

Do not fix through the top lap or weather groove of the shi lap.

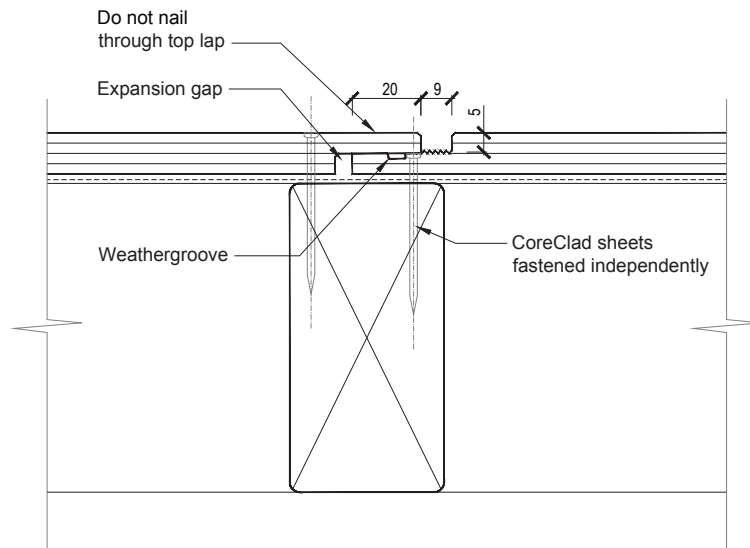

Grooved sheet dimensions

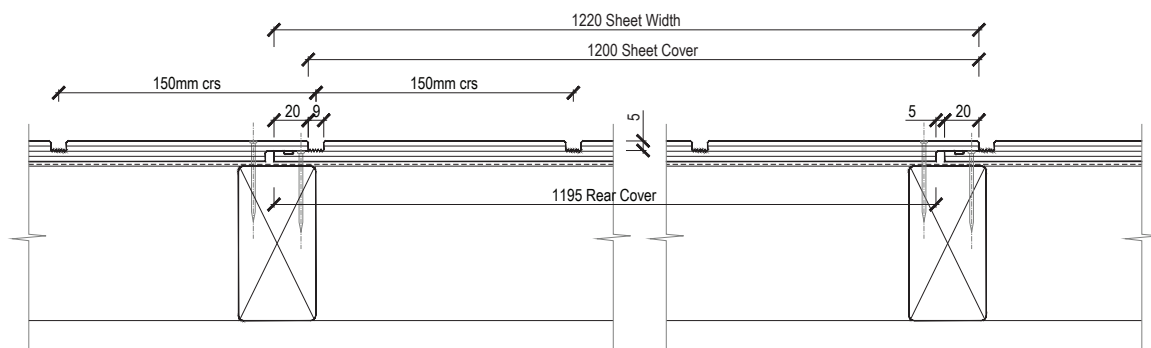

Ungrooved sheet dimensions with optional batten

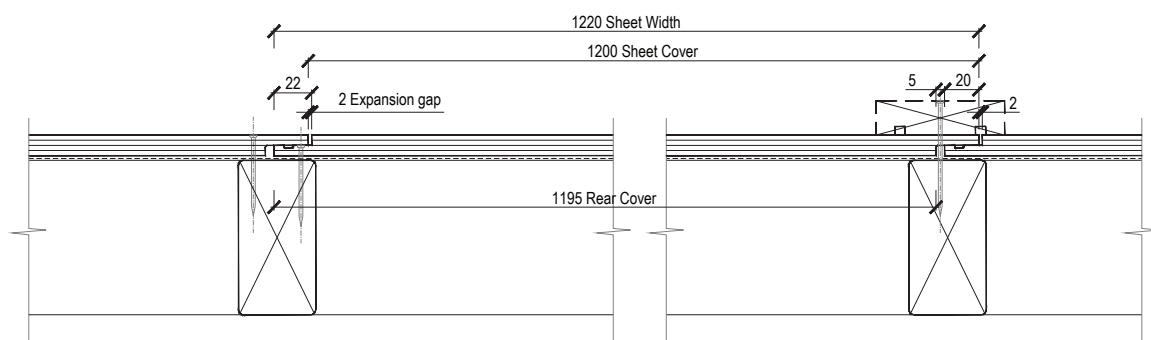

Installation Details Direct Fixed

1.1 CoreClad™ Window Head Detail

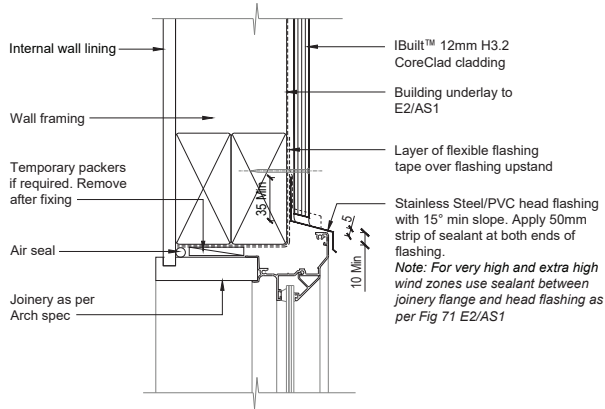

1.4 CoreClad™ Internal Corner

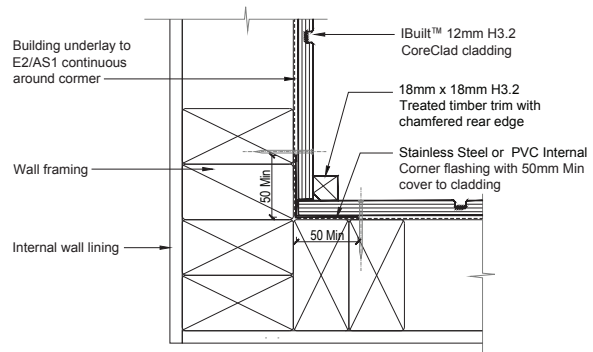

1.2 CoreClad™ Window Sill Detail

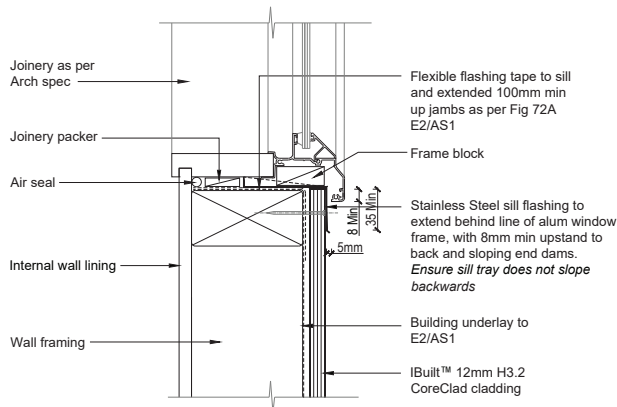

1.5 CoreClad™ Internal Corner - 'W' Flashing

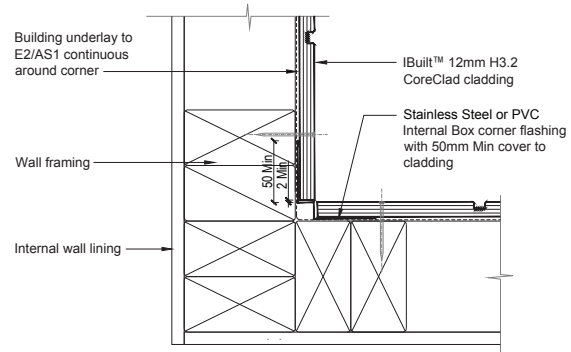

1.3 CoreClad™ Window Jamb

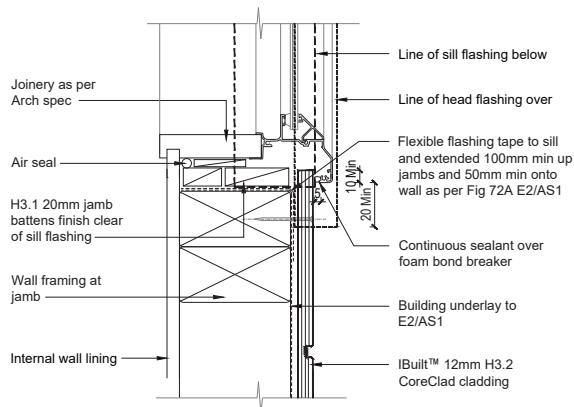

1.6 CoreClad™ External Corner - Battened

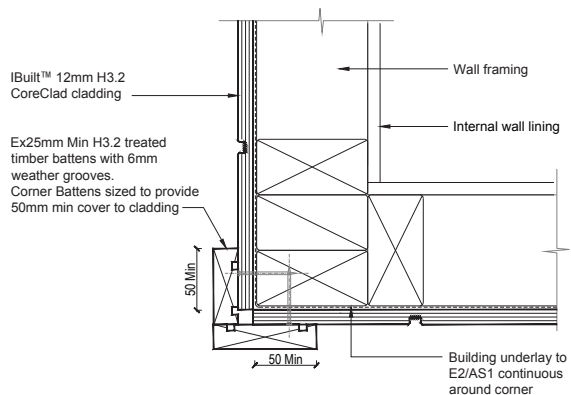

1.7 CoreClad™ External Corner - Box Flashing

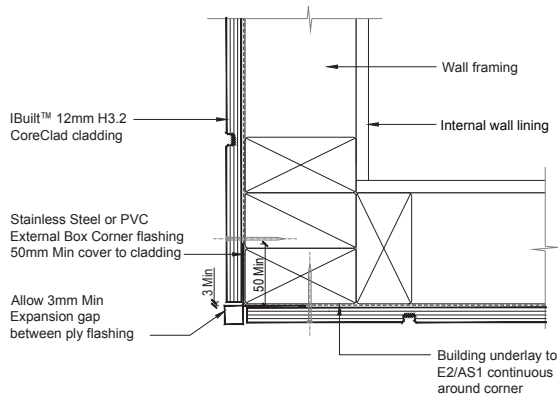

1.10 CoreClad™ Vertical Sheet joint - Battened

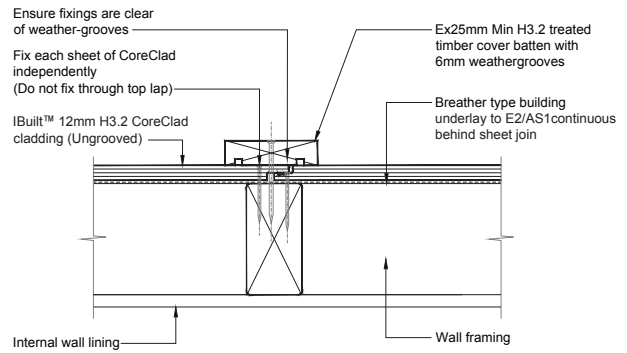

1.8 CoreClad™ Horizontal Junction

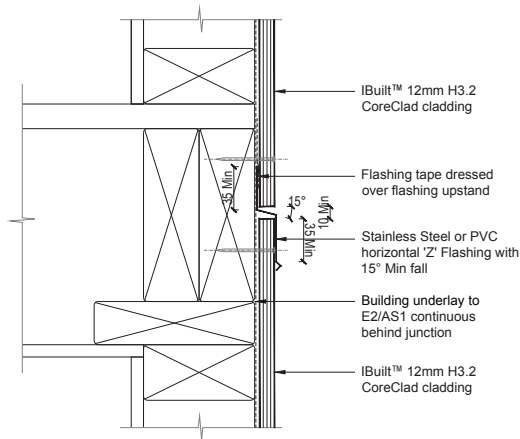

1.11 CoreClad™ Soffit Junction

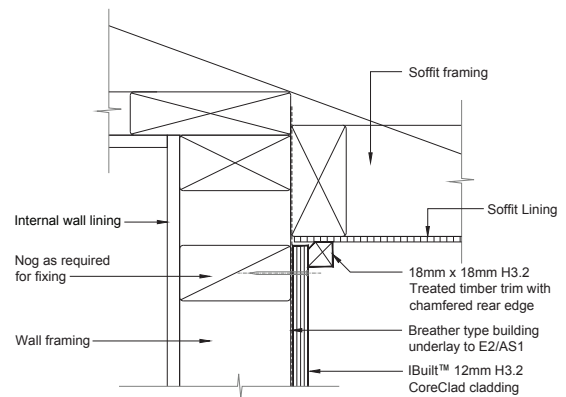

1.9 CoreClad™ Vertical Sheet Joint

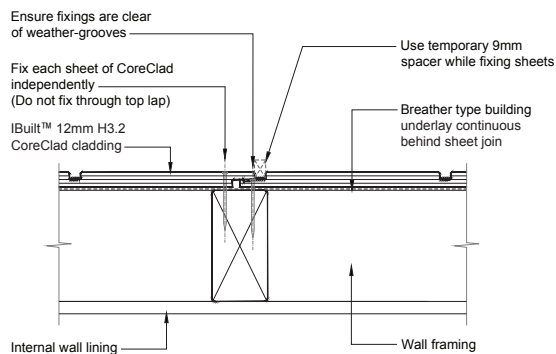

1.12 CoreClad™ Cladding Base of Wall

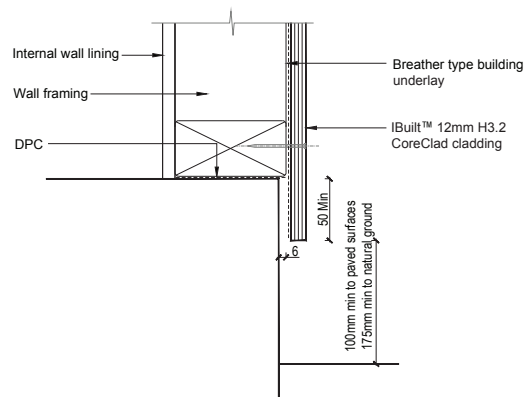

1.13 CoreClad™ Deck Connection Detail

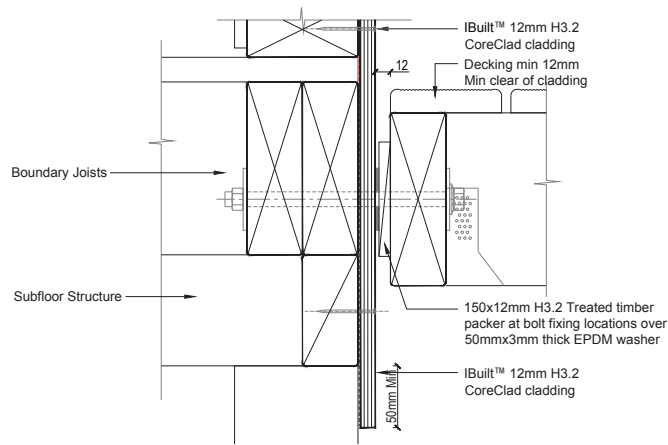

1.14 CoreClad™ Pipe Penetration Detail

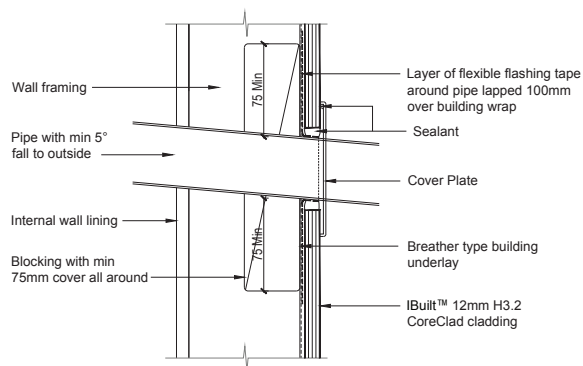

Installation Details Cavity Construction

2.1 CoreClad™ Window Head Detail

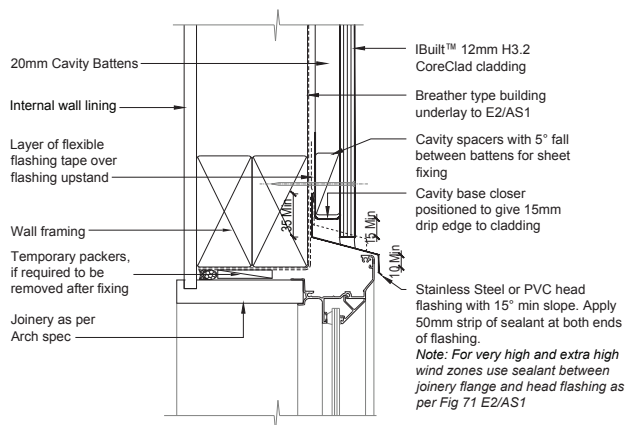

2.4 CoreClad™ Internal Corner

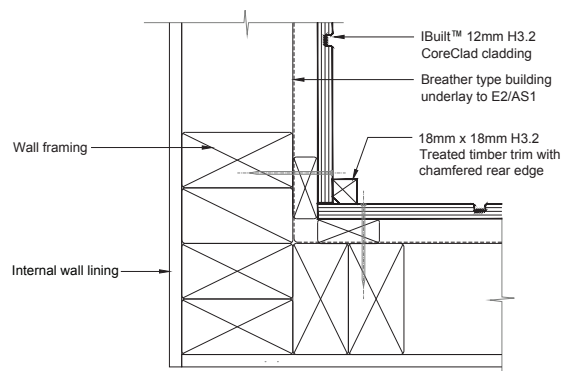

2.2 CoreClad™ Window Sill Detail

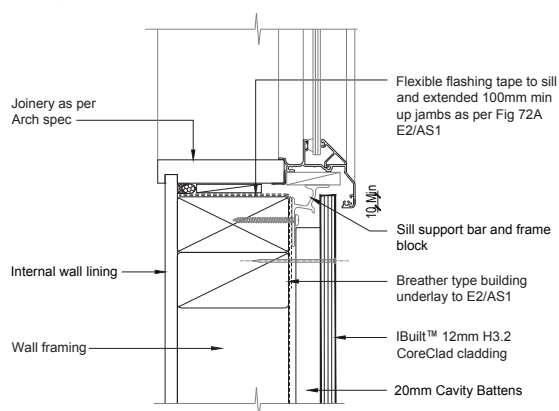

2.5 CoreClad™ Internal Corner - 'W' Flashing

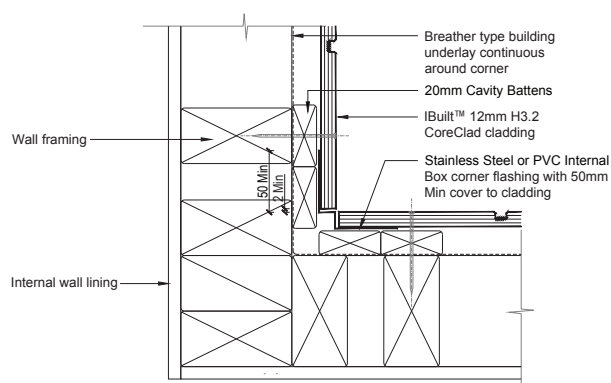

2.3 CoreClad™ Window Jamb Detail

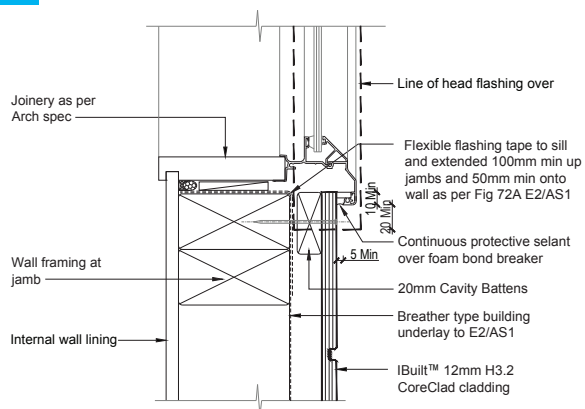

2.6 CoreClad™ External Corner - Battens

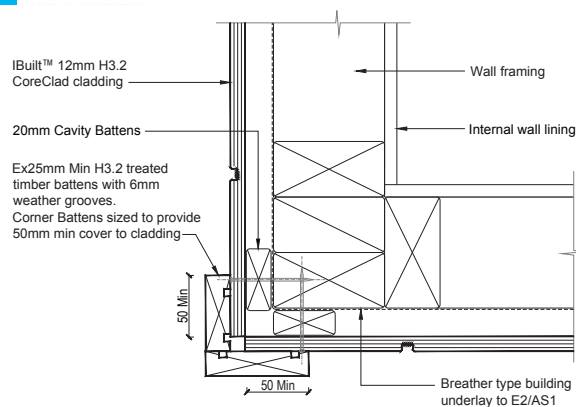

2.7 CoreClad™ External Corner - Box Flashing

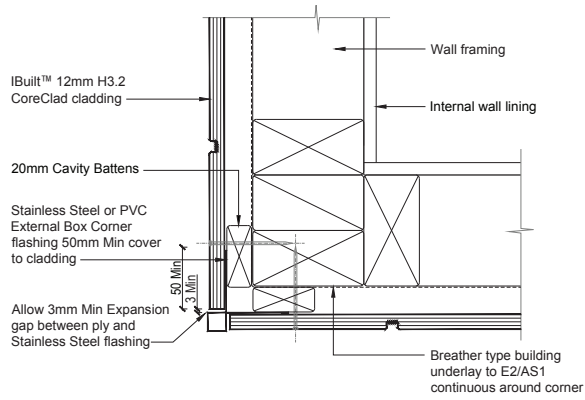

2.10 CoreClad™ Vertical Sheet Joint - Batten

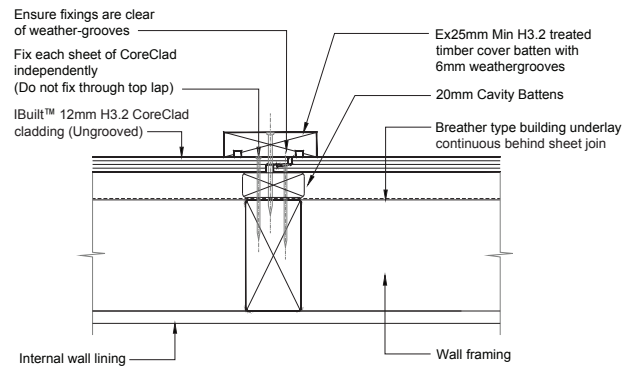

2.8 CoreClad™ Horizontal Junction

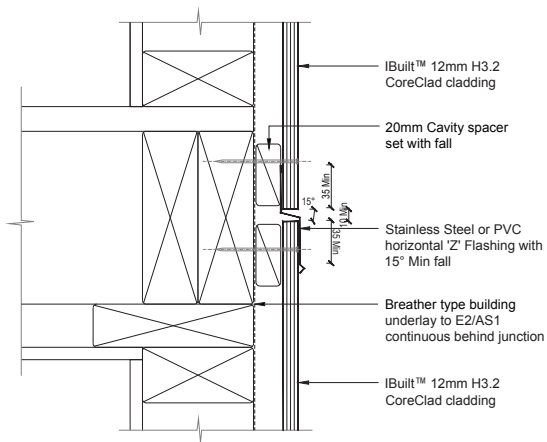

2.11 CoreClad™ Soffit Junction

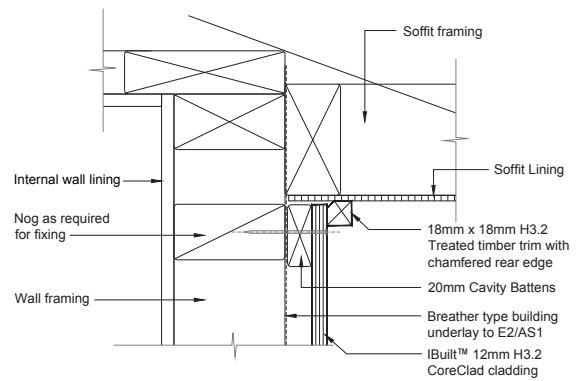

2.9 CoreClad™ Vertical Sheet Joint

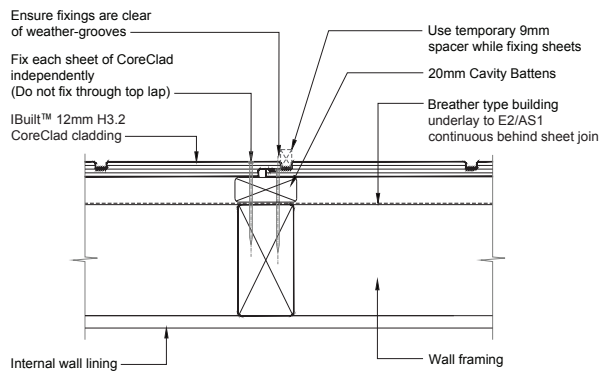

2.12 CoreClad™ Cladding Base of Wall

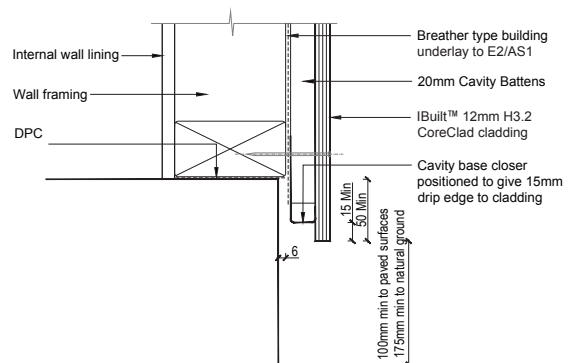

2.13 CoreClad™ Deck Connection Detail

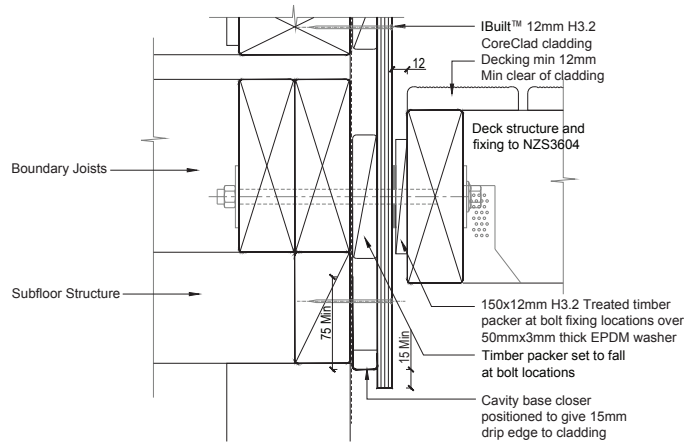

2.14 CoreClad™ Pipe Penetration Detail

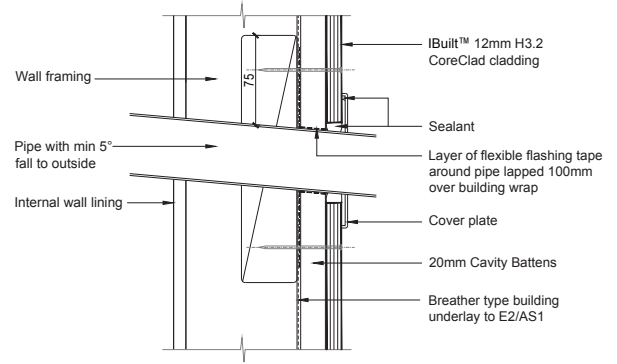

NZWOOD

NEW ZEALAND WOOD PRODUCTS LIMITED

📍 149 Kerrs Rd, Wiri, Auckland

📦 PO Box 76412, Manukau, Auckland 2241, New Zealand

👤 Tech Info Line: 0800-022-352

📞 Phone: +64-9-268 6540

✉️ sales@ibuilt.co.nz
techinfo@ibuilt.co.nz

👉 www.ibuilt.co.nz