



EDGESMITH

358DV MESH

Security Anti-scale Welded Mesh Panel

PRODUCT CODE:

358DV-22x24

MATERIAL:

HDG Rigid Wire 4mm Dia

FINISH:

Hot Dip Galvanised

SHEET WEIGHT:

10.5 kg/m²

RECOMMENDED POST:

Steel 75 SHS x 3.0mm

FIXINGS REQUIRED:

Ordered Separately

- Mesh Clips
- Security Screws and Nuts
- Rails



For more information scan the QR code

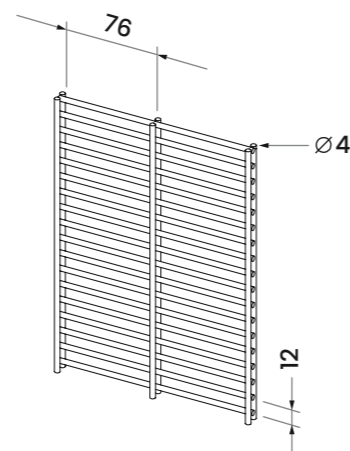
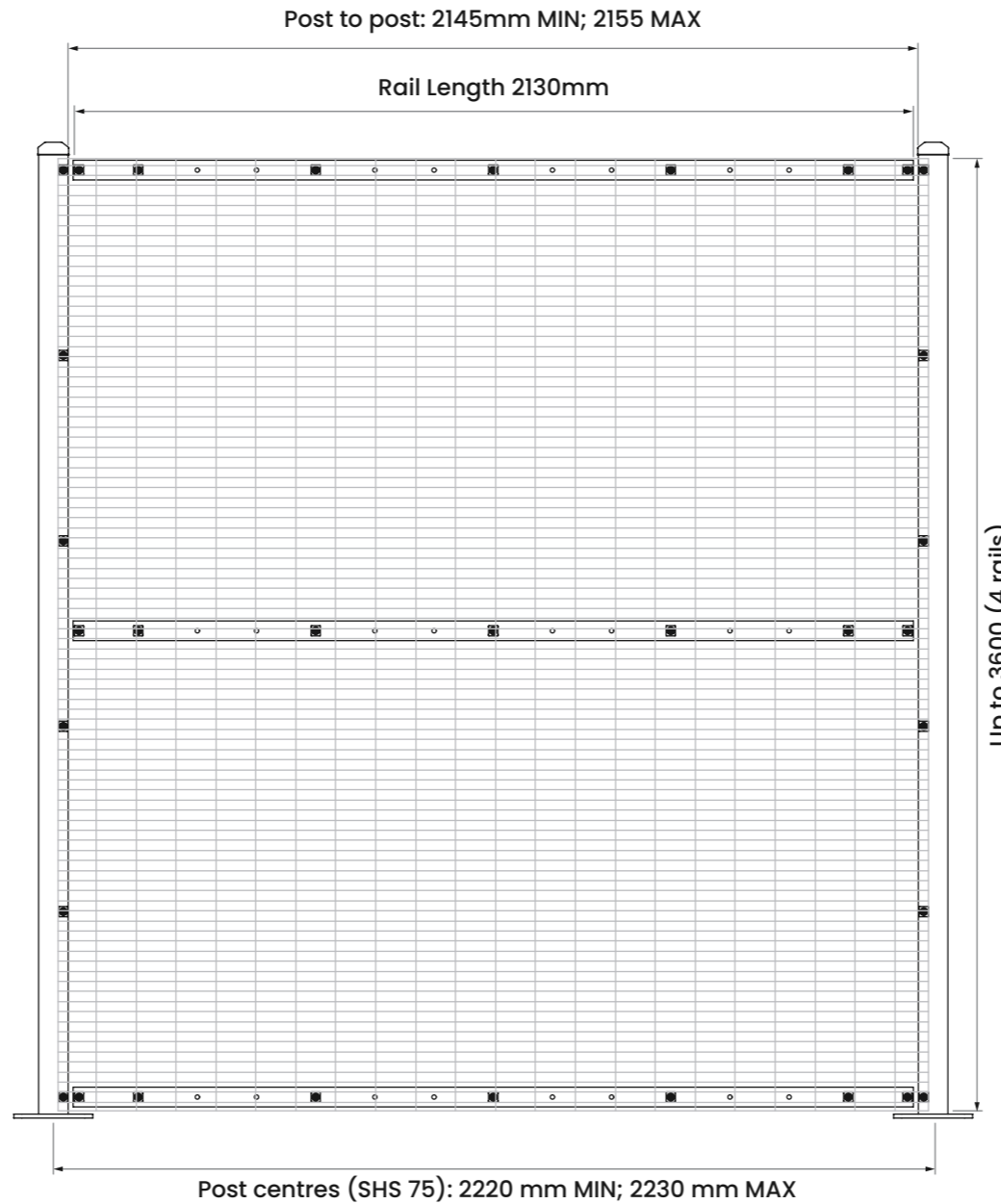

Rail End Detail

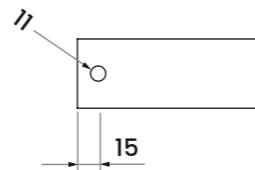

Rail Detail

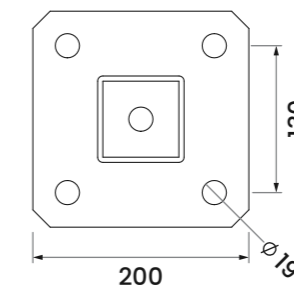
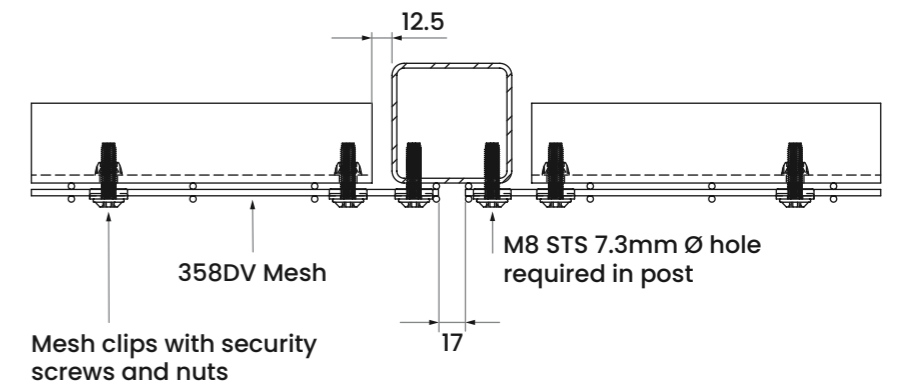
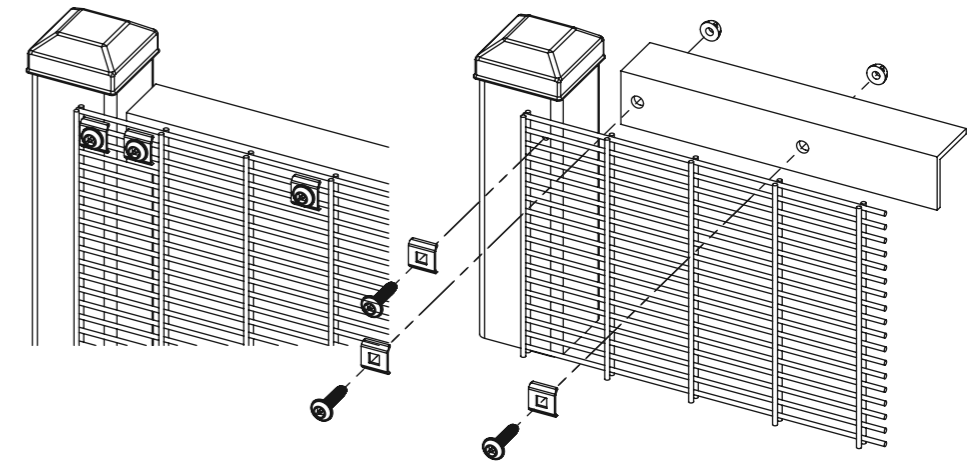

Flange Post

Post Size: 75mm
Flange Thickness: 10mm

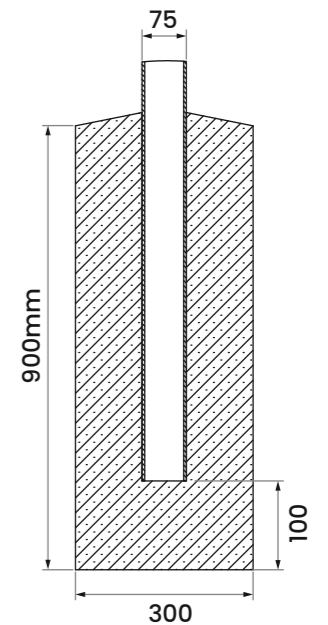

Inground Post

