



PRODUCT TECHNICAL DATASHEET

# BAMBINO



SWING



SLIDING



CANTILEVER



## BAMBINO BM30

Electromechanical HIGH SPEED BRUSHLESS motor, low voltage, super intensive use, onboard encoder, ideal for sliding gates up to 400kg with built in digital controller and magnetic limit switch.



Brushless



Intensive Use



High Speed



Digital Encoder

### Dimensions

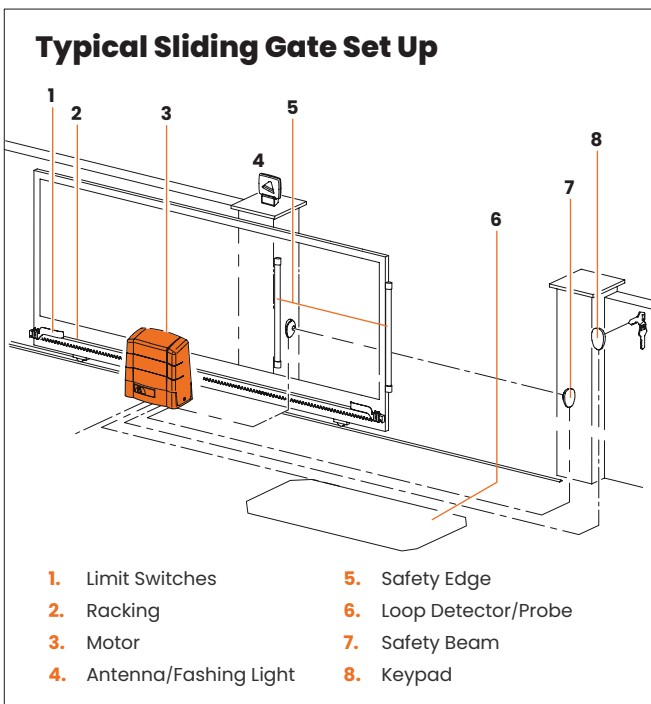
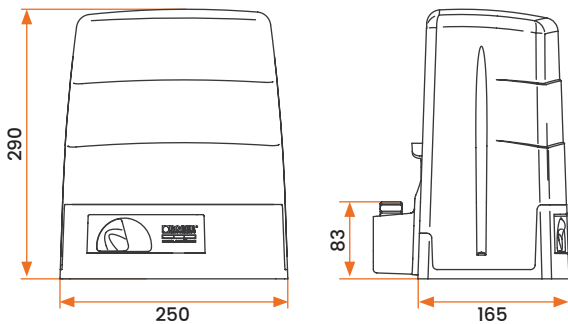

<b>Max Gate Weight</b>	400 kg
<b>Maximum Gate Length</b>	12m
<b>Power Line Supply</b>	230V AC - 50Hz
<b>Motor Power Supply</b>	24V
<b>Power Rating</b>	125W
<b>Duty Cycle</b>	100% Intensive Use
<b>Thrust</b>	50 - 350N
<b>Operating Temperature</b>	-20+55°C
<b>Protection Level</b>	IP43
<b>Reductor Type</b>	Irreversible
<b>Manoeuvre Speed</b>	26 m/min (0.44 m/s)
<b>Limit Switch</b>	Magnetic
<b>Onboard Control Unit</b>	B70/IDC
<b>Encoder</b>	Digital encoder + magnetic digital SENSORED, 4096 PPR
<b>Batteries Recovery</b>	Optional 2 external battery 12V 7AH
<b>Type Exit Gear</b>	Z15/mod 4
<b>Maximum Power Absorbtion</b>	320W
<b>Maximum Start Up Force</b>	350N
<b>Maximum Friction At Start</b>	40N

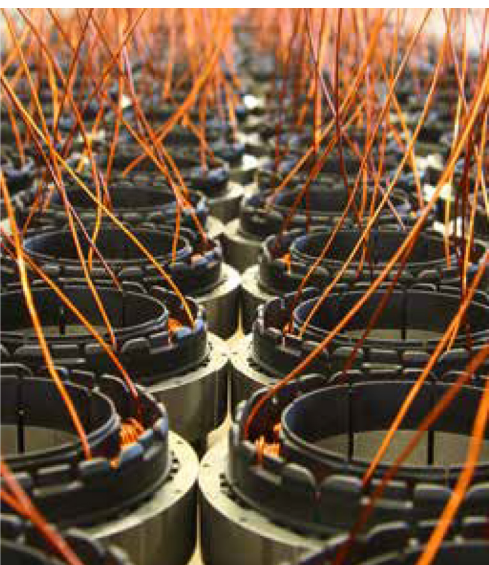
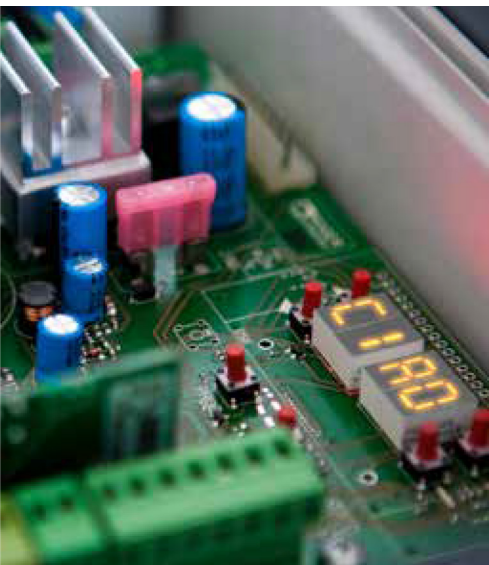
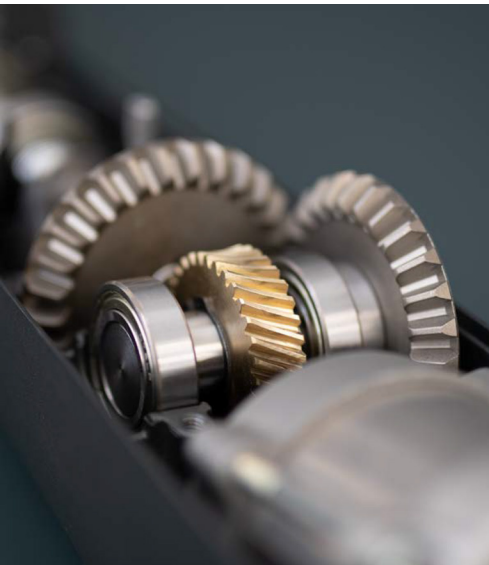

- ◆ **Brushless Digital Motor**  
Features a compact design with neodymium iron-baron magnets, available in 24V & 36V AC versions, operating at ambient temperature with low consumption.
- ◆ **Speed & Acceleration With Maximum Safety**  
Controls motor torque precisely for smooth acceleration and deceleration, ensuring safety.
- ◆ **Super Intensive Use**  
Operates at low voltage with a 100% duty cycle, maintaining low energy consumption.
- ◆ **External Transformer For Heavy Gates**  
Low voltage options reduce installation costs where high voltage is unavailable.
- ◆ **Extremely Low Energy Consumption**  
Consumes about 1/3 the power of other brands for the same gate weight and speed.
- ◆ **Amazingly Quiet**  
Precision gearing and smooth torque control result in very quiet operation, ideal for residential applications.
- ◆ **Powerful Digital Encoder**  
SENSED technology provides 4096 pulses per revolution for precise control and safety in obstacle detection.
- ◆ **Limit Switch**  
Available with magnetic limit switches.
- ◆ **Standby Batteries**  
Emergency battery backup system available, with optional 'fail open' setting during power outages.
- ◆ **Multifunctional Digital Display**  
4-quadrant display with 6 function keys for parameter adjustment, error checking, and self-learning.
- ◆ **High Precision Engineering**  
Features premium materials and double shielded ball bearings for precise alignment and durability.
- ◆ **Reinforced Aluminum Body**  
Aluminum housing reinforced with titanium and epoxy-painted for weather protection.
- ◆ **Sustainability**  
Roger Technology is a green customer-centric company dedicated to creating sustainable products through environmentally responsible production processes, innovative technologies, and a culture that prioritizes the health, safety, and development of its workers and customers.