

EDGESMITH



FOR RESIDENTIAL AND COMMERCIAL BALUSTRADES

PS1

MERCURY

Producer Statement

Commercial and Residential Balustrades

The design is in compliance with the New Zealand Building Code (NZBC), NZS 3604:2011 section B1 and F4.
Barrier loadings meet AS/NZS 1170.1:2002

Rev No. 03 | Issue Date: December 2024



MERCURY

Balustrade System

The Mercury Balustrade Panel is made from proprietary aluminium extrusions and incorporates Edgesmith's patented system that allows the assembled panel to rake up to 30 degrees without losing rigidity. The Mercury Commercial balustrade system differs from the fence system of the same name in that it has a 50x40mm top rail. Not only does the larger section feel better under hand, it has internal stiffening webs that add a huge amount of rigidity to the panel with little extra weight. It is a panel without compromise.

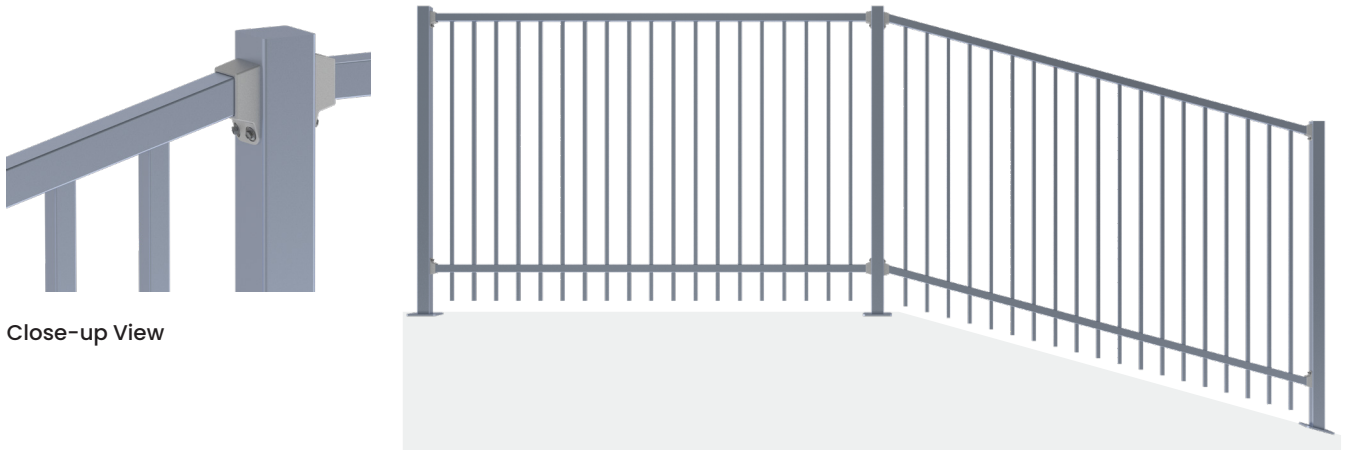

Close-up View

Applications

The New Zealand Building Code (AS/NZS 1170.1:2002) designates different occupancy types and specifies the load ratings that the system must be capable of withstanding. The system comprises of the panel, posts, fixings and the structure that the balustrade is being attached to. These are summarised in the table below. Refer to the drawings on pages 5-9 for more details.

Setting	Application	Occupancy Type	Design Load	Post Centers	Posts	Fixing Options	Details
Single Dwelling Residential	Timber Retaining Wall	A	0.35kN/m	2.4m	Alu 65SHS x 2.5 mm 6063-T5 Steel 65SHS x 2.5mm	Bolt or Coach Screw	Pg. 13
	Compliant Panel: Mercury Residential (40x40 top and bottom rails)	In-ground	A	0.35kN/m	2.4m	Alu 65SHS x 2.5 mm 6063-T5 Steel 65SHS x 2.5mm	N/A
	Timber Deck	C3	0.75kN/m	1.2m	Alu 65SHS x 2.5 mm 6063-T5 Steel 65SHS x 2.5mm	Bolt or Coach Screw	Pg. 12
Commercial, Parks, Schools and Single or Multi Dwelling Residential	Timber Retaining Wall	A, B, E, C3	0.75kN/m	2.4m	Steel 65SHS x 2.5mm	Bolt or Coach Screw	Pg. 10
	In-ground	A, B, E, C3	0.75kN/m	2.4m	Steel 65SHS x 2.5mm	N/A	Pg. 10
Compliant Panel: Mercury Commercial (50x40 top and 40x40 bottom rails)	Concrete	A, B, E, C3	0.75kN/m	1.2m or 2.4m Refer to specific details	Steel 65SHS x 2.5mm	Screw Bolt or Chem Set Rod	Pg. 11
	Concrete Block Wall	A, B, E, C3	0.75kN/m	1.2m or 2.4m Refer to specific details	Steel 65SHS x 2.5mm	Chem Set Rod	Pg. 11

AS/NZS 1170.1:2002 Table 3.3 Occupancy Reference



Fasteners And Corrosion Zones

New Zealand’s coastal climate means that attention must be paid to the proximity to salt water when choosing what fasteners to use. The table below is a guide to where hot dip galvanised fasteners can be used. While it may seem counter intuitive that sheltered installations require stainless steel fittings even within 5km of the sea, it is because regular exposure to rainfall cleans the fasteners and prolongs their life.

Environment	Corrosion Classification	Exposed	Sheltered
Within 500m of breaking surf or 50m of calm salt water	C4	All fixings 304 Stainless Steel	All fixings 304 Stainless Steel
Within 20km of salt water on West or South Coast of South Island or within 5km of salt water elsewhere	C3	All fixings Hot dip Galvanised or 304 Stainless Steel	All fixings 304 Stainless Steel
More than 20km of salt water on West or South Coast of South Island or more than 5km of salt water elsewhere	C2	All fixings Hot dip Galvanised or 304 Stainless Steel	All fixings Hot dip Galvanised or 304 Stainless Steel

Note 1: While hot dip galvanised fixings are acceptable in inland locations it is safer to use 304 grade stainless steel.

Note 2: The table above is only a guide. Please refer to SNZ TS 3404:2018, Figures 1 to 7 for specific corrosivity maps for further guidance.

Inspection And Maintenance Schedule

This schedule of ongoing maintenance of structural elements shall be included with the O&M manuals and provided to the Owner/Body Corporate and building managers.

Timeframe	Inspection / Maintenance
1/2 yearly	Wash down all exposed metalwork including panels, posts and fixings
10 yearly	Check panels, posts and fixings for signs of corrosion. Repair protective coatings or replace as required.
Following seismic shaking > SLS1 event	Inspect and repair as per the 10 yearly requirements.

Full engineers report with design calculations available on request.

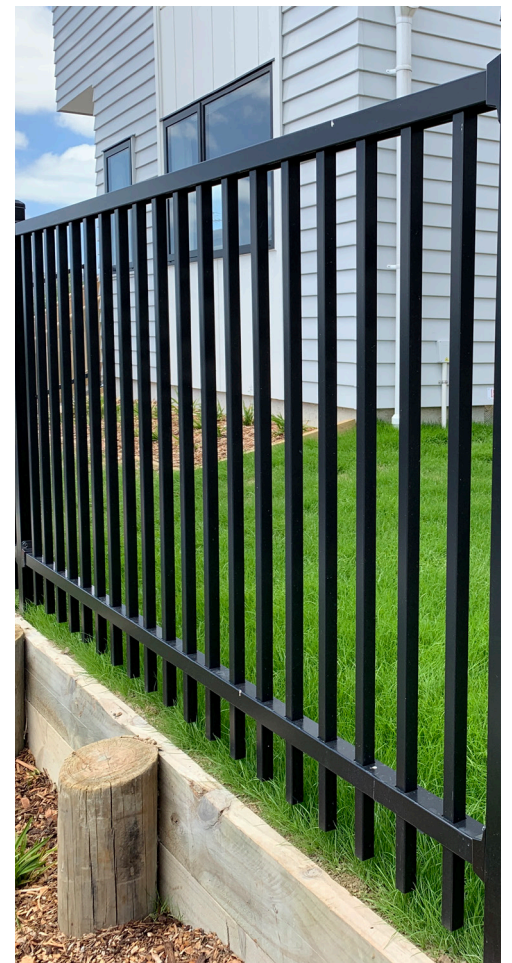



The Mercury - 1.2mH 2 Rail

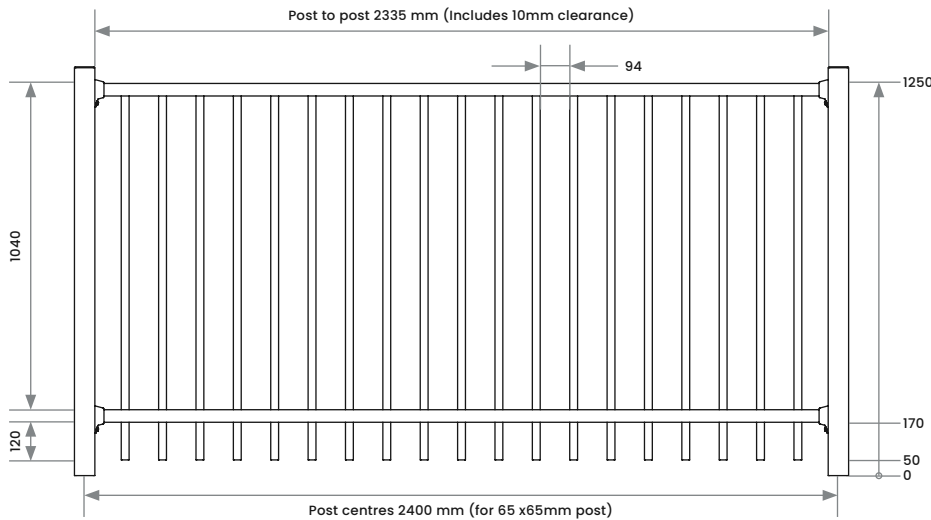

The Mercury - 1.2mH 3 Rail

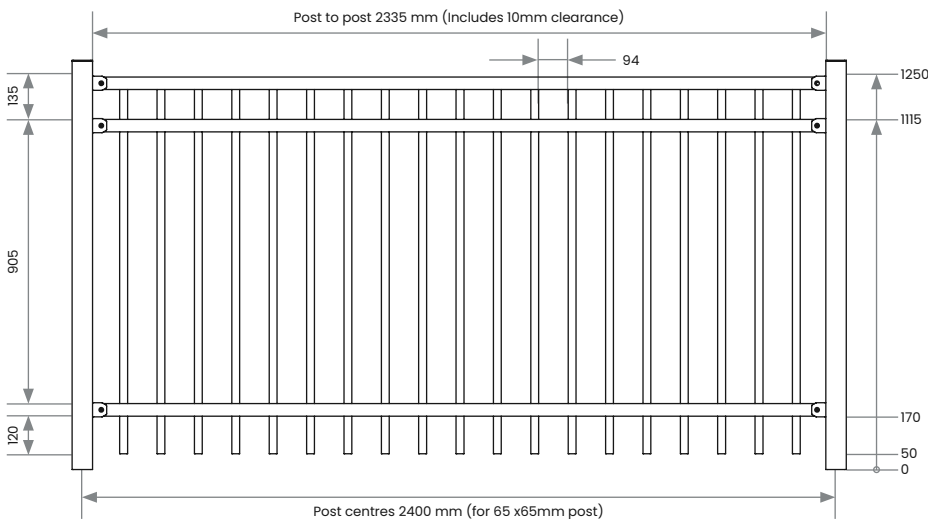

The Mercury - 1.0mH 2 Rail

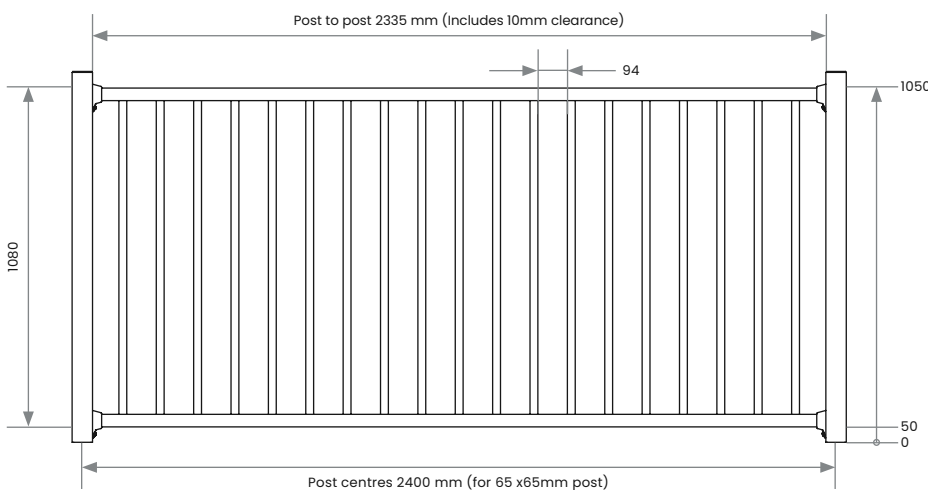

Material:

- Aluminium
- Pickets SHS 25 x 1.2mm
- Top Rail 40 x 40 Channel (50 x 40 for Balustrade)
- Bottom Rails 40 x 40 Channel

Finish:

Powder Coated

Bracket Fixings:

- Aluminium U-Brackets
- 12g Tek Screws or
- 14g Pentaforce Security
- Tek Screws (optional)

Bracket Details:

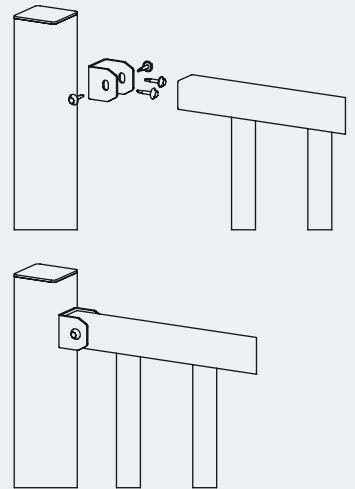



The Mercury - 1.5mH 3 Rail

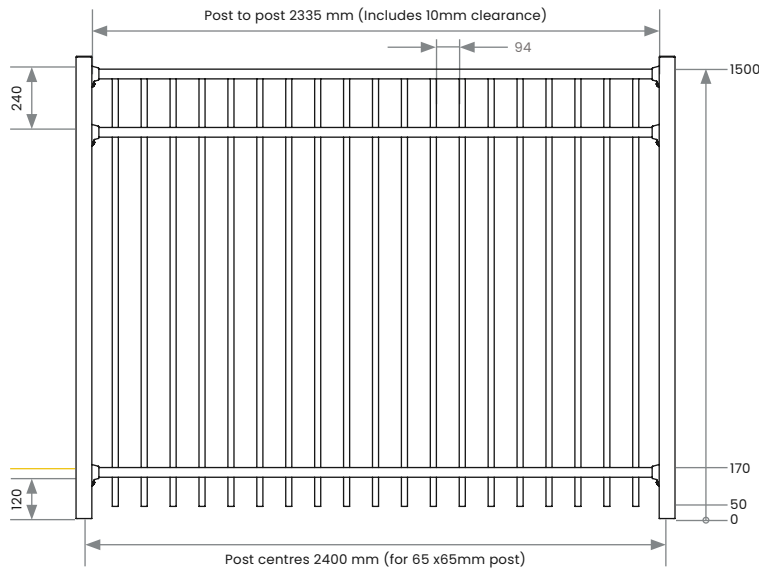

The Mercury - 1.8mH 3 Rail

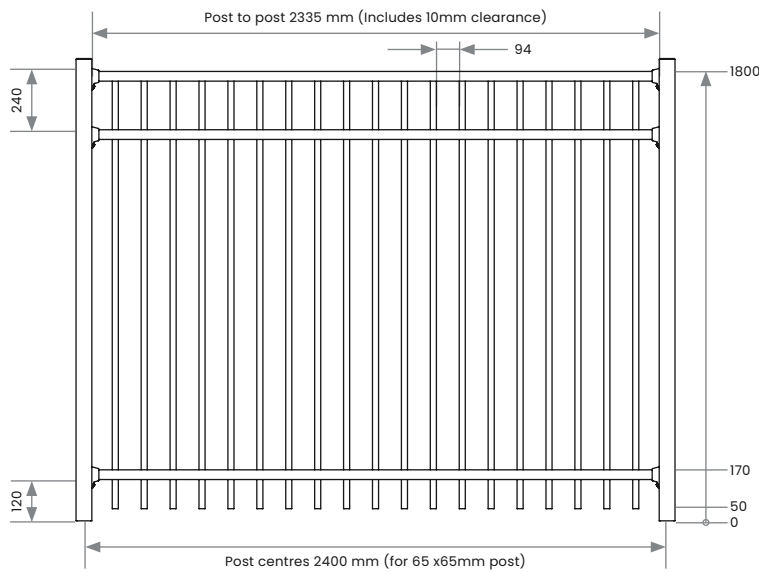

Material:

- Aluminium
- Pickets SHS 25 x 1.2mm
- Top Rail 40 x 40 Channel (50 x 40 for Balustrade)
- Bottom Rails 40 x 40 Channel

Finish:

Powder Coated

Bracket Fixings:

- Aluminium U-Brackets
- 12g Tek Screws or
- 14g Pentaforce Security
- Tek Screws (optional)

Bracket Details:

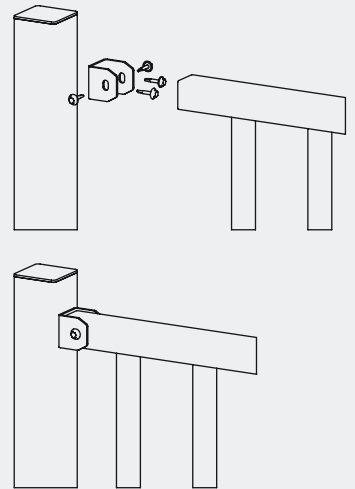



association of
consulting and
engineering

Building Code Clause(s) B1, F4

PRODUCER STATEMENT – PS1 – DESIGN

ISSUED BY: Lautrec Technology Group Limited
(Design Firm)

TO: Edgesmith
(Owner/Developer)

TO BE SUPPLIED TO: All Building Consent Authorities in NZ (Auckland Council Author Number: 1385)
(Building Consent Authority)

IN RESPECT OF: Edgesmith Mercury Balustrade Systems
(Description of Building Work)

AT: N/A (all locations in NZ)
(Address)

Town/City: **LOT** **DP** **SO**
(Address)

We have been engaged by the owner/developer referred to above to provide:

Specific Engineering Design Structural Components Only
(Extent of Engagement)

services in respect of the requirements of Clause(s) B1, F4 of the Building Code for:

All or Part only (as specified in the attachment to this statement), of the proposed building work.

The design carried out by us has been prepared in accordance with:

Compliance Documents issued by the Ministry of Business, Innovation & Employment Or
B1/VM1; AS/NZS 1170:2021; AS/NZS 1664.1:1997; NZS AS 1720.1:2022; NZS 3101:2006; NZS 3404:1997 (verification method/acceptable solution)

Alternative solution as per the attached schedule.....

The proposed building work covered by this producer statement is described on the report titled:
"PS1 Report - Edgesmith Mercury Balustrade Systems_20.12.24" together with
product manual "Edgesmith Mercury Balustrade Systems_2024 Issue"
together with the specification, and other documents set out in the schedule attached to this statement.

On behalf of the Design Firm, and subject to:

- (i) Site verification of the following design assumptions assumed adequate support structure by others
- (ii) All proprietary products meeting their performance specification requirements;

I believe on reasonable grounds that a) the building, if constructed in accordance with the drawings, specifications, and other documents provided or listed in the attached schedule, will comply with the relevant provisions of the Building Code and that b), the persons who have undertaken the design have the necessary competency to do so. I also recommend the following level of construction monitoring/observation:

CM1 CM2 CM3 CM4 CM5 (Engineering Categories) or as per agreement with owner/developer (Architectural)

I, Kevin Brown am: CPEng # 140404
(Name of Design Professional)

I am a member of: Engineering New Zealand and hold the following qualifications: BE, CMEngNZ, CPEng, IntPE(NZ), MBA...

The Design Firm issuing this statement holds a current policy of Professional Indemnity Insurance no less than \$200,000*.

The Design Firm is a member of ACE New Zealand:

SIGNED BY Kevin Brown (Signature)
(Name of Design Professional)

ON BEHALF OF Lautrec Technology Group Limited Date: 20/12/2024
(Design Firm)

Note: This statement shall only be relied upon by the Building Consent Authority named above. Liability under this statement accrues to the Design Firm only. The total maximum amount of damages payable arising from this statement and all other statements provided to the Building Consent Authority in relation to this building work, whether in contract, tort or otherwise (including negligence), is limited to the sum of \$200,000.*

This form is to accompany **Form 2 of the Building (Forms) Regulations 2004** for the application of a Building Consent.
THIS FORM AND ITS CONDITIONS ARE COPYRIGHT TO ACE NEW ZEALAND AND ENGINEERING NEW ZEALAND



Lautrec Technology Group Ltd.
Professional Consulting Engineers



20/12/2024

To the Building Official,

B2 COMPLIANCE - EDGESMITH MERCURY BALUSTRADE SYSTEMS

at occupancy categories A, B, E, and C3 only; at any location in New Zealand that falls within the scope of this PS1 - see supporting PS1 report for scope

We have been asked to provide a PS1 for Clause B2 of the Building Code - Structural Durability

We are not able to provide this because there is no effective verification method for B2 contained within the New Zealand Building Code.

As these systems can be installed in a variety of settings, including internal and exposed environments, it is not deemed practical to specify durability requirements for the sub structure. Timber treatments, mild steel corrosion protection coatings, and concrete and masonry covers are therefore up to the building designer to specify in accordance with the relevant recognised standards.

However, we can confirm that for the structural elements shown in the attached documentation:

Material	Means of compliance	Details
Edgesmith Mercury Balustrade Systems - Aluminium and Steel	Alternative Solution	Protection for mild steel has been specified in accordance with SNZ TS 3404 - Durability requirements for steel structures and components and AS/NZS 2312 - Guide to the protection of structural steel against atmospheric corrosion by the use of protective coatings. Aluminium extrusions conform to 6063 T5. We note that this is on a time to first maintenance basis.
Connections - Hot Dip Galvanised and Stainless Steel fixings	Alternative Solution	All bolt and screw fixings for the Edgesmith Mercury Balustrade Systems shall be either Hot Dip Galvanised or 304 Stainless Steel. Refer to the fixing table in the Mercury manual.

It is assumed that these structural elements are fixed to adequate structures by others.

Minor tea staining may occur in coastal environments. Refer to Edgesmith Mercury Balustrade Systems manual for the supplier's maintenance requirements.

Yours faithfully,

Managing Director
Kevin Brown
BE, CMEngNZ, CPEng, IntPE(NZ), MBA



Lautrec Technology Group Ltd.
Professional Consulting Engineers



OUTLINE OF COMPLIANCE FOR PARTICULAR ITEMS COMPRISING THE
EDGESMITH MERCURY BALUSTRADE SYSTEMS

Outline of compliance for particular components, NZBC B1

Mild steel sections and aluminium extrusions	Refer to Appendix A3 Calculations - Edgesmith Mercury Balustrade Systems
Coach screws, bolts and concrete anchors	<p>Refer to Appendix A3 Calculations - Edgesmith Mercury Balustrade Systems</p> <p>For fixings to timber, calculations by Juralco outlined within Appendices A3 confirm compliance of fixings to timber.</p> <p>For fixings to concrete, refer to Appendix A3. Concrete is assumed to be min. 20 MPa reinforced concrete (C20), uncracked, and without edge reinforcement.</p> <p>The project engineer shall review and confirm appropriate supporting structure to accommodate loads introduced by the proposed system. Refer to sections within the manual for guidance on installation, and Appendix A3 for loadings of connections back to assumed adequate structure.</p>

Outline of compliance for NZBC B2

All components outlined in the product catalogue shall meet NZBC B2.3.1(b) **15 years**, assuming reasonable maintenance, and appropriate architectural context.

Refer to the Edgesmith Mercury Balustrade Systems manual for maintenance requirements.

Mild steel, Aluminium components, hot dip galvanised or stainless steel 304 fixings are fit for purpose in NZBC corrosion zones C2, C3 and C4. Refer to the product catalogue for more details.

Adequate supporting structure shall be designed by the project designers.

Durability of assumed adequate supporting structure is outside the scope of this PS1.



GENERAL NOTES

- (1) THE BALUSTRADE DRAWINGS ARE TO BE READ IN CONJUNCTION WITH THE ARCHITECT'S AND ENGINEER'S DRAWINGS.
- (2) ALL DIMENSIONS AND LEVELS ARE TO BE CHECKED ON SITE AGAINST THE ARCHITECT'S AND ENGINEERS DRAWINGS PRIOR TO COMMENCING WORK – ANY VARIATIONS OR DISCREPANCIES ARE TO BE REFERRED TO THE CONSULTANT FOR RESOLUTION.
- (3) THE EXISTING SUPPORTING STRUCTURE DETAILS ARE NOT COVERED BY THESE DRAWINGS. IT IS ASSUMED THAT THE EXISTING SUPPORT STRUCTURE CAN ACCOMMODATE THE ADDITIONAL LOADS INDUCED BY THE BARRIER. IN ADDITION, THE EXISTING STRUCTURE MUST HAVE THE REQUIRED MINIMUM PROPERTIES AS FOLLOWS: $f_c = 20$ MPa (FOR CONCRETE), $f_m = 12$ MPa (FOR MASONRY), GROUP J5 MATERIAL (FOR TIMBER).
- (4) THESE DRAWINGS ONLY COVER THE INSTALLATION/CONNECTION DETAILS OF THE MERCURY COMMERCIAL BALUSTRADE SYSTEM.
- (5) A MINIMUM OF 48 HOURS NOTICE IS REQUIRED FOR ANY CONSTRUCTION MONITORING OBSERVATIONS. A PS4 CANNOT BE PROVIDED (PRODUCER STATEMENT CONSTRUCTION REVIEW), IF THE CONSULTANT IS NOT INFORMED OF THE REQUIRED INSPECTIONS THAT THE LOCAL TERRITORIAL AUTHORITY MAY REQUIRE.
- (6) REMOVE ALL EXCESS MATERIALS AND RUBBISH FROM SITE AND REINSTATE ANY DAMAGE ON COMPLETION OF WORKS.
- (7) ALL DAMAGE TO EXISTING STRUCTURE CAUSED BY CONSTRUCTION ARE TO BE REINSTATED.
- (8) ALL WORKS ARE TO COMPLY WITH THE NEW ZEALAND BUILDING CODE (NZBC).

DURABILITY – STEEL FIXINGS & COMPONENTS

- (9) HOT-DIPPED GALVANIZED BOLTS/FIXINGS CAN BE USED FOR LOCATIONS THAT FALL UNDER TYPICAL ATMOSPHERIC CATEGORIES B & C SO LONG AS THE MAINTENANCE PROGRAM AS DETAILED FOR THE DESIGN IS STRICTLY ADHERED TO. REFER TO TABLE 1 & 2 BELOW.
- (10) GRADE 304 STAINLESS STEEL BOLTS/FIXINGS ARE TO BE USED FOR LOCATIONS THAT FALL UNDER TYPICAL ATMOSPHERIC CATEGORY D OR IN CATEGORY C LOCATIONS WHERE ITEMS ARE DEEMED TO BE SHELTERED AND UNABLE TO BE WASHED REGULARLY AS REQUIRED BY THE MAINTENANCE PLAN. REFER TO TABLE 1 & 2 BELOW.
- (11) FOR FIXINGS REQUIRED IN AREAS OF TYPICAL ATMOSPHERIC CATEGORIES OTHER THAN B, C & D, OR IN WET LOCATIONS WHERE STEEL WILL REMAIN WET FOR EXTENDED PERIODS OF TIME, SUCH AS CREVICES, LOW POINTS & POCKETS NOT DRAINED, THESE WILL REQUIRE SPECIFIC ENGINEERING DESIGN (SED) WHERE MORE DURABLE GRADE 316 OR HIGHER STAINLESS STEEL OR SILICON BRONZE FIXINGS MAYBE MORE SUITABLE. REFER TO TABLE 1 & 2 BELOW.
- (12) FOR FIXINGS AND COMPONENTS THAT ARE TO HAVE DIRECT CONTACT WITH PRESERVED TIMBER (PT), ESPECIALLY WHEN THE PRESERVATIVE TREATMENT USES COPPER AZOLE-BASED (CuAz) OR ALKALINE COPPER QUATERNARY-BASED (ACQ) PRESERVATIVES AND A HIGH TIMBER MOISTURE CONTENT IS EXPECTED, THEN GRADE 304/316 STAINLESS STEEL FIXINGS ARE RECOMMENDED. IF GALVANIZED FIXINGS ARE USED WHERE MOISTURE CONTENT OF THE PRESERVED TIMBER (PT) WAS EXPECTED TO BE LOW BUT SUBSEQUENTLY FOUND TO BE HIGH THEN THEIR INSPECTION SHOULD BE CARRIED OUT REGULARLY AS PART OF THE MAINTENANCE PROGRAM. THIS WOULD INVOLVE REMOVING ANY HIGH-RISK COMPONENTS SUCH BOLTS OR COACH SCREWS FIXED INTO OBVIOUS DAMP AND WET TIMBERS WHICH MAY OR MAY NOT BE CLOSE TO THE GROUND OR EVEN HIGHER THAN 600MM FROM THE GROUND. THE EMBEDDED THREAD AND SHAFT NEEDS TO BE REMOVED AND INSPECTED CLOSELY AT MINIMUM 5 YEARLY INTERVALS. IF SIGNS OF CORROSION ARE FOUND ON OVER 1%-2% OF THE SURFACE AREA THEN THE FIXING IS TO BE REPLACED WITH A STAINLESS-STEEL EQUIVALENT OR A GALVANIZED BOLT WITH ADDITIONAL SURFACE PROTECTION WHILE CONTINUING THE SAME MAINTENANCE PROGRAM TO MONITOR OR UNTIL SATISFACTORY. IN SOME SPECIFIC ENGINEERING DESIGN (SED) CASES, MORE DURABLE MATERIALS SUCH AS SILICON BRONZE MAYBE REQUIRED.
- (13) PREVENT CONTACT BETWEEN ALL DISSIMILAR MATERIALS (i.e. GALVANIZED STEEL AND ALUMINIUM OR GALVANIZED STEEL AND STAINLESS STEEL) BY SEPARATING WITH NEOPRENE WASHERS OR SIMILAR APPROVED.
- (14) ALL CHEMSET CONCRETE ANCHORS ARE TO BE FIXED TO MANUFACTURER'S SPECIFICATIONS.

TABLE 1: TYPICAL ATMOSPHERIC CATEGORY

ENVIRONMENT LIMITATIONS	MACROCLIMATE CORROSION CATEGORY (SNZ TS 3404:2018 & AS/NZS 2312.1:2014)
MORE THAN 20KM TO 50KM FROM SALT WATER ON WEST & SOUTH COAST OF SOUTH ISLAND, 5KM TO 50KM FROM SALT WATER ON EAST COAST OF BOTH ISLANDS & SOUTH COASTS OF NORTH ISLAND & ALL HARBOURS OR OTHERWISE INLAND MORE THAN 50KM.	C2
WITHIN 20KM OF BREAKING SURF ALONG THE WEST & SOUTH COASTS OF SOUTH ISLAND, OR WITHIN 5KM OF SALT WATER ALONG EAST COAST OF BOTH ISLANDS, OR WITHIN 5KM OF SALT WATER WEST & SOUTH COASTS OF THE NORTH ISLAND, & ALL HARBOURS.	C3
WITHIN 500M INLAND OF BREAKING SURF, OR WITHIN 50M OF CALM SALT WATER SUCH AS HARBOUR FORSHORES. THIS AREA MAY BE EXTENDED INLAND BY PREVAILING WINDS AND LOCAL CONDITIONS.	C4
WITHIN 200M OF BREAKING SURF ON THE WEST AND SOUTH COASTS OF THE SOUTH ISLAND, OR WITHIN 100M OF BREAKING SURF ON THE WEST AND SOUTH COASTS OF THE NORTH ISLAND, OR WITHIN 50M OF BREAKING SURF ON ALL OTHER COASTS, OR WITHIN 500M OF GEOTHERMAL SOURCE OR WITHIN SPACES OF HIGH HUMIDITY OR CORROSIVE ENVIRONMENTS. CONTACT YOUR SUPPLIER/ENGINEER FOR MORE GUIDANCE.	SED C5-I, C5-M, CX/T

NOTE 1: ABOVE ENVIRONMENTS MAY BE EXTENDED INLAND BY PREVAILING WINDS & LOCAL CONDITIONS.

REFER TO SNZ TS 3404:2018 FIGURES 1 TO 7 FOR SPECIFIC CORROSION MAPS FOR FURTHER GUIDANCE. FOR CONFIRMATION OF A SITE-SPECIFIC ATMOSPHERIC CORROSION CATEGORY (FOR EXAMPLE, FOR SITES THAT ARE SHELTERED FROM MARINE INFLUENCE BY THE LOCAL TOPOGRAPHY), THEN SITE-SPECIFIC TESTING CAN BE CARRIED OUT AS DESCRIBED IN HERA REPORT R4-133.

TABLE 2: DURABILITY PROVISION

TYPICAL ATMOSPHERIC CATEGORY	C4	C3	C2	ALL OTHERS
EXPOSED (NOTE 2)	ALL FIXINGS TYPE 304SS	HOT DIPPED GALVANIZED STEEL	HOT DIPPED GALVANIZED STEEL	SED
SHELTERED (NOTE 2)	ALL FIXINGS TYPE 304SS	ALL FIXINGS TYPE 304SS	HOT DIPPED GALVANIZED STEEL	SED

NOTE 2: REFER TO SNZ TS 3404:2018 FOR DEFINITION OF "SHELTERED" & "EXPOSED". WHERE ITEMS ARE IN SHELTERED LOCATIONS THESE CAN BE TREATED AS EXPOSED IF REGULAR WASHING DOWN IS CARRIED OUT AS PART OF THE REGULAR MAINTENANCE PROGRAM.



Side Fix to Timber Retaining Wall - Commercial

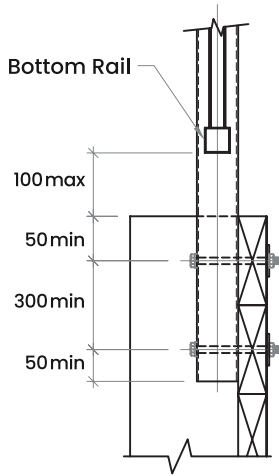

Post: PBS-2.0-2CTR

Option 1 - Bolt:

2 x M10 (min.) with 50 x 50 x 4 mm sq washer on timber side.

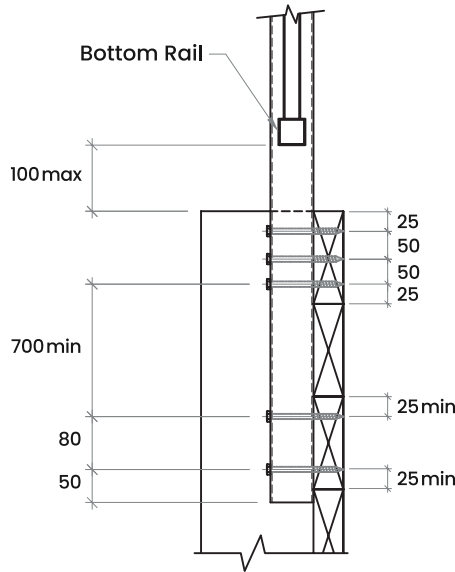

Steel Post: PBS-2.4-5CTR-GPCB or PBS-2.4-5CTR-GPC

Option 2 - Coach Screws:

5 x M10, min 50 mm penetration into timber.

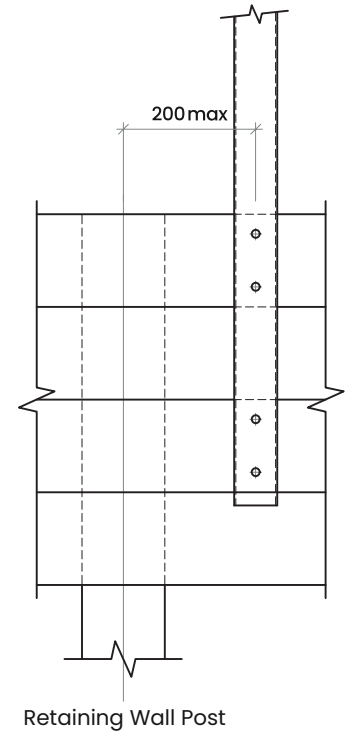

Concreted in ground - Commercial

Note:

Post footing to be embedded in good ground with min 100kPa allowable bearing as defined by NZS 3604:2001

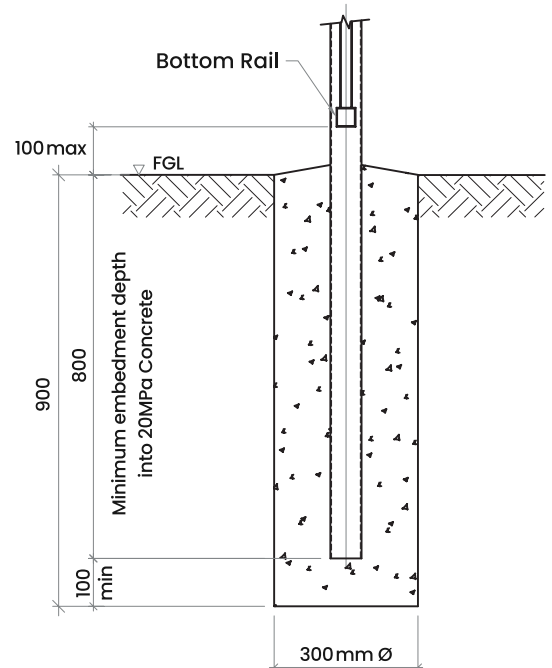

Post Details for Balustrade - Commercial

Zone Class	Loading	Panels	Posts	Fasteners
B, E, C3 School, Park, Multi- Dwelling Residential, Commercial	0.75kN/m	Mercury Commercial, Chief MK2	65shs x 2.5mm Steel Post centers 2.4m	<500m from sea - 304SS, >500m from sea - 304SS or HDG



Top Fix to Concrete Post centers 2.4m

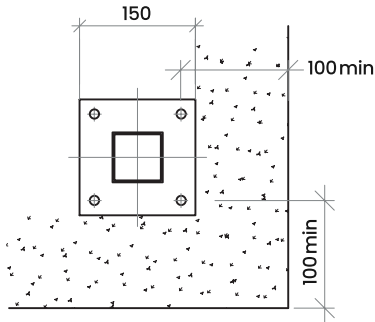

Option 1 - Screw Bolts:

4 x M12 fischer bolt anchor FBN II or equivalent, 65 mm min embedment into 20 MPa uncracked concrete.

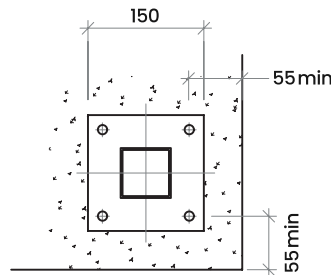

Option 2 - Chemset Rod:

4 x M12 threaded rod with fischer FIS V or equivalent, 75 mm min embedment into 20 MPa uncracked concrete.

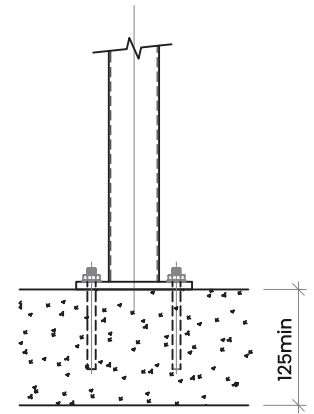

Side Fix to Block Wall

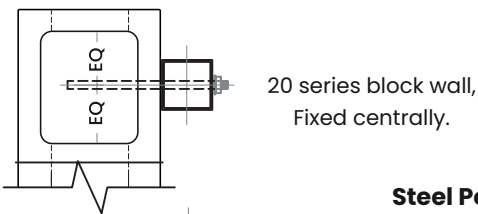

20 series block wall,
Fixed centrally.

Steel Post:

PBS-1.9-2MB-GPCB
or PBS-1.9-2MB-GPC

Chemset Rod:

Post centers 2.4m
2 x M12 threaded rod
with fischer FIS V or
equivalent, 70mm min
into masonry core,
fully grouted 20 MPa.

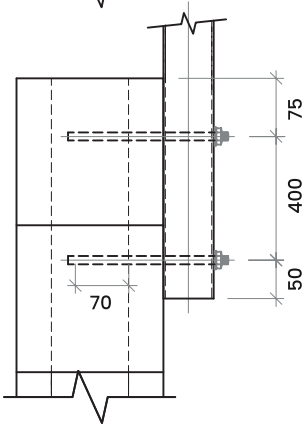

Side Fix to Concrete

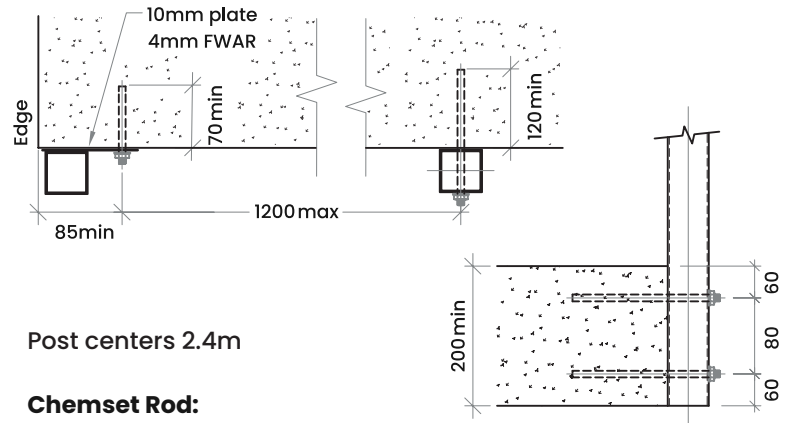

Post centers 2.4m

Chemset Rod:

For typical/intermediate balustrade posts:
2 x M12 threaded rod with fischer FIS V or equivalent, 120 mm min.
anchorage depth into 20 MPa concrete.

For end balustrade posts:
2 x M12 threaded rod with fischer FIS V or equivalent, 70 mm min.
anchorage depth into 20 MPa concrete, ensure 85 mm min. side edge
distance.

Top Fix to Block Wall

Chemset Rod: Post centers 1.2m

22 x M12 threaded rod with fischer FIS V or equivalent, 70 mm min
embedment into masonry core, fully grouted 20 MPa,
ensure 55 mm min. side edge distance.

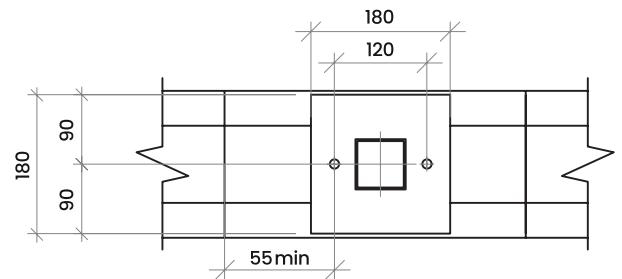

Post Details for Balustrade - Commercial and Residential

Zone Class	Loading	Panels	Posts	Fasteners
B, E, C3 Parks, Schools, Multi- Dwelling Residential, Commercial	0.75kN/m	Mercury Commercial, Chief-MK2	65shs x 2.5mm Steel 10mm thick flange Post centers varies	<500m from sea - 304SS, >500m from sea - 304SS or HDG



Top Fix to Timber Deck - Residential

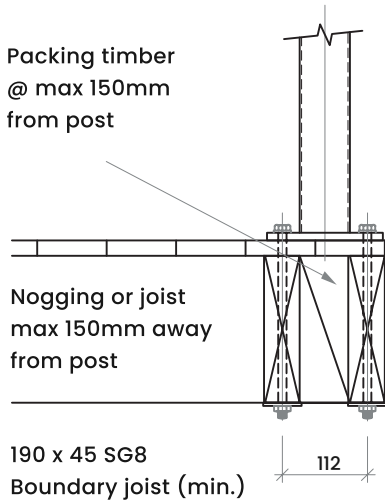

Post: PF1.3x65x2.5 (Steel) or PAF1.3x65x2.5-PC (Alu)

Option 1 - Bolts:

4 x M10 with 50 x 50x 4mm sq washer on timber side.

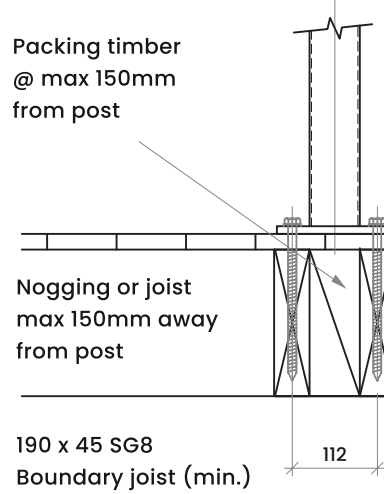

Post: PF1.3x65x2.5 (Steel) or PAF1.3x65x2.5-PC (Alu)

Option 2 - Coach Screws:

4 x M10, min 160 mm penetration into timber.

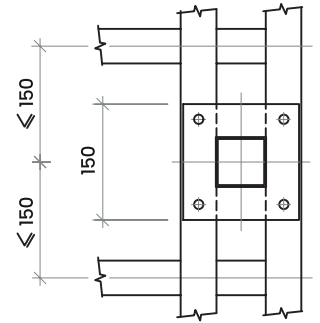

Side Fix to Timber Deck - Residential

Bolts:

2 x M10 (min.) with 50 x 50 x 4 mm sq washer on timber side.

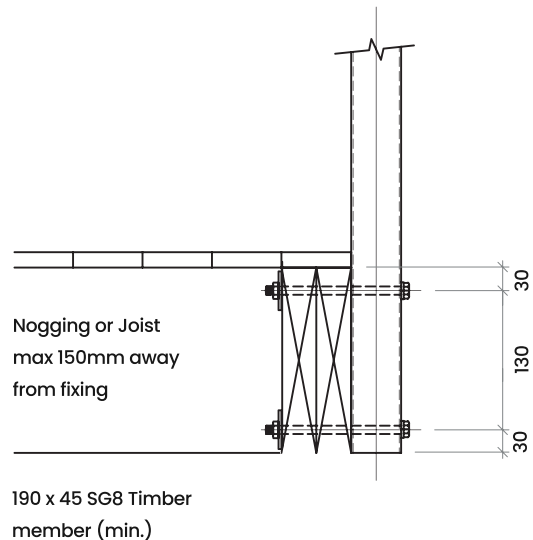

Deck Designed by Others

Post Details for Balustrade - Residential

Zone Class	Loading	Panels	Posts	Fasteners
A Single Dwelling Residential	0.75kN/m	Mercury Commercial or Residential	65shs x 2.5mm Steel or 65shs x 2.5 mm 6063-T5, 150x10mm Flange Post centers 1.2m	<500m from sea - 304SS, >500m from sea - 304SS or HDG



Side Fix to Timber Retaining Wall - Residential

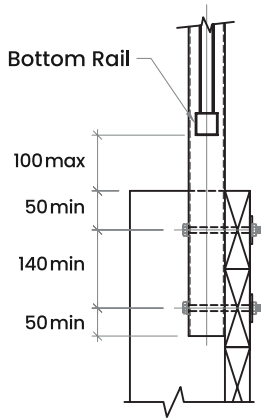

Post: PBS-1.8-2RTR (Steel) or PBA-1.8-2RTR (Alu)

Option 1 - Bolts:

2xM10 with 50x50x4mm sq washer on timber side.

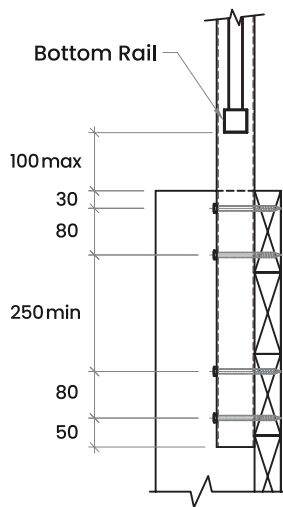

Post: PBS-2.0-4RTR (Steel) or PBA-2.0-4RTR (Alu)

Option 2 - Coach Screws:

4xM12, min 50mm penetration into timber.

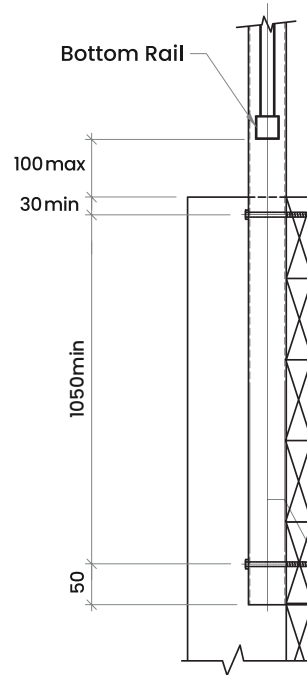

Option 3 - Coach Screws:

2xM12, min 50mm penetration into timber.

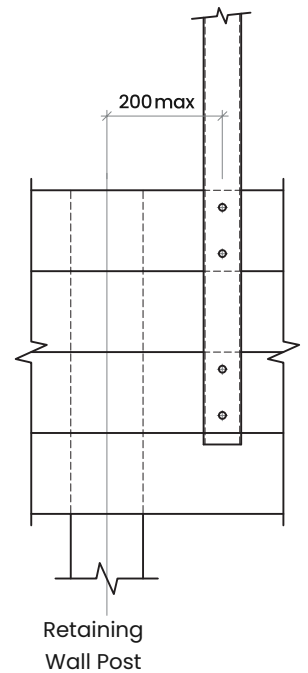

Post: PBS-2.5-2RTR (Steel) or PBA-2.5-2RTR (Alu)

Concreted in ground - Residential (drawing SK-01 S04)

Note:

Post footing to be embedded in good ground with min 100kPa allowable bearing as defined by NZS 3604:2001

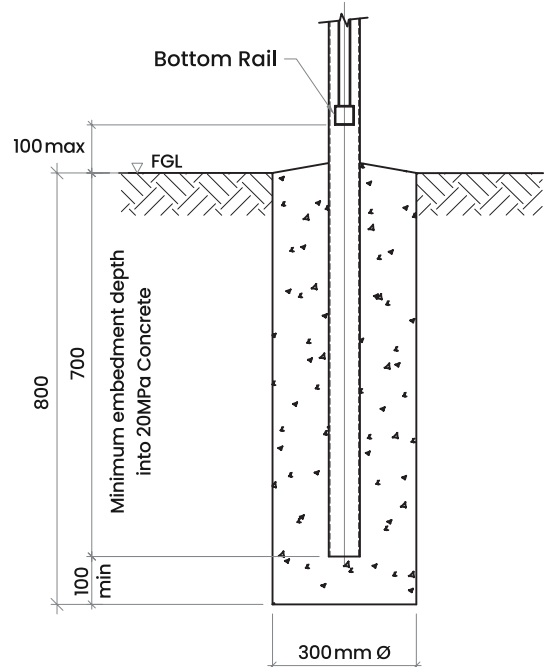

Post Details for Balustrade - Residential

Zone Class	Loading	Panels	Posts	Fasteners
A Single Dwelling Residential	0.35kN/m	Mercury Commercial or Residential	65shs x 2.5mm Steel, 65shs x 2.5 mm 6063-T5 Alu Post centers 2.4m	<500m from sea - 304SS, >500m from sea - 304SS or HDG



North Auckland Branch

20 Anvil Road, Silverdale
Auckland 0932

Contact

T: 09 427 4980
E: crew@edgesmith.co.nz

South Auckland Branch

20 Kerwyn Avenue, East Tamaki
Auckland 2013

Monday - Friday:
8.00am - 4.30pm

Christchurch Branch

4 Anchorage Road, Hornby,
Christchurch 8042