

Bill of Materials (BOM)			
Item	Title	Material	Qty.
1	Kaweka Spigot	2205 SS	1
2	Kaweka Cover Plate	2205 SS	1
3	Kaweka Insert	2205 SS	1
4	M4x6 CSK CAP	316 SS	1
5	KAWEKA INSERT	ABS	1
6	KAWEKA LOAD PLATE	AISI 304	1
7	M10x12 Grub Screw	EDST	2

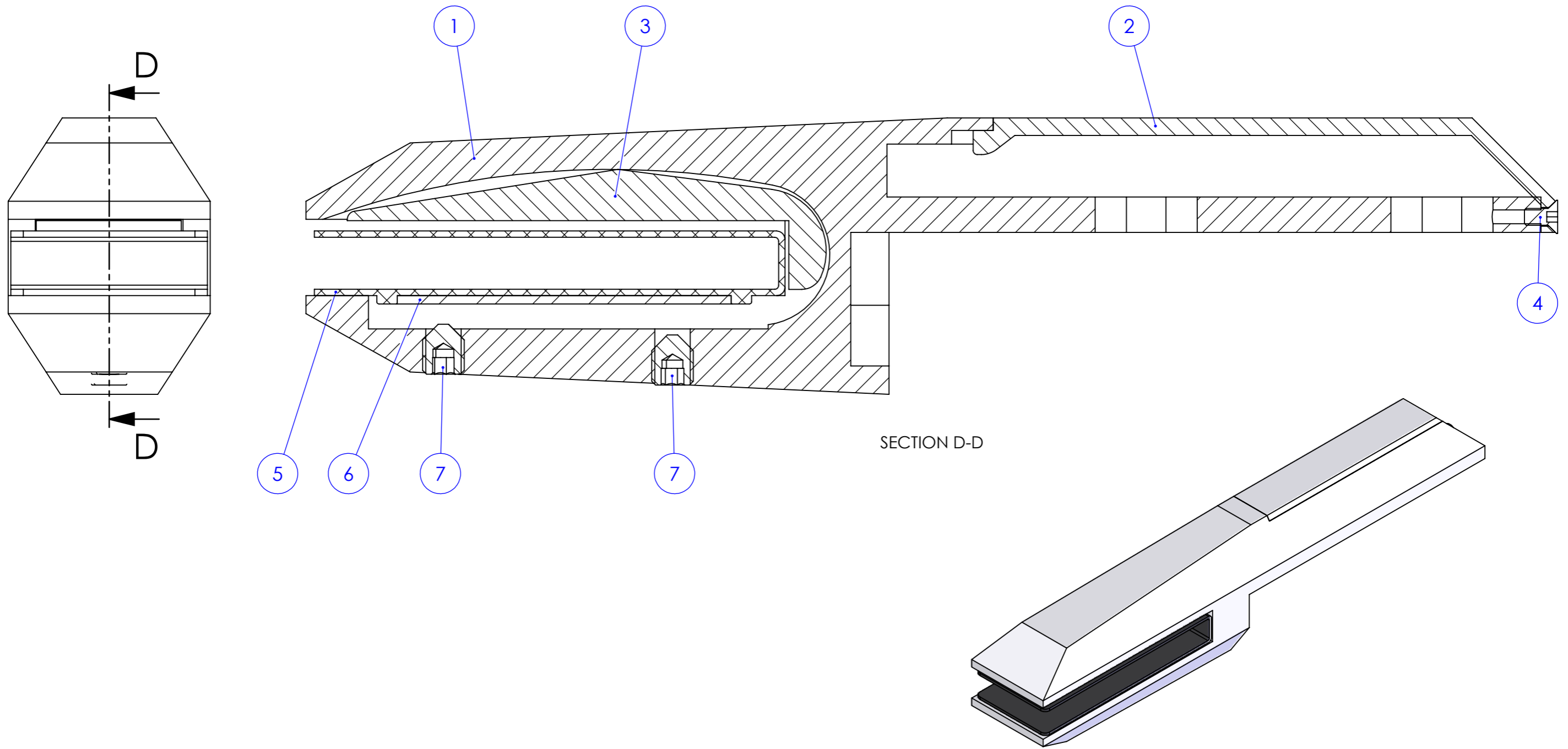

TOLERANCES 0 ±0.5mm 0.0 ±0.1mm 0.00 ±0.02mm ANGLE ±0.5° UNLESS OTHERWISE STATED	THE INFORMATION CONTAINED IN THIS DRAWING IS PROPRIETARY TO STORETECH AND SHALL NOT BE REPRODUCED OR DISCLOSED IN WHOLE OR IN PART OR USED FOR ANY DESIGN OR MANUFACTURE EXCEPT WHEN SUCH USER POSSESSES DIRECT WRITTEN AUTHORIZATION FROM STORETECH LTD.	DRAWN BY: MvB	DATE: 17/01/2021	NOTES: Note1 Note2 Note3 Note4 Note5 Note6	MATERIAL: as per constituents	PHASE:	DESCRIPTION: SCALE: 1:1 SHEET: A3 SHEET: 1 OF 3 PART NUMBER: REVISION:
		CHECKED BY:	3RD ANGLE PROJECTION		FINISH:	PROCESS:	
		DIMENSIONS ARE MILLIMETERS UNLESS OTHERWISE STATED. DO NOT SCALE DRAWING.			TYPE:		



SECTION D-D



TOLERANCES	
0	±0.5mm
0.0	±0.1mm
0.00	±0.02mm
ANGLE	±0.5°
UNLESS OTHERWISE STATED	

THE INFORMATION CONTAINED IN THIS DRAWING IS PROPRIETARY TO STORETECH AND SHALL NOT BE REPRODUCED OR DISCLOSED IN WHOLE OR IN PART OR USED FOR ANY DESIGN OR MANUFACTURE EXCEPT WHEN SUCH USER POSSESSES DIRECT WRITTEN AUTHORIZATION FROM STORETECH LTD.

DRAWN BY: MvB	DATE: 17/01/2021
CHECKED BY:	3RD ANGLE PROJECTION
DIMENSIONS ARE MILLIMETERS UNLESS OTHERWISE STATED. DO NOT SCALE DRAWING.	

NOTES:
 Note1
 Note2
 Note3
 Note4
 Note5
 Note6

MATERIAL: as per constituents	PHASE:
FINISH:	PROCESS:
	TYPE:

DESCRIPTION:				
SCALE: 1:1	SHEET: A3	SHEET: 2 OF 3	PART NUMBER:	REVISION:

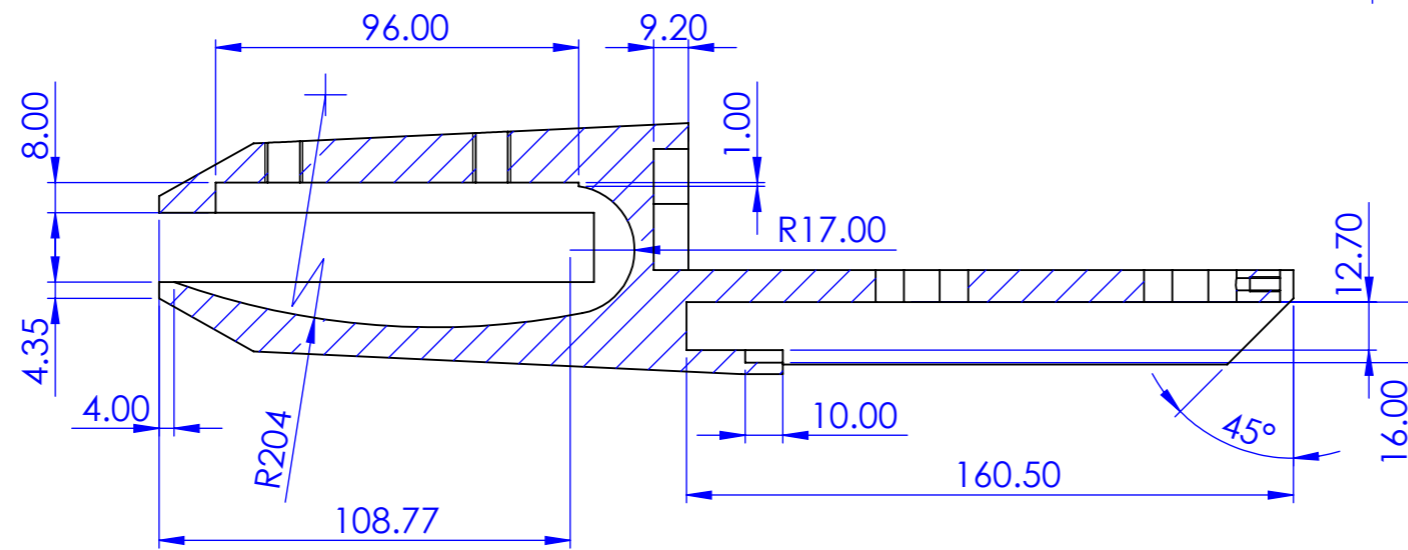
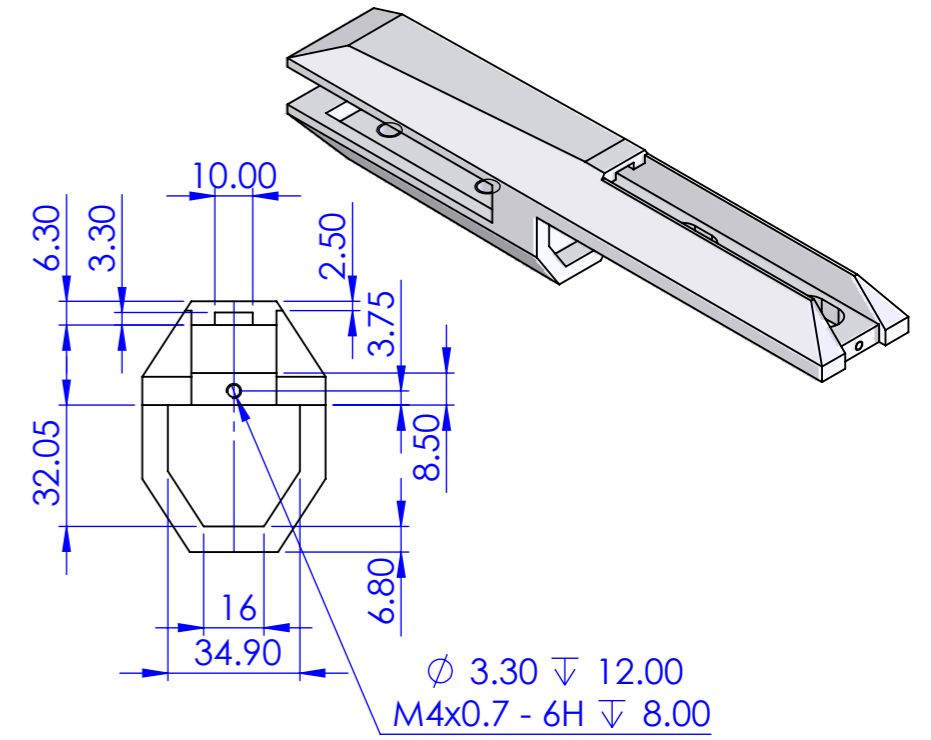
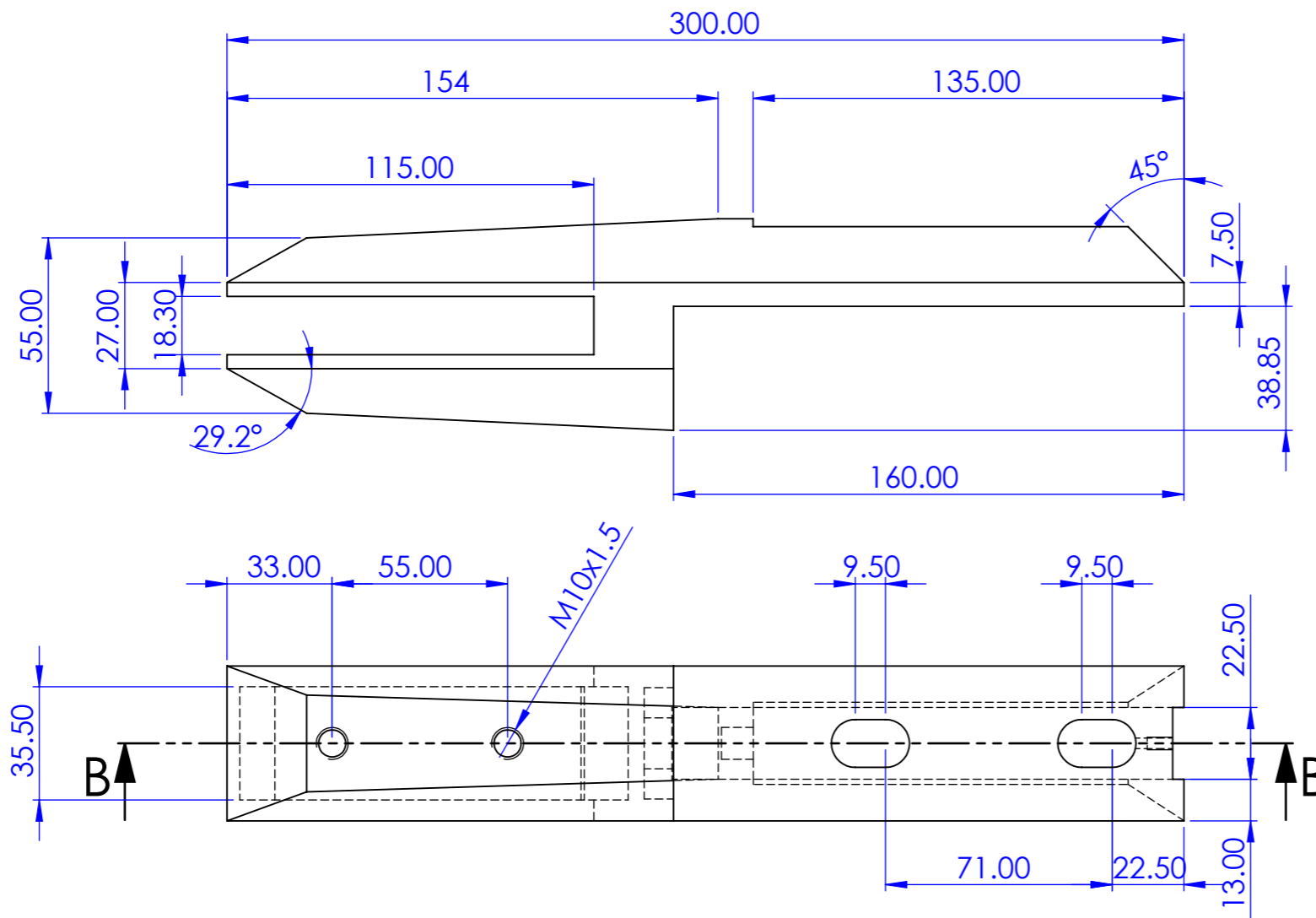
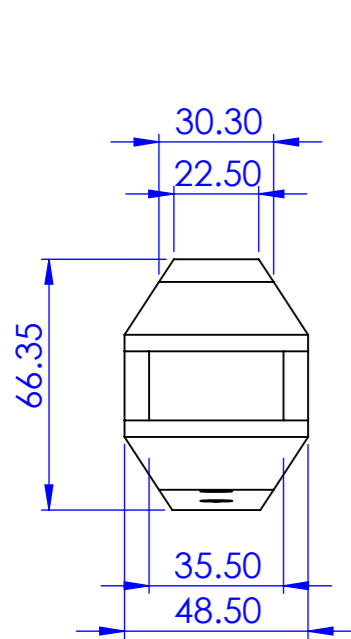

SECTION B-B



TOLERANCES 0 ±0.5mm 0.0 ±0.1mm 0.00 ±0.02mm ANGLE ±0.5° UNLESS OTHERWISE STATED	THE INFORMATION CONTAINED IN THIS DRAWING IS PROPRIETARY TO STORETECH AND SHALL NOT BE REPRODUCED OR DISCLOSED IN WHOLE OR IN PART OR USED FOR ANY DESIGN OR MANUFACTURE EXCEPT WHEN SUCH USER POSSESSES DIRECT WRITTEN AUTHORIZATION FROM STORETECH LTD.	DRAWN BY: MvB	DATE: 17/01/2021	NOTES: Note1 Note2 Note3 Note4 Note5 Note6	MATERIAL: as per constituents	PHASE:	DESCRIPTION: ...make it your own!			
		CHECKED BY:	3RD ANGLE PROJECTION		FINISH:	PROCESS:				
DIMENSIONS ARE MILLIMETERS UNLESS OTHERWISE STATED. DO NOT SCALE DRAWING.					TYPE:	SCALE: 1:2	SHEET: A3	SHEET: 3 OF 3	PART NUMBER:	REVISION: