

DOMESTIC, RESIDENTIAL & NON RESIDENTIAL GLASS INFILL BALUSTRADES COVERING OCCUPANCIES A, B, C3 & E OF TABLE AS/NZS 1170.1:2002 UP TO A MAXIMUM HEIGHT OF 2000MM ABOVE THE TOP FIXING.

BALUSTRADE GLASS - 10MM & 12MM TOUGHENED OR 12MM TOUGHENED LAMINATE.

LAMINATE INTERLAYER NOT INCLUDED IN GLASS THICKNESS.

POOL FENCING - 12MM TOUGHENED, OR 12MM TOUGHENED LAMINATE TO A MAXIMUM HEIGHT OF 2000MM ABOVE GROUND LEVEL

MAXIMUM POST CENTERS WITH OR WITHOUT HANDRAIL

INTERIOR BALUSTRADE

REFER OPUS TECHNICAL DRAWING OB100/24

EXTERIOR BALUSTRADE

REFER OPUS TECHNICAL DRAWING OB100/24

POOL FENCE MINIMUM HEIGHT OF 1200MM ABOVE G.L PLEASE NOTE: POOL FENCING SUBJECT TO ULS LOADS EXCEEDING 1.76KPa TO 2.1KPa POST TO BE INSTALLED AT-

REFER OPUS TECHNICAL DRAWING OB100/24

COMMERCIAL AND OFFICES WITHOUT CROWDING, RETAIL, RESTAURANTS & BARS COVERING OCCUPANCIES C1, C2 & D OF TABLE AS/NZS 1170.1:2002 UP TO A MAXIMUM HEIGHT OF 2000MM ABOVE THE TOP FIXING.

BALUSTRADE GLASS - 15MM TOUGHENED OR 16MM TOUGHENED LAMINATE.

LAMINATE INTERLAYER NOT INCLUDED IN GLASS THICKNESS.

MAXIMUM POST CENTERS WITH OR WITHOUT OPTIONAL HANDRAIL

INTERIOR BALUSTRADE

REFER OPUS TECHNICAL DRAWING OB100/24

EXTERIOR BALUSTRADE

REFER OPUS TECHNICAL DRAWING OB100/24

NOTES:

TIMBER/STEEL CALCULATIONS ARE THE RESPONSIBILITY OF OTHERS.

ALL FIXING HARDWARE TO BE GRADE 316 STAINLESS STEEL.

DURATEC POWDERCOAT OR 25 MICRON ANODISED FINISH IS RECOMMENDED FOR ALL INSTALLATIONS ESPECIALLY WITHIN COASTAL AREAS.

THIS PROPRIETARY BALUSTRADE SYSTEM HAS BEEN DESIGNED IN CONJUNCTION WITH THE GANZ BALUSTRADE DESIGN TABLE SB-3 AND COMPLIES WITH THE NEW ZEALAND BUILDING CODE CLAUSES B1 STRUCTURAL, B2 DURABILITY, F2 HAZARDOUS BUILDING MATERIALS AND F4 SAFETY FROM FALLING THIRD ADDITION, SUBJECT TO:

- ALL PRODUCTS MEETING THEIR PERFORMANCE SPECIFICATION.
- INSTALLATIONS MUST BE IN ACCORDANCE WITH THE INTENT OF THIS DRAWING AND COMPLY WITH NZS 4223.3:2016 REQUIREMENTS

THE GANZ TABLE SB-3 ALLOWS A MAXIMUM ULS OF 2.1KPa AND SLS OF 1.5KPa DESIGN WIND PRESSURE FOR THE LOCATION AND IF THE SITE DESIGN WIND PRESSURE EXCEEDS THESE, SPECIFIC DESIGN IS REQUIRED TO DETERMINE THE GLASS THICKNESS.

THE DESIGN HAS BEEN VERIFIED BY AN INDEPENDENT ENGINEERING CONSULTANT AND A PRODUCER STATEMENT PS1 DESIGN IS AVAILABLE.

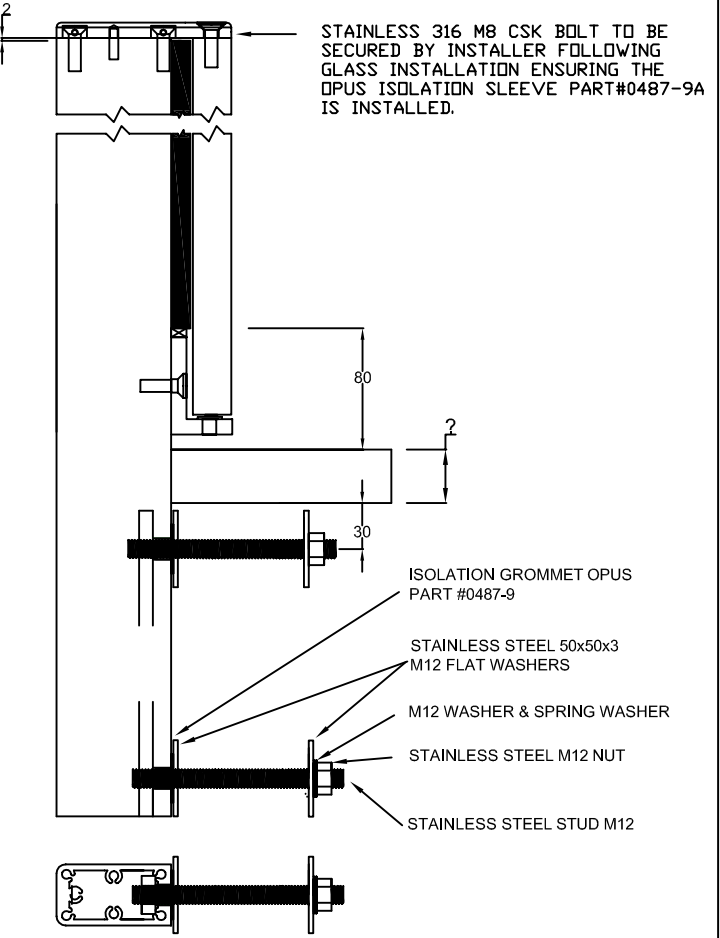
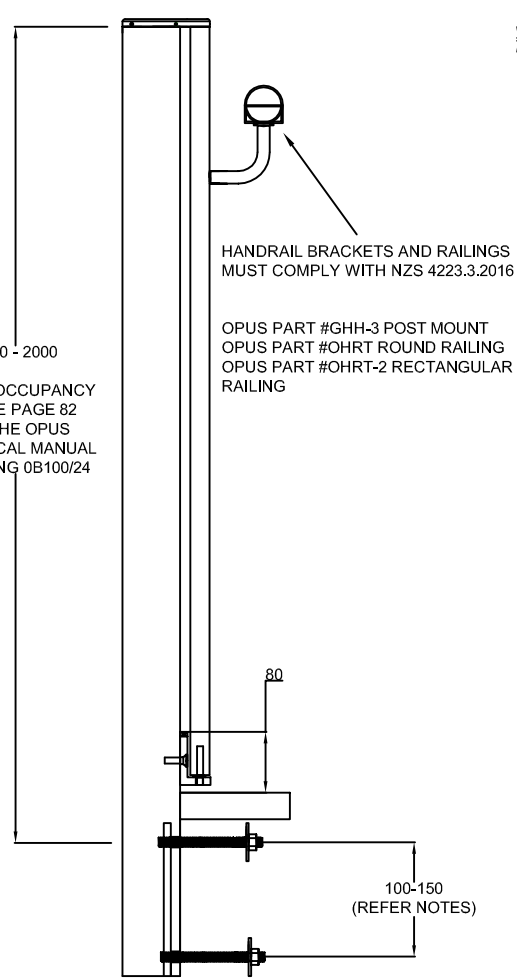

TIMBER/STEEL BY OTHERS

THIS POST IS PROTECTED BY NZ DESIGN APPLICATION NO 416723

DRAWING UPDATED 19/05/16 TO INCLUDE NZS 4223.3:2016 REQUIREMENTS
DRAWING UPDATED 29/11/17 TO INCLUDE GLASS TYPES

OPUS™ MANUFACTURING LTD.
11 Grasslands Place
P.O.Box 5750 Frankton, Hamilton, New Zealand
Telephone: +64 7 847 5001
Fax: +64 7 847 5003

OPUS SEMI - FRAMELESS BALUSTRADE POST OB101-C SHOWING RECOMMENDED FIXING FOR FACE FIX TIMBER/STEEL

© OPUS MANUFACTURING LTD 2012

DRAWING NUMBER: OB100/4
TECHNICAL MANUAL PAGE 81C