

RETROFIT UNDERFLOOR WOOL INSULATION



TERRA LANA

PRODUCT DATA

The superior natural benefits of Terra Lana Wool insulation designed for underfloors

APPLICATIONS

- Suspended floors, installed from the underside where there is a minimum 350mm clearance between the bearer and ground.
- Retrofit under existing floors only
- Residential and commercial buildings

FEATURES

- Designed to not slump or lose loft
- Superior insulative performance
- 100% recyclable (by Terra Lana)
- Easy to install, manufactured to fit
- Environmentally responsible product
- Naturally safe to handle & healthy in the home
- Manages moisture, maintaining thermal performance
- Excellent acoustic barrier qualities

DESCRIPTION

Designed to fill existing underfloor cavities with a durable, semi-rigid, high performance wool composition that is easy to install. The rigid structure prevents sagging, air movement and heat loss through gaps. The wool component transmits moisture vapour away from the building and maintains effectiveness in humid or damp conditions.

COMPLIANCE

- BRANZ APPRAISED. Appraisal 682 [2022]
- DECLARE RED LIST FREE. Certified toxin free
- GREENGUARD. Indoor air quality test approved
- HOMESTAR/GREENSTAR. Credits available
- EPD (in process for mid 2024 completion)
- QUALITY ASSURANCE. 50 year warranty

SPEC ASSIST

- Masterspec
- Smart Spec
- Design Navigator
- H1 Reports & spec writing

Contact: spec@terralana.co.nz

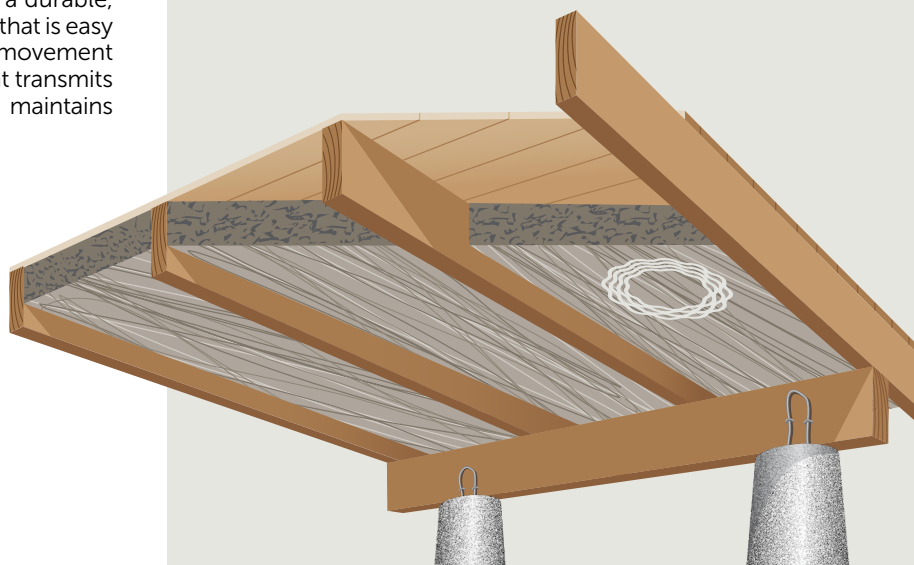

SPECIFICATIONS

R-VALUE	THICKNESS	CENTRES	BALE CONTAINS	M ² PER BALE	CODE
UNDERFLOOR INSULATION					
R2.0	115mm	450mm	2 x 5.6m x 480mm	5.38 m ²	20.115.480



0800 485 262 | sales@terralana.co.nz | terralana.co.nz