

# Architects Guide to Central Heating



# Contents

---

Benefits Of Hydronic Central Heating & Cooling Systems: .....	2
Component Life Expectancy: .....	2
Reduced Refrigerant Risk: .....	3
Reduced Operating Costs: .....	4
Improved Comfort:.....	6
Improved System Efficiency:.....	8
Central Heating Compliance with H1:.....	9
Heated Floor Compliance: .....	9
Heated Ceiling & Walls: .....	11
Product Specification Guide: .....	13
Underfloor Installation Methods .....	13
Tying-to-mesh: .....	14
Clipping to insulation: .....	15
Variocomp .....	16
Spreader Plates .....	17
Floor covering temperature Detail.....	18
Underfloor Manifold Cabinet Locations .....	19
Module Panels: .....	20
Radiators:.....	24
Hot Water Cylinders: .....	26
DHW Heating for Larger Homes: .....	29
Heat Pump Clearance Requirements .....	32
Thermostat Placement: .....	34
Controls Guidelines:.....	35



# Benefits Of Hydronic Central Heating & Cooling Systems

## Component Life Expectancy

Unlike other heating and cooling systems, Central Heating New Zealand's radiant heating and cooling solutions utilise products and installation techniques that allow systems to have very long-life expectancies.

When prospective customers are comparing central heating systems to other options often the initial concern is the additional capital cost of these systems, when the life expectancy and cost over the life of the building is taken into consideration these systems have very similar costs.

The table below shows the minimum life expectancy in the dark columns with the faded columns showing the actual life expectancy of some common forced air based and central heating-based components:

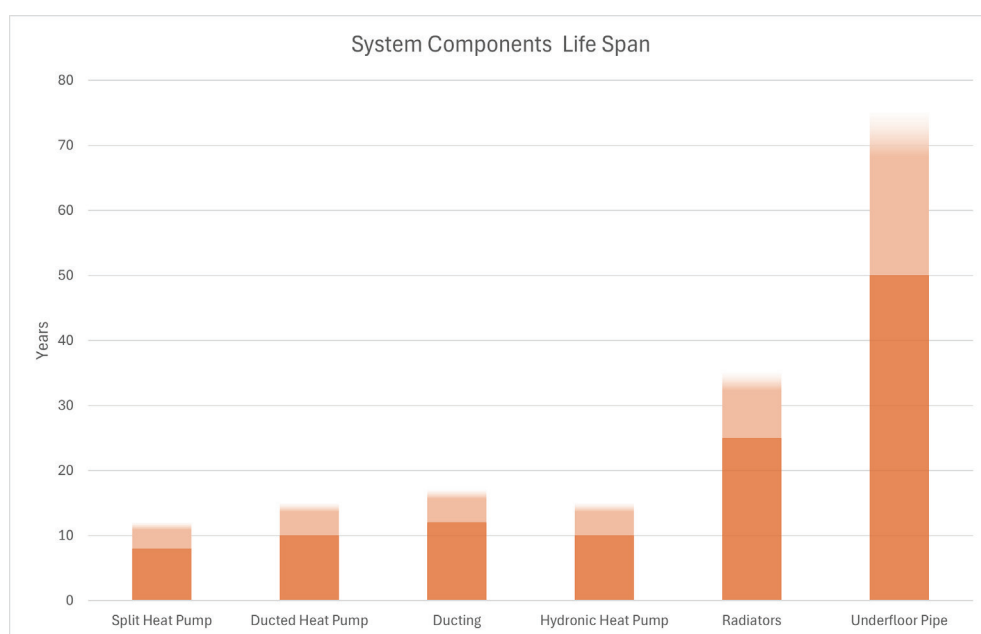

## Reduced Refrigerant Risk

Monoblock air-to-water heat pumps require less refrigerant compared to traditional systems due to their closed-loop design. In traditional systems, the refrigerant directly heats the building space, necessitating a larger amount of refrigerant to circulate throughout the entire system. In contrast, the monoblock air to water heat pumps supplied by Central heating New Zealand combine the indoor and outdoor units, employing a closed refrigerant loop. This loop allows the refrigerant to absorb heat from the air outside, then transfer it to a separate water loop all within the outside unit. This water is then circulated throughout the building, distributing the heat to the various emitters. This separation allows for a smaller amount of refrigerant confined within the outdoor unit, minimizing environmental impact, and creating a safe home for occupants.

Additionally, with the future introduction of R290 refrigerant the benefits are greater still. R290 (also known as propane), is a natural refrigerant with a very low Global Warming Potential (GWP) of 3, significantly reducing the environmental impact compared to traditional refrigerants with much higher GWPs. The closed-loop design of the Monoblock system minimizes the amount of R290 required, further reducing the potential impact of any leaks.

The lower volume of refrigerant in Central Heating New Zealand's Monoblock Air-to-Water Heat pumps offer two main benefits for both the environment and the occupants of the building.

- **Reduced Emissions:** In traditional systems, a larger volume of refrigerant circulates throughout the system, increasing the risk of leaks that can release harmful refrigerants into the atmosphere, contributing to the greenhouse gas effect. By using a closed-loop design with a smaller refrigerant volume, air-to-water heat pumps reduce the likelihood of leaks, consequently reducing overall greenhouse gas emissions.
- **Reduced Risk to Occupants:** The smaller volume of refrigerant used in air-to-water heat pumps also reduces the risk of exposure to harmful refrigerants for occupants. This is because the refrigerant is confined within the closed loop of the refrigeration circuit in the outdoor unit, minimizing the chance of leaks that could release the refrigerant into the living space.
- **As Monoblock heat pumps come pre-charged with refrigerant, there is no refrigerant connections being made in the heat pump, there is little danger of leaks meaning a safer, more environmentally conscious choice.**

### Traditional refrigerant-based system

- R32 volume: 5 - 10 litres
- Estimated weight: 2.55 - 5.1 kg

### Monoblock Air to Water Heat Pump

- R32 volume: 2 - 5 litres
- Estimated weight: 1.02 - 2.55 kg

\*Estimate Based on typical 180m<sup>2</sup> House

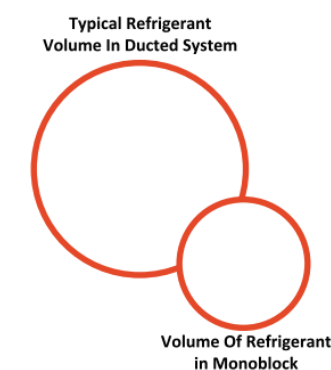

## Reduced Operating Costs

An exercise was completed to compare the capital cost, operating costs, and maintenance costs of an air to water heat pump system compared to a ducted air conditioning system. Both systems were selected to heat and cool a home floor area of 170m<sup>2</sup> built to the current H1 AS1 insulation minimum levels and located in Canterbury.

The cost of system servicing was included, and the life expectancy of the components was considered with the capital value of replacing these items spread evenly over the period rather than in a single lump sum. All annual costs were inflation adjusted at a rate of 3% annually.

The graph below shows the expected operating costs of these heating and cooling systems over a 20-year period:

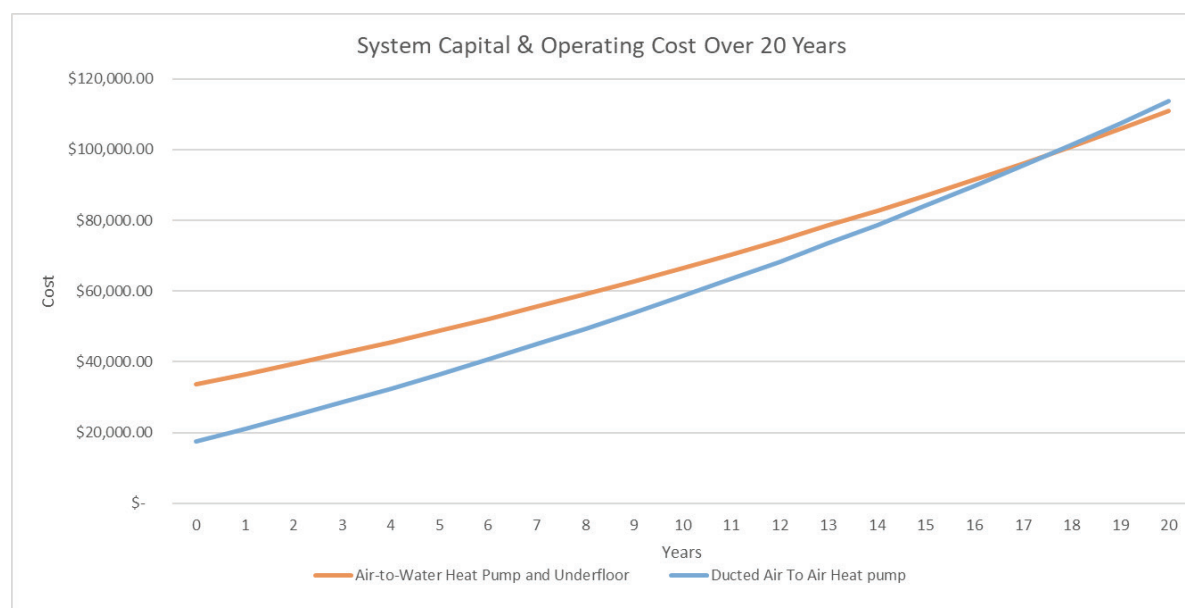

The ducted central heating system has a lower capital cost at around \$16,000 less to install than the air to water heat pump system, by the end of the 20-year period the difference in total operating costs between these two systems is around \$3,000, with the increased efficiency of the air to water system having overcome the initial difference in capital cost all while providing a more luxurious form of heating.

The assumptions used in the graph above allow for more intermittent use of the ducted system v's the underfloor system having many more run hours, in total underfloor heating system provides around 9000kWh of heating or cooling energy to the home than the ducted system ensuring a more even and stable temperature is achieved throughout the home. Even with this increase in run time and comfort the underfloor heating systems annual running cost is only around \$1,800/year v's \$1,900/year for the ducted system (based on \$0.27/kWh).

Further to the savings achieved in space heating, any cooling a hydronic underfloor heating and cooling system can also provide the homes domestic hot water heating, for a 4-person family the heating of the hot water will be around 4380kWh/year. When comparing the operating costs of heating this volume of hot water by the heat pump system v's direct electrical resistance heating, we can see a significant reduction in both the operating costs of the system and the carbon emissions attributed to these operating costs as shown in the graphs below:

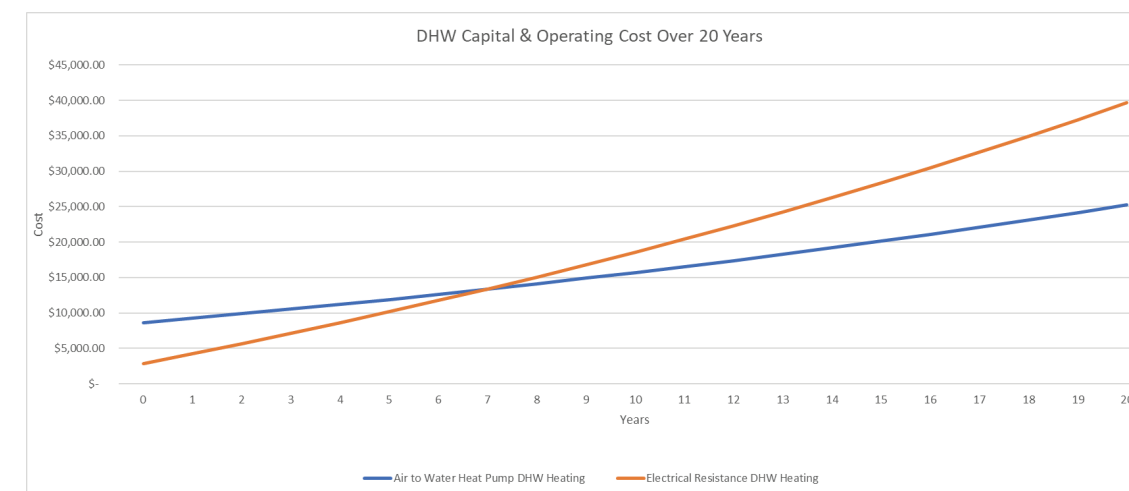

Annual operating cost savings are around \$800/year and include allowances for maintenance, component life expectancies, and inflation over a 20-year period the heat pump heating of the homes domestic hot water will save almost \$15,000.

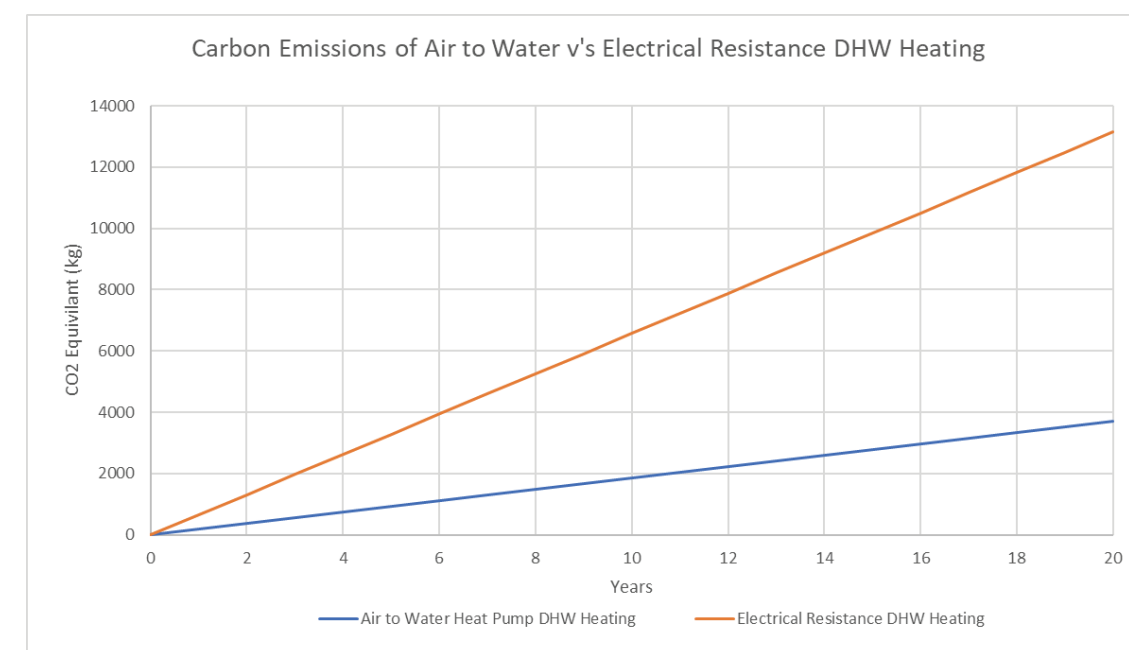

More impressive than the operating cost savings is the 9500kg reduction in carbon emissions.



## Improved Comfort

The human body works to regulate our internal temperature to ensure our internal organs are functioning optimally, the ideal internal temperature is 37°C. In most situations this means that we are the warmest thing in the room, to maintain our body at 37°C our body loses heat to the environment around us. This heat loss from our bodies is done via radiation, convection, respiration, evaporation, and conduction, the ratio of heat lost via each of these methods needs to be balanced at the perfect ratio (as shown in the graphic below), when this ratio of heat loss is achieved, we feel comfortable.

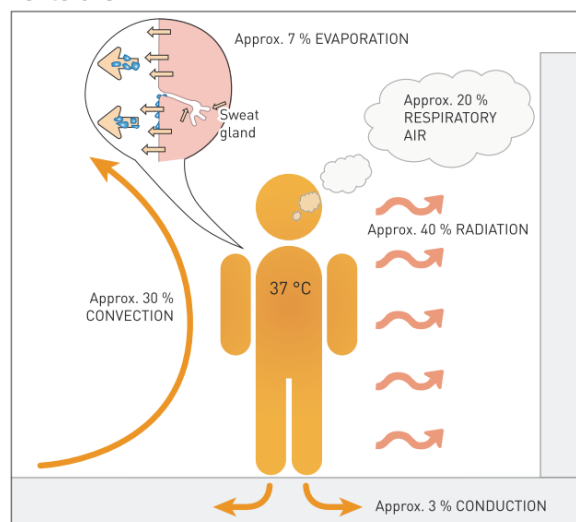

▲ Human heat balance

To ensure this heat loss balance is achieved we need to consider not only the air temperatures that are achieved in summer and winter but also the surface temperatures, if in the winter we have a warm room temperature but cold surfaces, or conversely in summer we have cool air temperatures but hot surfaces around us we do not feel comfortable or the air temperatures need to be heated or cooled to much greater levels to achieve some level of comfort. See the “zone of cosy” below for the relationship between air and surface temperatures required for comfort to be achieved:

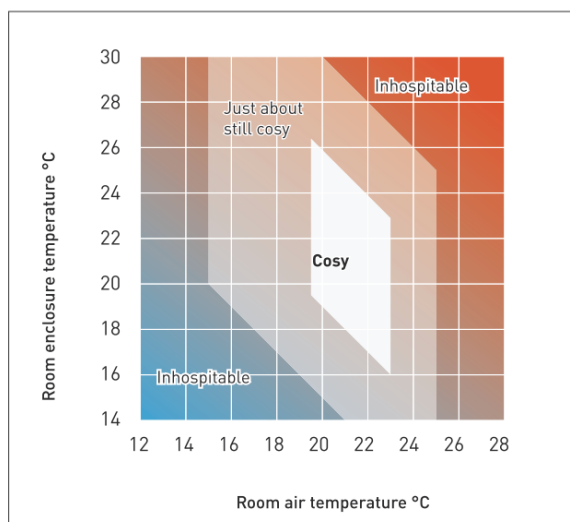

▲ Zone of cosiness

When radiant heating and cooling systems are used, we are managing both the surface temperature and air temperatures, and this allows us to achieve a higher level of internal comfort at a lower air temperature in the winter and higher air temperature in the summer.

- Air temperature control only:

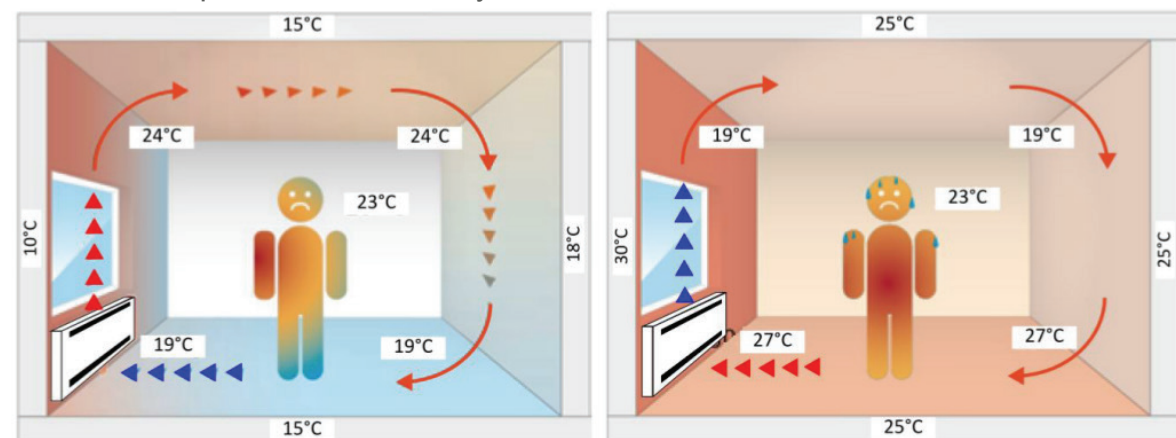

- Air and surface temperature control:

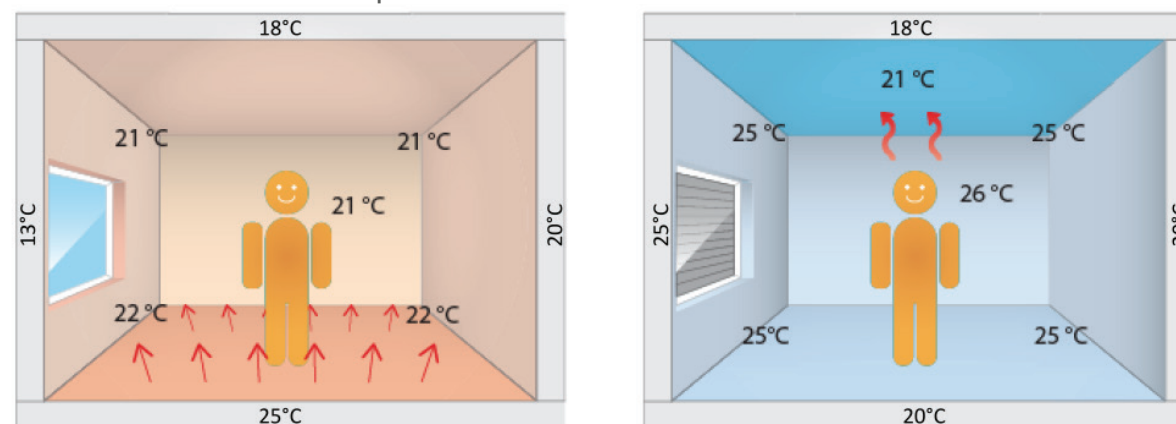

For every 1°C reduction in heating or increase in cooling set point the energy required to achieve this reduces by around 10%, this allows radiant heating and cooling systems to achieve significant operating cost savings:

- Heating – air only systems require 23°C, radiant systems only require 21°C = 20% saving
- Cooling – air only systems require 23°C, radiant systems only require 26°C = 30% saving

## Improved System Efficiency

Ducted heating and cooling systems transfer energy from the outdoor unit to the indoor unit via refrigerant pipes, but then the indoor unit uses a large fan to move heated or cooled air around the building to control the space temperatures. On contrast a water-based system uses water to transfer energy from the outdoor unit all the way to the internal heating or cooling system, by volume water can transport 3300x more energy than the same volume of air, this factor allows a water based system to transport heat around a building with much less energy required to operate the circulation pump than the fan in a ducted unit.



Dark blue = energy in unit of water  
Light blue = the energy in the same volume of air

As the heating and cooling from a water based radiant heating and cooling system uses large surfaces to transfer the energy the refrigerant does not need to be heated as high in the winter or as low in the summer as a ducted system this also helps to increase the efficiency of a water based radiant system. Water based radiant heating and cooling systems will reduce running costs by at least 20% compared to a ducted system and while costing less to run will achieve a higher level of comfort.

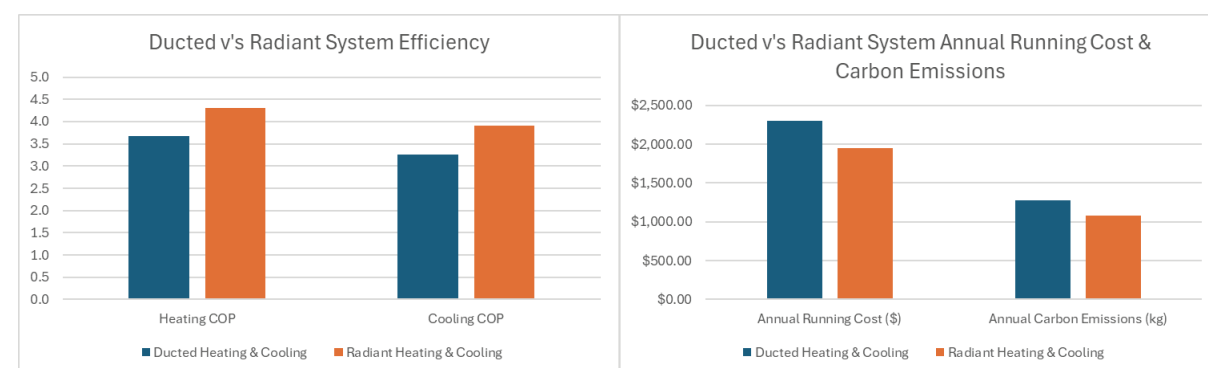

## Central Heating Compliance with H1

### Heated Floor Compliance

Hydronic underfloor heating is an efficient and comfortable way to heat indoor spaces. However, it's important to be aware of specific building compliance considerations when incorporating this heating system into a project.

As underfloor heating is considered embedded heating, it introduces different requirements that must be observed to ensure optimal performance and compliance with building standards. Below outlines key considerations for architects when planning for hydronic underfloor heating in their projects.

The country is broken up into 6 climate zones with a range of minimum heated floor R values required depending on the location of the project:

**TABLE 2.1.2.2A: Minimum construction R-values for heated ceilings, walls or floors**  
Paragraph 2.1.2.2 a), 2.1.3.1

Building element	Construction R-values (m <sup>2</sup> K/W) <sup>(1),(2),(3)</sup>					
	Climate zone 1	Climate zone 2	Climate zone 3	Climate zone 4	Climate zone 5	Climate zone 6
Heated ceiling <sup>(4)</sup>	R6.6	R6.6	R6.6	R6.6	R6.6	R6.6
Heated wall	R2.9	R2.9	R2.9	R2.9	R2.9	R2.9
Heated floor	R2.5	R2.5	R2.5	R2.8	R3.0	R3.0

**Notes:**

- (1)  $R_{in}/R$ -value < 0.1 and  $R_{in}$  is the thermal resistance between the heated plane and the inside air.
- (2) Floor coverings, for example carpet or cork, will reduce the efficiency of the heated floor.
- (3) Climate zone boundaries are shown in [Appendix C](#).
- (4) In roofs with a roof space, where the insulation is installed over a horizontal ceiling, the roof R-value may be reduced to R3.3 for a distance of up to 500 mm from the outer edge of the ceiling perimeter where space restrictions do not allow full-thickness insulation to be installed.

H1/AS1 Also includes the following statement:

*“For building elements with embedded heating systems, the minimum construction R-values shall be determined through the Schedule method. These apply whenever building elements that are part of the thermal envelope include heating systems and may not be reduced by applying the Calculation method”.*

This means that this minimum value specified in the table cannot be reduced by offsetting this with higher insulation values in other areas.

A number of proprietary floor slab insulation systems are available in New Zealand and Central Heating has compiled a table of the most common systems and their corresponding construction R values at different Area/Perimeter ratios:



Supplier	Slab/Insulation Type	Area/Perimeter							
		1.6	1.8	2	2.2	2.4	2.6	2.8	3
Alied	QuickSet Taper 305/100 with Polypod	1.9	2.06	2.22	2.33	2.45	2.57	2.69	2.81
Alied	QuickSet Ultra 305/50 with QPOD	2.03	2.17	2.3	2.4	2.5	2.6	2.69	2.79
Alied	QuickSet Ultra 305/50 with Polypod	2.15	2.3	2.44	2.56	2.67	2.79	2.91	3.02
Alied	QuickSet Ultra 305/75 with QPOD	2.2	2.35	2.49	2.59	2.7	2.8	2.9	3
Alied	QuickSet Ultra 305/75 with Polypod	2.46	2.62	2.79	2.93	3.07	3.21	3.34	3.48
Alied	QuickSet Ultra 305/100 with Polypod	2.6	2.79	2.98	3.11	3.24	3.36	3.49	3.61
Alied	QuickSet Rebate 120/305/50 with Polypod	2	2.14	2.27	2.39	2.51	2.63	2.75	2.86
Alied	QuickSet Rebate 120/305/75 with QPOD	1.98	2.13	2.28	2.38	2.49	2.59	2.69	2.8
Alied	QuickSet Rebate 120/305/75 with Polypod	2.15	2.31	2.47	2.59	2.7	2.81	2.92	3.03
Alied	QuickSet Rebate 120/305/100 with Polypod	2.3	2.47	2.65	2.79	2.93	3.07	3.21	3.25
Maxraft	MAXSlab 300	2.77	2.99	3.22	3.38	3.54	3.7	3.86	4.02
Maxraft	MAXSlab 350	2.96	3.25	3.53	3.69	3.85	4.01	4.17	4.33
Maxraft	MAXSlab 400	2.89	3.17	3.45	3.65	3.84	4.04	4.04	4.23
Maxraft	MAXSlab 300 Brick Rebate	2.27	2.48	2.68	2.83	2.99	3.14	3.29	3.44
Maxraft	MAXRaft Plus+ 320 (50/50 POD)	2.38	2.54	2.7	2.86	3.02	3.18	3.35	3.51
Maxraft	MAXRaft Plus+ 400 (50/50 POD)	2.44	2.62	2.81	2.97	3.13	3.29	3.46	3.62
Maxraft	MAXRaft Plus+ 320 (SG POD)	2.5	2.67	2.84	3.01	3.19	3.36	3.53	3.7
Maxraft	MAXRaft Plus+ 400 (SG POD)	2.54	2.74	2.94	3.11	3.28	3.45	3.63	3.8
Maxraft	MAXRaft Plus+ 320 Brick	2.18	2.38	2.59	2.71	2.83	2.95	3.07	3.19
Maxraft	MAXRaft Plus+ 400 Brick	2.11	2.29	2.47	2.6	2.73	2.86	2.99	3.12
Firth	RibRaft HotEdge Extra + 75mm XPS or 50mm EPS (H-grade) Under slab	1.87	1.98	2.08	2.17	2.26	2.36	2.45	2.54
Firth	RibRaft Xpod HotEdge Extra + 75mm XPS or 90mm SlabX200 Under slab	2.34	2.47	2.61	2.74	2.87	3	3.13	3.2
Firth	RibRaft Brick + HotEdge + 75mm Or 90mm SlabX200 Under slab	1.91	2.04	2.27	2.4	2.53	2.65	2.78	2.9
Firth	305mm Slab using RibRaft 220mm + HotEdge Extra + 50mm EPS (H-grade) under slab	2.01	2.15	2.29	2.39	2.49	2.58	2.68	2.78
Firth	305mm Slab using RibRaft 220mm + HotEdge Extra + 75mm XPS or 90mm SlabX200 under slab	2.48	2.63	2.78	2.91	3.06	3.19	3.33	3.47
Firth	305mm Slab using RibRaft 220mm Brick Veneer + HotEdge Extra + 75mm XPS or QPOD + Quickset Ultra + 20mm Edge + 50mm Under XPS	1.99	2.12	2.25	2.36	2.46	2.57	2.67	2.78
QPOD	QPOD + Quickset Ultra + 20mm Edge + 75mm Under XPS	2.18	2.33	2.47	2.57	2.68	2.78	2.88	2.98
QPOD	QPOD + Quickset Rebate + 20mm Edge + 75mm Under XPS	1.82	1.94	2.06	2.17	2.28	2.39	2.5	2.61
QPOD	QPOD + Quickset Rebate + 20mm Edge + 75mm Under XPS	1.97	2.12	2.26	2.37	2.47	2.57	2.68	2.78

This table is provided for reference only, please check with the supplier for your project requirements.

- Red = no heated floor compliance
- Yellow = heated floor compliance possible for climate zones 1-4
- Green = heated floor compliance for climate zones 5 & 6

As is clear from the table above the biggest impact on increasing the floor slab R value is increasing the Area/Perimeter ratio.

For projects where compliance cannot be achieved with the systems listed above applying a layer of insulation and floating underfloor heating system (i.e. Variocomp) above one of these listed floor systems can be used to achieve compliance and enhance the home with a radiant floor system.

## Heated Ceiling & Walls

Heating and cooling of walls or ceilings using the Variotherm Module panel system is an alternative to heating or cooling the floor and will provide a high level of radiant comfort, another benefit of this system of a floor based radiant system is that this is the final lining of the walls or ceilings and we don't have to worry about coverings being applied over this surface limiting the performance like we have to with floors.



H1 AS1 and AS2 provide specific insulation requirements for heated and cooled walls and ceilings;

- For ceilings the minimum R value required (6.6) is the same as is specified for standard ceilings but no reduction of this through the calculation method will be permitted.

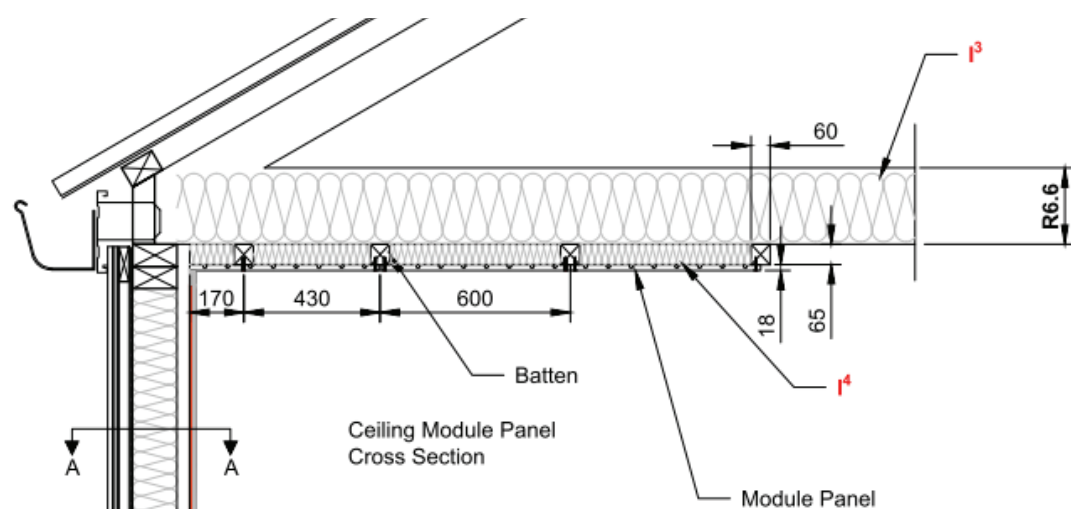

- For walls the minimum R value is 2.9, this is a 45% increase over the R2.0 that is specified otherwise, once again it is not possible for this value to be reduced through the calculation method and R2.9 must be achieved.

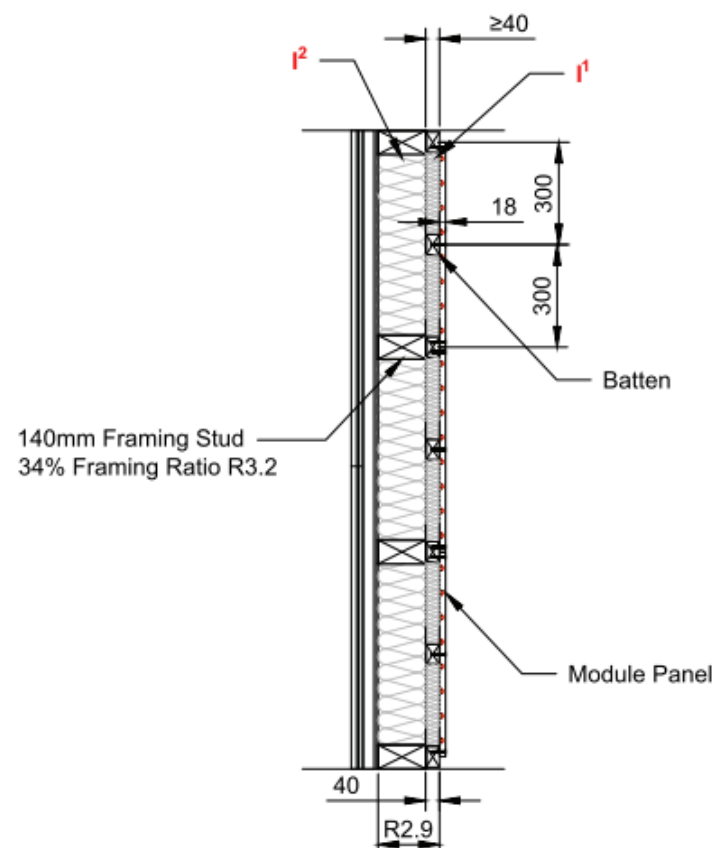

A further factor when using these systems for the heating and cooling of walls is that the batten spacing required for the fixing of the panels is 300mm, however this additional battened wall depth will allow an extra layer of insulation to be used and the R2.9 requirement to be achieved.

## Product Specification Guide

### Underfloor Installation Methods

#### Types Underfloor Pipe Installations

There are several different methods for installing underfloor heating pipework, the 4 main methods we Specify and supply are;

- Tied To reinforcing mesh.
- Clipped to Insulation.
- Variocomp Module Panel underfloor system
- Installed on a joisted floor with aluminium spreader plates.

For more information on these methods, see our underfloor installation method guide on our website.



Please Note: with all the below methods, these are a general overview. Further details and installation specifics can be discussed with the chosen underfloor heating contractor or your Central Heating New Zealand representative.



## Tying-to-mesh

The most common underfloor heating installation method in New Zealand. Here is what architects need to know:

Method: Pipes are secured directly to the structural mesh within the concrete slab or in situations where this is not possible (insufficient pipe cover above mesh), a light gauge sacrificial mesh could be used (typically installed by the builder) below the structural mesh which can then be used for fixing of the underfloor pipe.

### Architect considerations

- Specify pipe depth: Typically, will require a minimum 50mm clearance from the top of the slab to the mesh to ensure the pipe is suitably protected.
- Collaborate with engineers: Ensure the slab design, including potential insulation needs, complies with local building codes.
- Saw cuts/Control Joints: Where possible Saw cuts should be minimised, during our detailed design we will take these into consideration & will avoid/group crossings to reduce the risk of damage to the underfloor pipe. Alternative crack control methods like inducers offer additional protection.
- Strategic pipe placement: Avoid crossing pipes under walls (high risk of damage due to fixings).

### Installation Stage

- Feed pipes would typically be installed in the slab prior to the structural mesh being laid. These can be laid in either the hardfill or recessed into the slab insulation.
- Underfloor Pipe would be installed after the structural mesh has been laid (except in cases where with sacrificial mesh is used as mentioned above) but prior to concrete being poured. There should be minimal time between pipe installation and concrete pour to ensure protection from UV damage.

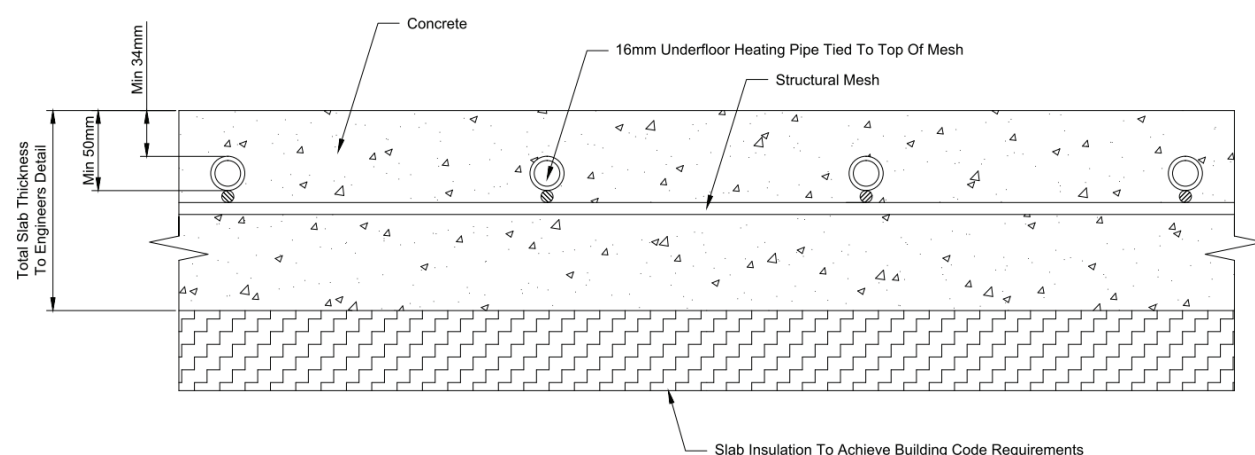

## Clipping to insulation

An alternative underfloor heating installation method when trying to mesh is not feasible

Method: Underfloor pipe is clipped directly to the high-density insulation at the bottom of either a structural slab or a thin European style screed floor. This method of underfloor install offers a fast and efficient approach for installing underfloor heating pipes in new or existing buildings. Clipping to insulation is particularly suited to projects where tying to insulation is not suitable for example a polished concrete floor where numerous saw cuts are required as this method typically provides ample clearance from the saw cuts to the pipe and is therefore at low risk of being damaged.

### Architect considerations

- Concrete cover: As the underfloor pipe will typically be deeper in the slab compared to other installation methods, consideration should be made and as a thicker layer of concrete will take longer to heat up and requires a higher water temperature to achieve desired heat output, reducing system efficiency.
- Insulation type: High-density XPS insulation is preferred for better clip fixing strength. Minimum thickness of 30-50mm is recommended for secure clipping (Insulation TBC to meet required slab R-values).
- Slab type: Not suitable for raft slabs where steel reinforcement is above the insulation layer.

### Installation Stages

- Feed pipes would typically be installed in the slab prior to the insulation. These can be laid in either the hardfill or recessed into the slab insulation.
- Underfloor Pipe would be installed after the insulation has been laid but prior to concrete being poured. There should be minimal time between pipe installation and concrete pour to ensure protection from UV damage.

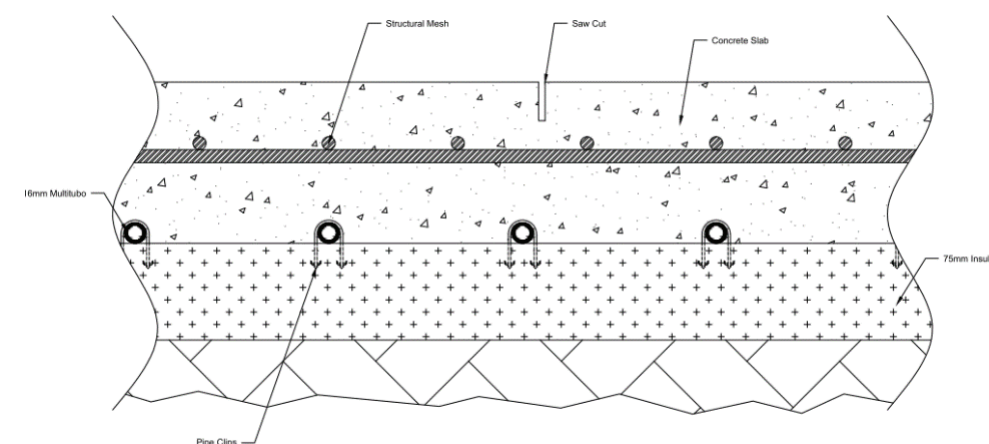

## Variocomp

### A solution for retrofit & new houses

Method: Variocomp, by Variotherm, offers a unique and efficient underfloor heating solution for both new and existing buildings. This lightweight and fast-reacting system provides several advantages for architects and builders. The Variocomp underfloor system allows retrofit installation of underfloor heating and installations in situations where more traditional methods are not feasible.

### Architect considerations

- Floor height planning: Account for the 20mm system thickness in both new builds and renovations. New builds may require design adjustments to achieve desired finished floor levels, while renovations might necessitate modifications to doors and skirting boards.
- Substrate preparation: Ensure the installation surface is clean, level, and suitable for the system.
- Floor finish compatibility: Depending on the chosen floor covering, a self-levelling compound might be required for proper installation. Allocate budget for this potential additional layer.
- System limitations: Understand the weight limitations and specific requirements for substrate insulation, especially regarding heavy objects like pianos and aquariums.

### Installation Stage

- Feed Pipe installation will vary depending on the project & where the Variocomp is being installed, for new ground floor slabs, this will be as per the above methods. For existing projects or first floor installation, feed pipe would typically be concealed within walls or sub floors.
- Construction sequencing: Plan for enclosed and weatherproofed building conditions with wall linings and window joinery installed before the Variocomp installation. Other trades should hold off work in the area until the system is complete.
- Joinery: It is common for Variocomp to be installed after kitchen/bathroom joinery has been installed however ideally it should be installed before as the floor level will be raised by 20-30mm. Blank panels without pipe can be installed to ensure a jointer is installed at the finished floor level.

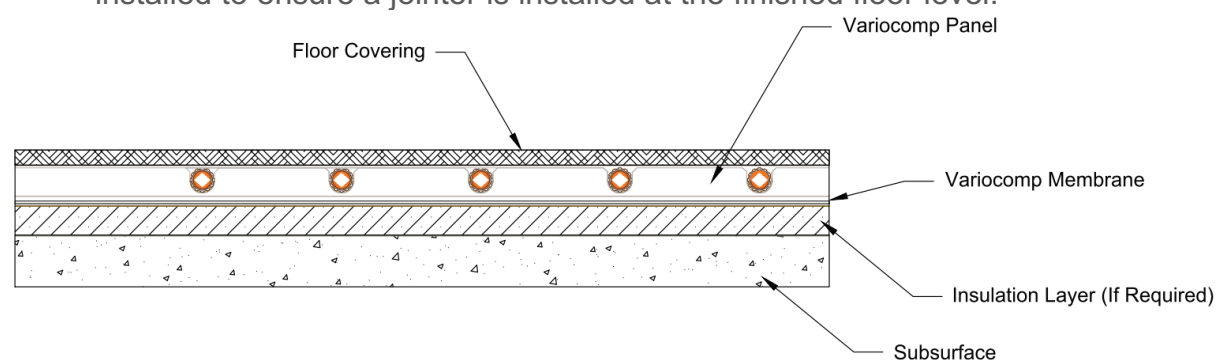

## Spreader Plates

### Underfloor Heating: Architect's Guide

Method: Spreader plates offer a straightforward underfloor heating solution for new build or renovation projects with joisted floors. This method is suitable for areas with moderate heating needs, such as upper floor bedrooms, often paired with boiler-powered systems.

### Architect considerations

- Joist spacing: Ensure a joist centre spacing of 400mm for optimal system compatibility.
- Insulation: Additional insulation (not included) is recommended beneath the spreader plates to improve heat distribution and efficiency.
- Floor construction: For upper floors, consider implementing a temporary "false floor" within the joists during installation to ensure worker safety and prevent falls.
- Heating output: While suitable for specific areas like bedrooms, this system might require supplementary heating in high-demand areas like living rooms or bathrooms.

### Installation Stage

- Spreader plates should be installed after the floor joists have been laid before the structural flooring.
- In retrofit scenarios, plates may be able to be laid from below.

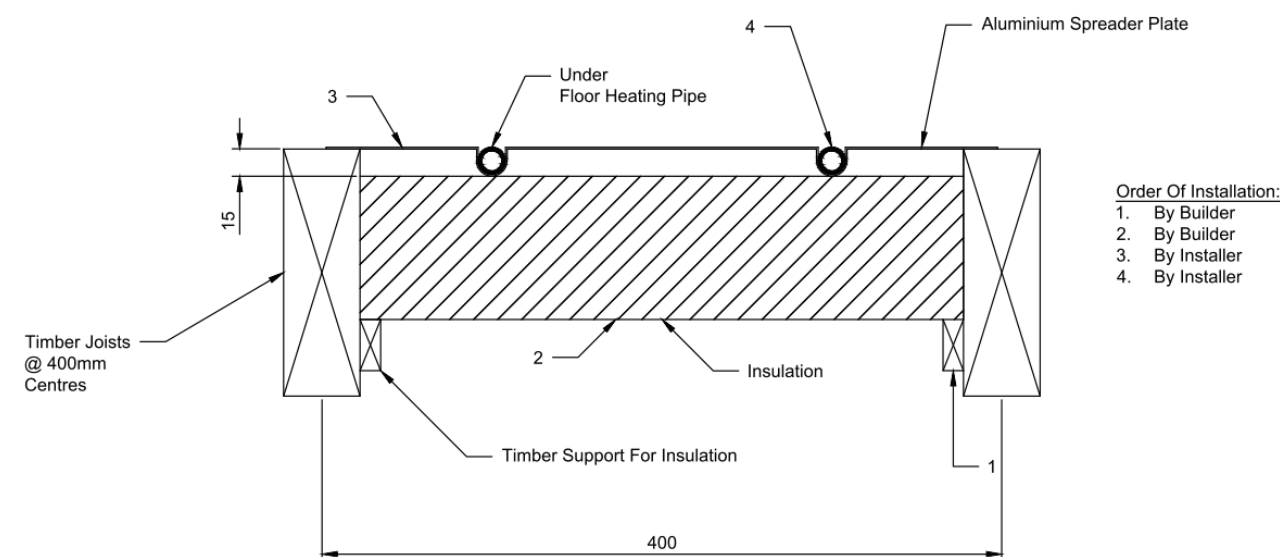



## Floor covering temperature Detail

The type of flooring you choose can significantly impact the effectiveness of your hydronic underfloor heating system. Thicker and more insulating floor coverings, like carpets, thick timber, and cork, will act as an insulator, reducing the surface temperature you feel and potentially requiring the system to run hotter to achieve the desired warmth. This can lead to inefficiencies.

On the other hand, floor coverings like polished concrete, vinyl, tiles, and thin timber allow for better heat transfer from the system to the room. This means the surface temperature will be closer to the water temperature in the pipes, and the system can operate more efficiently to heat the space.

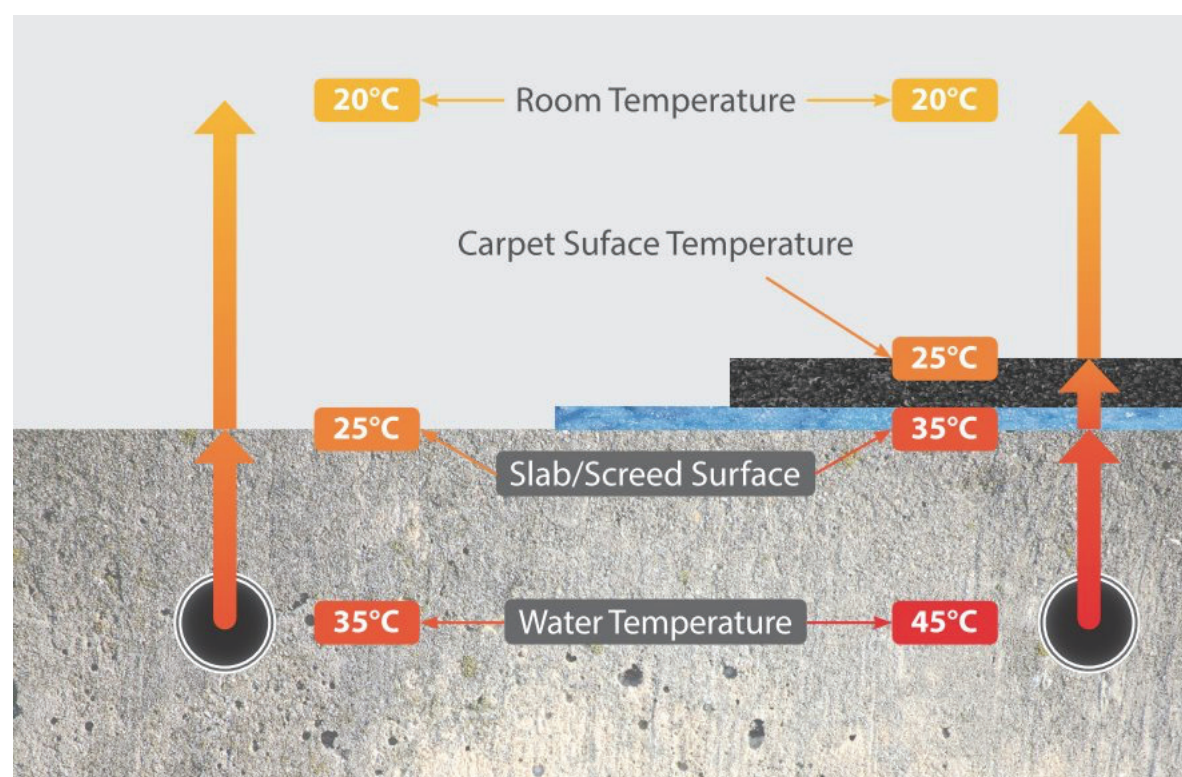

— The temperatures in this drawing are chosen to illustrate the concept being discussed and will be different in every installation.

## Underfloor Manifold Cabinet Locations

The heart of any hydronic underfloor heating system is the manifold cabinet, which controls the flow of water to the individual heating zones.

Typically, manifold cabinets are located in hallway storage or in the back of cupboards, where they can easily be accessed for maintenance and repairs. However, in many cases, these cabinets can be recessed and concealed within walls or built-in joinery, making them virtually invisible. This approach allows for a more seamless integration of the heating system into the overall design of a space and can also help to save valuable floor or storage space. For example, in a residential setting, a manifold cabinet can be recessed into a wall in a hallway, allowing it to blend seamlessly into the design of the space. In a commercial setting, a manifold cabinet can be incorporated into custom cabinetry in a break room, allowing it to serve a dual purpose as both a heating system component and storage space.

While it's the Heart of an underfloor, underfloor manifolds can be quite difficult to select an ideal location, see below some locations where it could be installed on an example project.

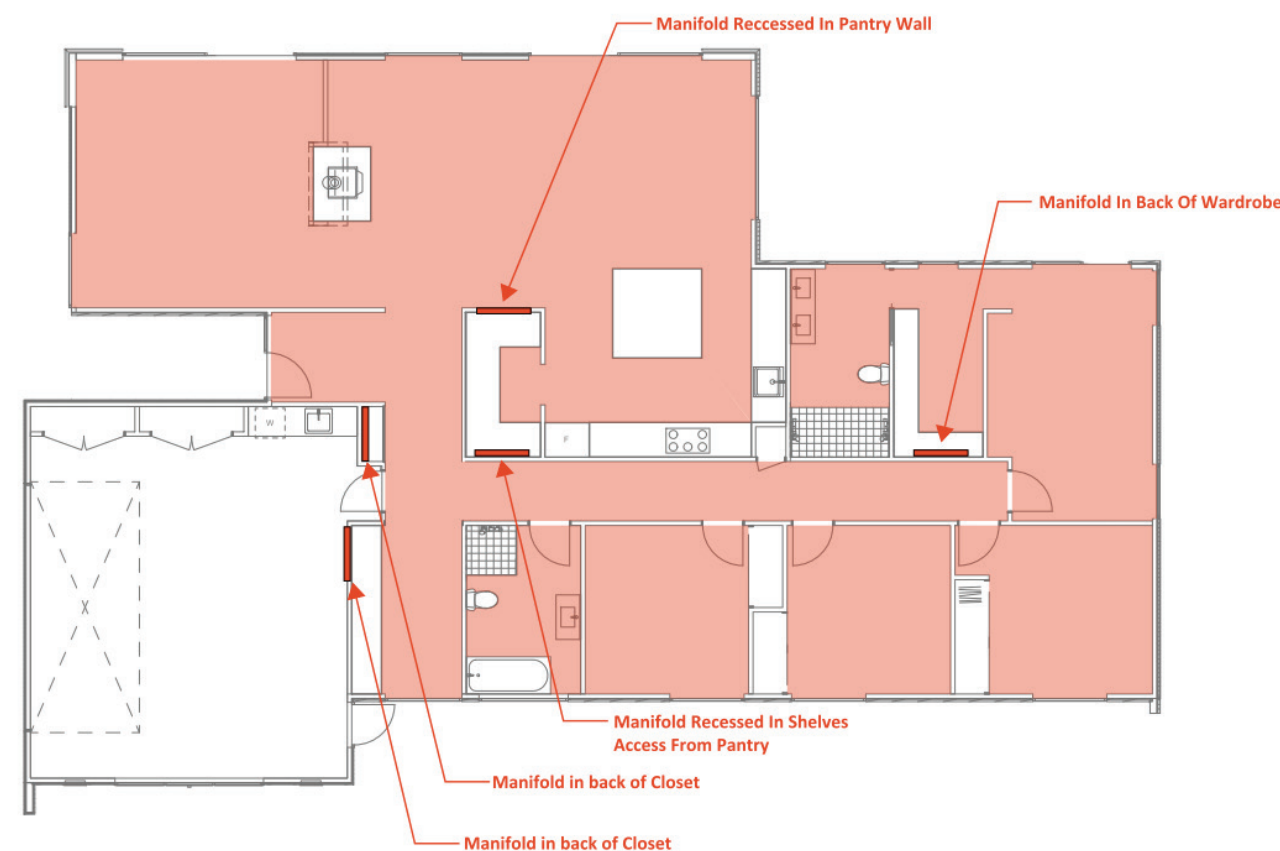

## Module Panels

The Variotherm Module Panel system can be used on both walls and ceilings to provide heating and cooling of a home. When integrating this system into a building there are some factors that need to be coordinated to allow a successful installation.

### Both System

As both systems use the same panels there are some considerations that apply whether they are being installed on a wall or ceiling.

1. **Panel Thickness:** The Variotherm Module Panel system used 18mm thick panels, where these panels do not cover the entire surface of the wall or ceiling the panels will need to transition into standard wall linings, as these linings are likely to be only 10-13mm thick a step is needed to make this transition seamless. The suggested solution for creating this transition is to frame out the 2 areas separately and to use battens of differing depths to make up the difference in panel thickness.

- Module Panel Joint Detail:

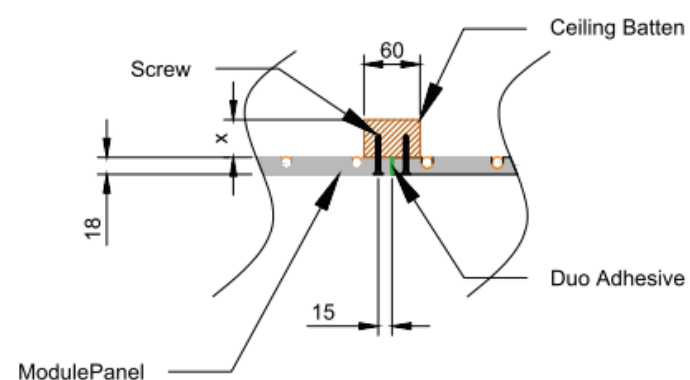

- Module Panel to GIB Joint Detail:

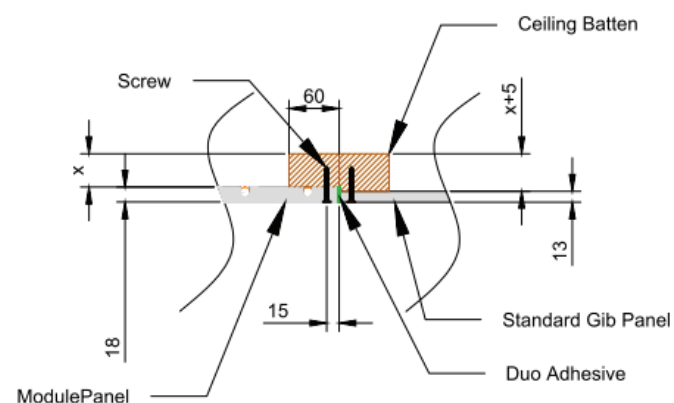

2. **Panel Finish:** The Variotherm Module Panels are a Fermacell Gypsum Fibreboard panel, unlike Gib panels these panels are not lined with an outer paper casing, this means that the surface of these panels does not have the smooth finish that Gib panels have. Additionally, as pipes are laid up to 40mm from the edge of the panels the sides are not tapered like a GIB panel. For these two reasons Central Heating New Zealand recommends that these systems are finished with a complete skim coat of plaster (L5) to achieve an even finish that would be typically expected in New Zealand.

3. **Batten Thickness:** For the Variotherm module panels screws need to be 15mm from the edge of the panel, this means that the fixing centres are 30mm and the standard Rondo battens with a 40mm fixing face is not suitable. For both wall and ceiling panel installations battens with a fixing face width of at least 60mm is recommended.
4. **Batten spacing:** The Variotherm Module panels come in a range of sizes to suit all types of installation scenarios, when planning a Module Panel installation, the best solution is for the battens to run parallel to the panels as this makes the installation and fixing of these panels easiest. The batten spacing for this option is 600mm or 625mm depending on the panel width that is available, an example of this for a ceiling installation is shown below:

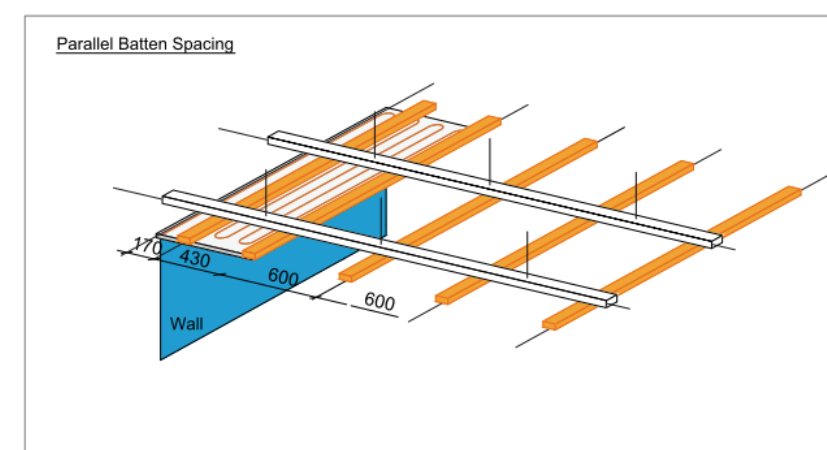

If the battens need to be run perpendicular to the panels the spacing of these needs to typically be 400mm for ModuleWall and 500mm for ModuleCeiling but this will vary depending on the panel sizes required for the installation, and example of this for a ceiling installation is shown below:

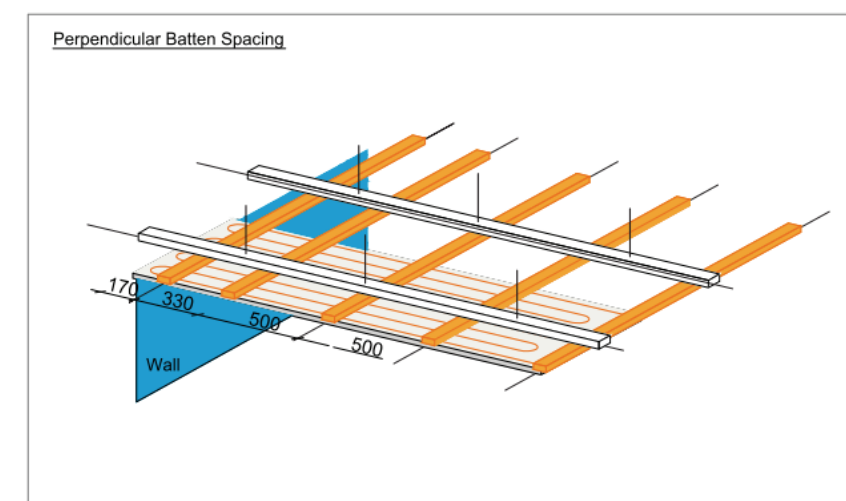



- Sensors: For both wall and ceiling systems where cooling is planned to provide the control system will modulate the flow temperature in order to prevent the formation of condensation. In the event that there is a rapid change in the indoor humidity levels the system may not be able to respond to this variance quick enough and there is a risk that condensation would begin to form. To prevent this each zone of wall or ceiling panels will have a dew point sensor taped to the flow pipe to the panels in that zone:

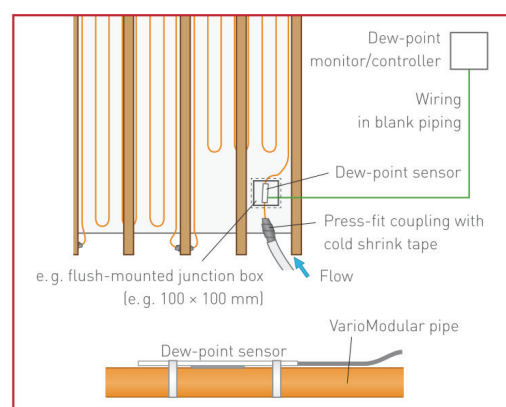

▲ Example Dew-point monitor (cooling)

The NTC sensor used has a very long-life expectancy but in the event, it does fail the ability to replace this sensor needs to be allowed for during the installation. Two possible solutions are available for this;

- At each sensor location install 3 separate sensors to provide redundancy.
  - The preferred option is for the sensor to be located behind a blank wall outlet or ceiling access panel to allow for the future replacement of this sensor should this be needed.
- Locating Pipes: For the future fixing or cutting of installed panels it is important that the pipes are located first.

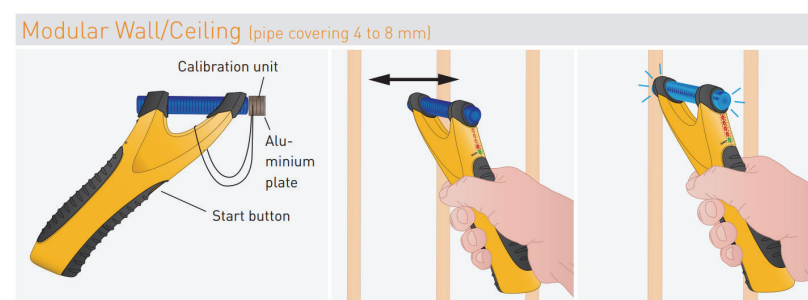

## ModuleCeiling

The additional planning step required for the ModuleCeiling system is the for the integration of lighting or ceiling vents. To allow for the integration of these elements within the system once of the following options can be used;

- Variable panels: the variable panels have a 300-800 long space within the panel where pipe is not fitted apart from on each edge of the panel, these panels can then be installed to allow a lighting or ventilation elements to be cut into this during or after the panel installation.
- An entire panel in the active ceiling can be removed and replaced with a blank panel, these panels can be 1000m to 2000mm long and match the width of the other panels used in the system (600mm or 625mm).
- Lighting could be planned to be surface mounted on the panels with this lining up with a supporting member behind the panel but avoiding pipes.
- To maximise the performance of the system lighting and ventilation elements could be kept outside of the active panel area.

## ModuleWall

The additional planning step required for the ModuleWall system is the for the integration of light switches and power outlets. To allow for the integration of these elements within the system once of the following options can be used;

- Variable panels: the variable panels have a 300-800 long space within the panel where pipe is not fitted apart from on each edge of the panel, these panels can then be installed to allow horizontal power outlet, wall mounted light, or similar to be cut into the panel.
- It is permissible to create a 50mm wide vertical opening in the panels, this must be measured out to be perfectly central between pipes and it is recommended that this is measured out and cut out prior to fixing the panels. This 50mm wide opening can be used to allow the installation of vertical switches or power outlets.
- An entire panel in the active wall can be removed and replaced with a blank panel, these panels can be 1000m to 2000mm long and match the width of the other panels used in the system (600mm or 625mm).
- Surface mounted switched or lighting could be planned to be used on the panels with this lining up with a supporting member behind the panel but avoiding pipes.
- To maximise the performance of the system switches and power outlets could be planned to be kept outside of the active panel area.

# Radiators

## Radiator Positioning in a Building

Radiators need to be positioned throughout a building to provide an even spread of heat. This typically means at least one radiator per room. Larger rooms or unusual shaped rooms will require more than one radiator. The technically correct position for radiators is on an external wall or under a window.

This is because the coldest part of the room is the best place to combat the cold. In rooms that have large windows, the cold air drops off them and a radiator positioned below can counteract this downdraft.

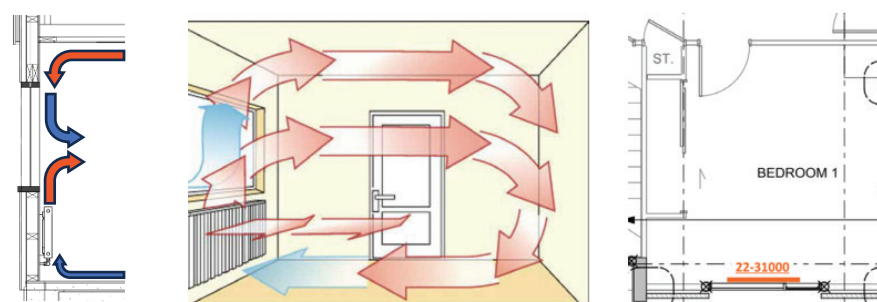

## Radiator Height from the Floor

Typically, standard radiators are mounted so that the bottom of the radiator is 180mm from the floor. The governing factor from an aesthetic point is the height of the skirting boards that will be present. If the skirting boards are tall the radiator can be mounted higher than 180mm to ensure the pipework does not penetrate through the skirting. If the radiator is going under a window, we would typically recommend at least 100mm clearance from the windowsill to the top of the radiator to ensure the curtains can hang however if required the radiator could be flush with the sill.

## Recessing Radiators into Walls and Joinery

In a new or renovation project, radiators can be recessed into the walls or joinery units to lessen obtrusiveness. The space required around the radiator so that there is no impedance on heat output due to insufficient natural air movement, is a minimum of 10% of the height of the radiator. On installations where there is a thermostatic valve is aesthetically better to have at least 150mm around the radiator.



## Typical Radiator Pipe Work Detail in Wall Framing

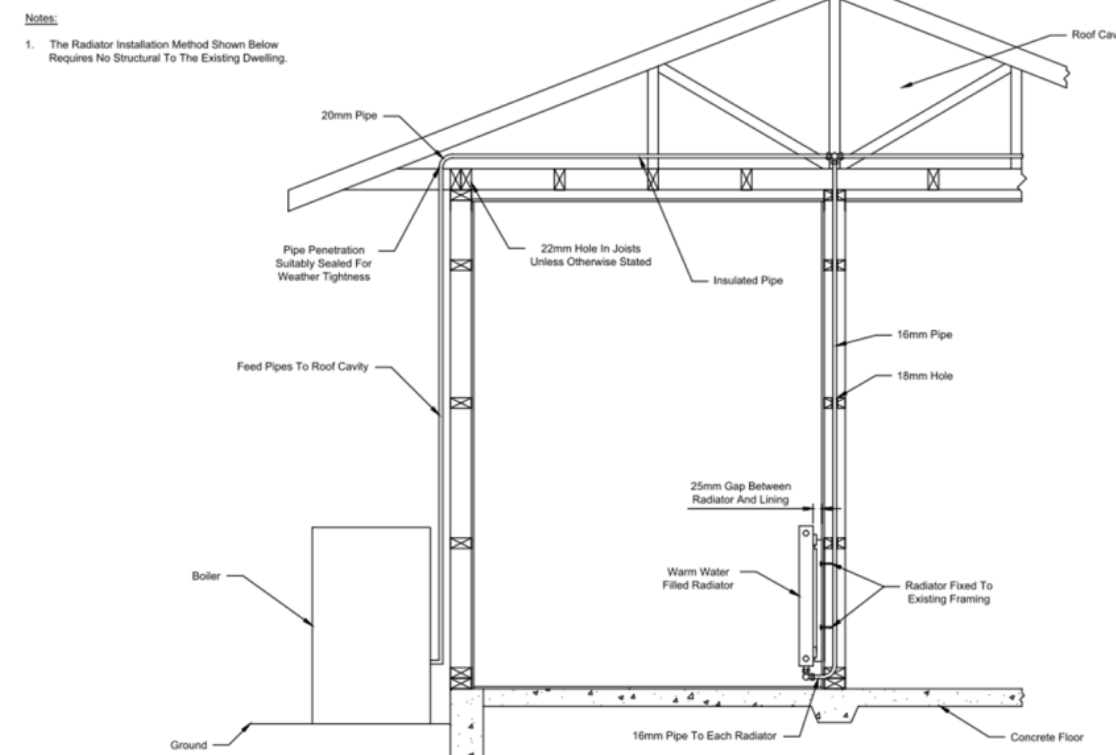

## Typical Radiator Pipework Detail in Joisted Floor

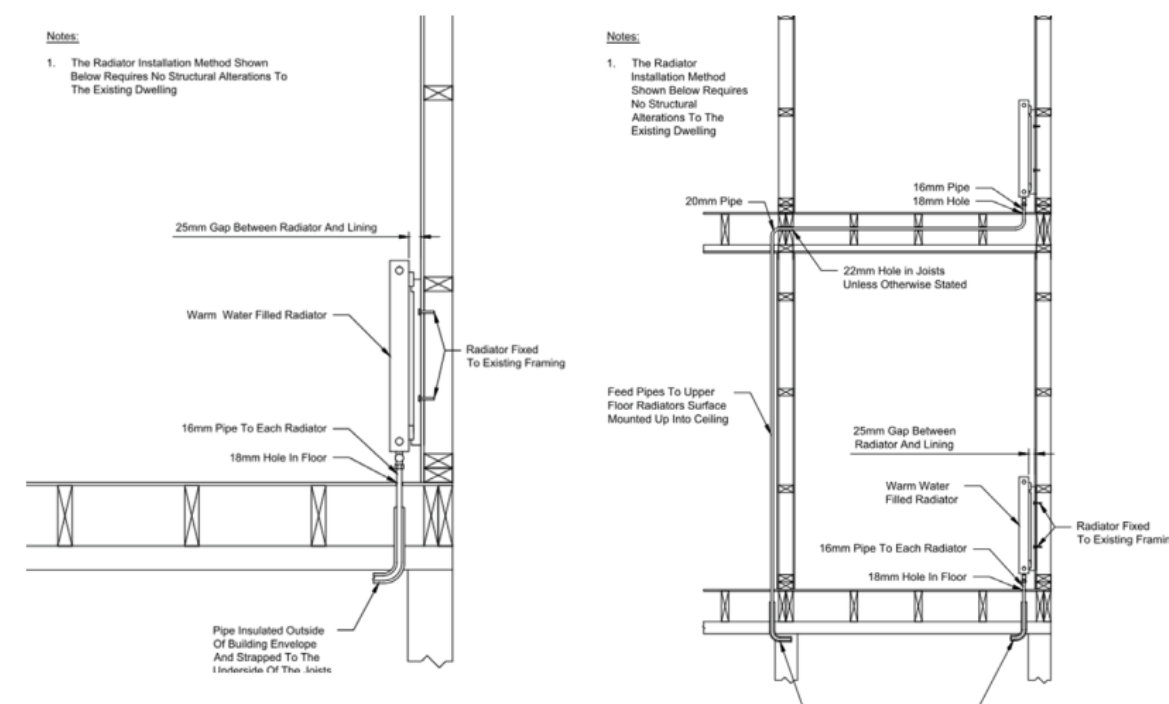

## Hot Water Cylinders

### Product Range

When domestic hot water heating is added to a central heating system a special cylinder with an internal heating coil is required, this coil allows for the heating systems water to be pumped through the inside of the coil and to then heat the domestic hot water inside the tank. It is especially important for heat pump systems that this coil is selected to match the requirements of the heat source, Central Heating New Zealand will always specify the correct cylinder type for each system.



300L Single Coil



300L Twin Coil

The following components are supplied with each cylinder:

- Baxi Single Coil:
  - 3kW electric element – supplied loose.
  - 850kPa TPR and installation fittings – supplied loose.
  - Indirect thermostat – supplied factory fitted, remove if cylinder is used in a heat pump system.
- Megaflo Twin Coil:
  - 3kW electric element – supplied factory fitted to upper tank port, related to the lower port for a heat pump system.
  - 850kPa TPR – factory fitted.
  - Indirect thermostat – supplied factory fitted, remove if cylinder is used in a heat pump system.

The cylinders used for these systems are a stainless-steel tank manufactured in the UK and are available in the following sizes:

- Baxi Single Coil:
  - 200 litre (Ø550mm x 1500mm high)
  - 300 litre (Ø550mm x 2066mm high)

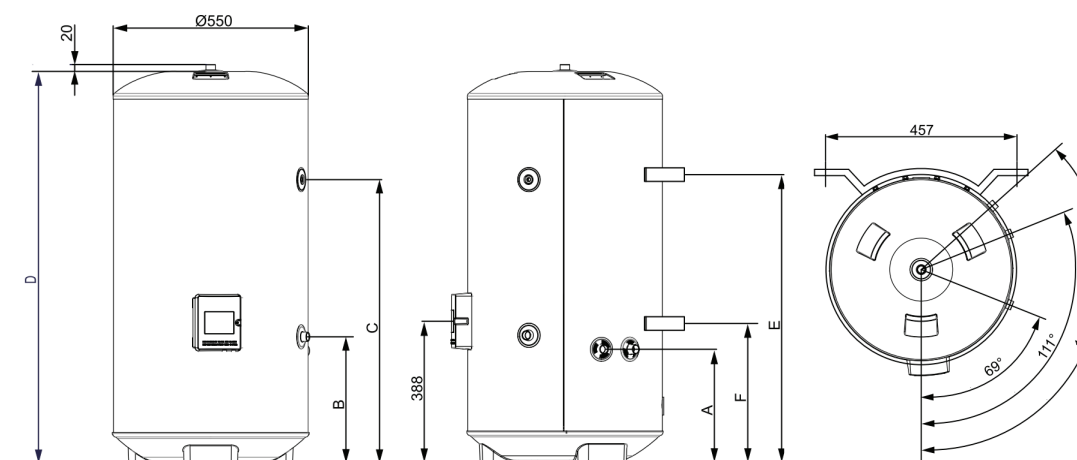

CAPACITY	DIMENSIONS (mm)						WEIGHT (kg)	
	A	B	C	D	E	F	EMPTY	FULL
200	314	354	1096	1480	1092	387	38	249
300	314	354	1480	2046	N/A	N/A	60	360

- Megaflo Twin Coil:
  - 300 litre (Ø600mm x 2073mm high)

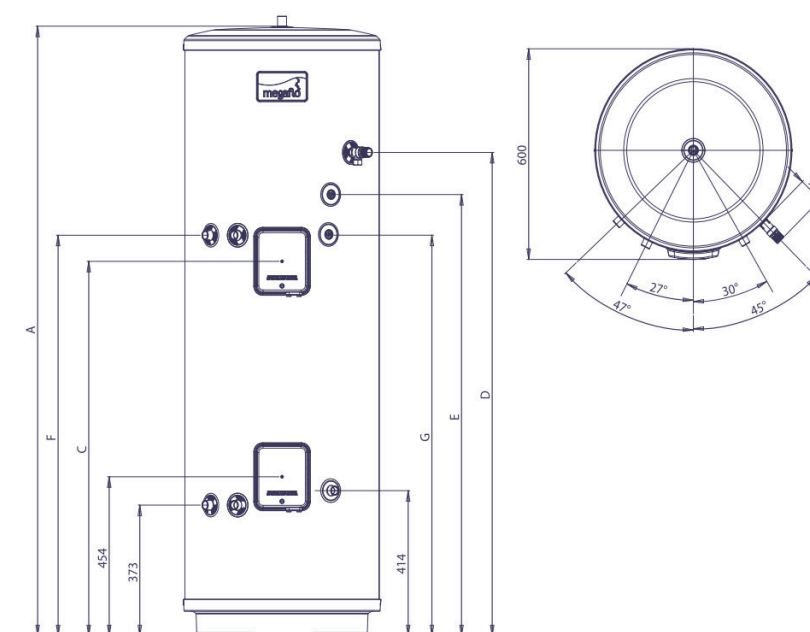

Size	DIMENSIONS (mm)						
	A	B	C	D	E	F	G
300si	2053	N/A	1255	1693	1573	1438	1473



## Installation Clearance

To ensure the installation of these tanks can be easily connected into the central heating system and homes plumbing system the recommend installation space for each model is shown below:



Tank Model	H	W	D
200 litre single coil	1800mm	750mm	650mm
300 litre single coil	2300mm	750mm	650mm
300 litre twin coil	2100mm	750mm	650mm

## Installation Considerations

The central heating installer may not also be the plumber for the home, the plumber and site electrician would be responsible for the following aspects of the HWC installation:

- Plumber to install the cylinder and complete the domestic plumbing, including supply and installation of a safe tray.
- The TPR will be supplied with the cylinder and the plumber will be required to fit and connect this into the drain.
- The electrical element will be supplied with the cylinder, the electrician may need to move this from the upper port in a twin coil cylinder to the lower port and then connect this to the power supply and if a heat pump system is used the timer.
- The plumber needs to ensure the installation is completed in accordance with G12:AS1.

## DHW Heating for Larger Homes

The typical solution for ensuring sufficient hot water is available in larger homes is to install multiple hot water heaters. This ensures both large volumes and short draw off times are achieved, and in most cases, this is an over specified solution due to no real guidance on what is required to meet the hot water requirements for the home.

When a central heating solution is chosen, it offers the added benefit of heating the home's hot water as well, resulting in a more effective and efficient hot water production for the entire household. In most situations, this typically requires a single location to store the hot water. In larger homes, careful consideration is essential when sizing the storage cylinder and designing the distribution system to ensure efficient and effective hot water supply.

For Central Heating New Zealand, the process to determine the requirements of the domestic hot water system is to calculate the water requirements of a peak demand period. This process involves reviewing the total outlets installed in the home, the expected occupancy, and modeling of the usage in this peak demand scenario. The model then allows us to review the storage and energy requirements to ensure that the hot water over this peak period can be supplied to the home.

### Standard Hot Water Solutions

For larger homes it would be common to use multiple hot water heaters, this provides the benefit of a short draw-off time before hot water is available at each outlet and large volumes of hot water to be provided. Boiler-powered central heating systems have the advantage of easily heating two separate hot water cylinders. Since the boiler usually has sufficient heating capacity so that reheating these cylinders doesn't typically affect the temperatures in the home.

When using a heat pump powered central heating system with a single heat pump, it is generally more efficient to heat only one hot water cylinder. While there are methods to enable a single heat pump to heat multiple cylinders, doing so can lead to a noticeable impact on the home's heating while the heat pump is reheating the cylinders. However, in systems that have multiple heat pumps, the locations of these can be strategically positioned to allow each heat pump to heat one hot water cylinder allowing high amounts of hot water to be produced with minimal impact on the homes heating system.

When a single hot water cylinder is used as part of a central heating system the distance from this to the outlets needs to be considered, where the distance from the cylinder will result in long draw off times for hot water to be available a ring main type plumbing system could be a good solution to improve the responsiveness of the hot water system.

## Ring Main Hot Water Solutions

Ring main plumbing systems are common in commercial buildings but are not as common in residential applications. These systems require an additional small pipe to be run along the hot water flow pipe and these are connected together at the last outlet. A small circulation pump is then used to induce a small flow rate around the hot water pipe allowing hot water to be available to be drawn off instantly when any hot tap is opened. The schematic below is an example of how these systems can be configured:

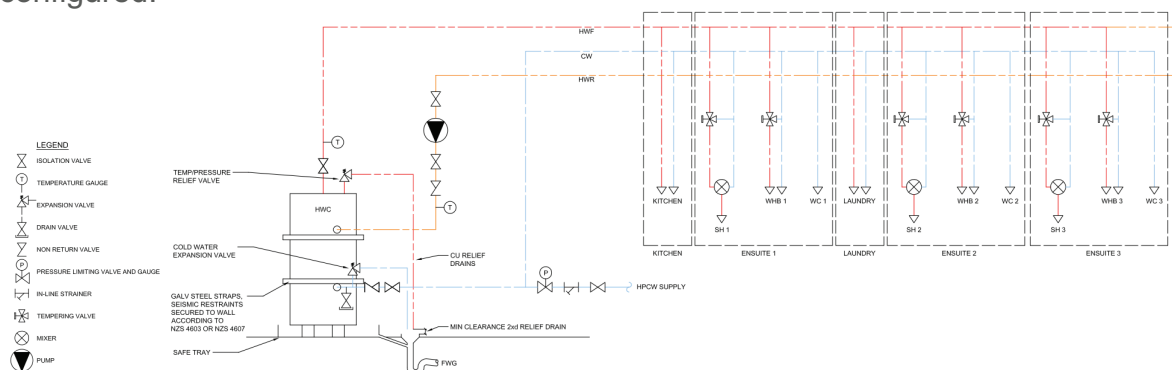

If a ring main system is used there are a number of considerations that need to be made to ensure these systems are effective and safe;

1. There are two main system types;
  - a. Tank Temperature Systems: As per the schematic above, these systems circulate tank temperature water throughout the ring main and use tempering valves to reduce the water temperature at any outlets where this is required. These systems require water storage of 60°C and the return temperature to be not less than 55°C (AS/NZS3500.4) or 60°C (G12/AS1). This layout is shown in the above schematic.
  - b. Temperature Controlled Systems: These systems use a tempering valve at the tank, and this ensures that the water to each outlet is then at a safe temperature with no need to further temper the hot water before the outlets. In this system, there is a concern that the temperature in the ring main may not meet the safety standards of being at least 55°C (as per AS/NZS3500.4) or 60°C (according to G12/AS1). To ensure a safe water supply, alternative methods are necessary. The most common method is to use a UV sterilizer and to pipe the system as shown in the below schematic.

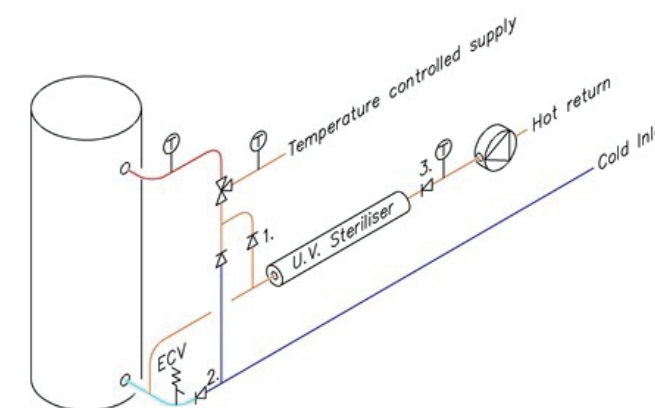

2. Ring main tempering valves: The tempering valves used in a ring main plumbing system must be suitable for that application. Most manufacturers of tempering valves make specific valves for ring main plumbing systems often consisting of check valves on both the hot and cold inlets.
3. Ring main circulation pumps: The ring main circulation pump only needs to achieve a small flow rate around the ring main, ensuring that hot water is available at each of the tempering valves. For most domestic homes this is achieved easily with a small circulation pump. Central Heating New Zealand recommend and supply the Grundfos UP15 comfort PM pumps with an integral pipe sensor and auto adapt function. Standard fixed speed pumps of an equivalent pump capacity are suitable also but should be wired through a time clock to allow the pump to be timed in peak use periods only.
4. Pipe insulation: As the hot pipe and ring main return are kept warm for long periods it is important to ensure both pipes are adequately insulated to reduce the heat loss of these pipes.

When the domestic hot water system is properly planned, designed, and installed, and is heated by the central heating heat source, the hot water supply can be nearly limitless. These systems have ample power to reheat the water efficiently, allowing for large volumes of hot water without any noticeable temperature drop at the outlets. To make the most of these benefits, it's essential to consult with a knowledgeable plumber and central heating expert who can help determine the best hot water solution for your specific home needs.



## Heat Pump Clearance Requirements

Heat pumps, like any machinery, require proper clearance around them to function efficiently and reliably. Here's a breakdown of the key points to consider:

### Why Clearances Matter

- **Airflow:** Adequate space allows for unrestricted air intake and exhaust, crucial for efficient heat transfer and preventing excessive defrosting.
- **Servicing:** Clearances enable technicians to access the unit for maintenance and repairs without difficulty.
- **Noise:** Maintaining proper distances from walls, fences, and other objects minimizes the reverberation of noise.

### Minimal Clearance Guidelines

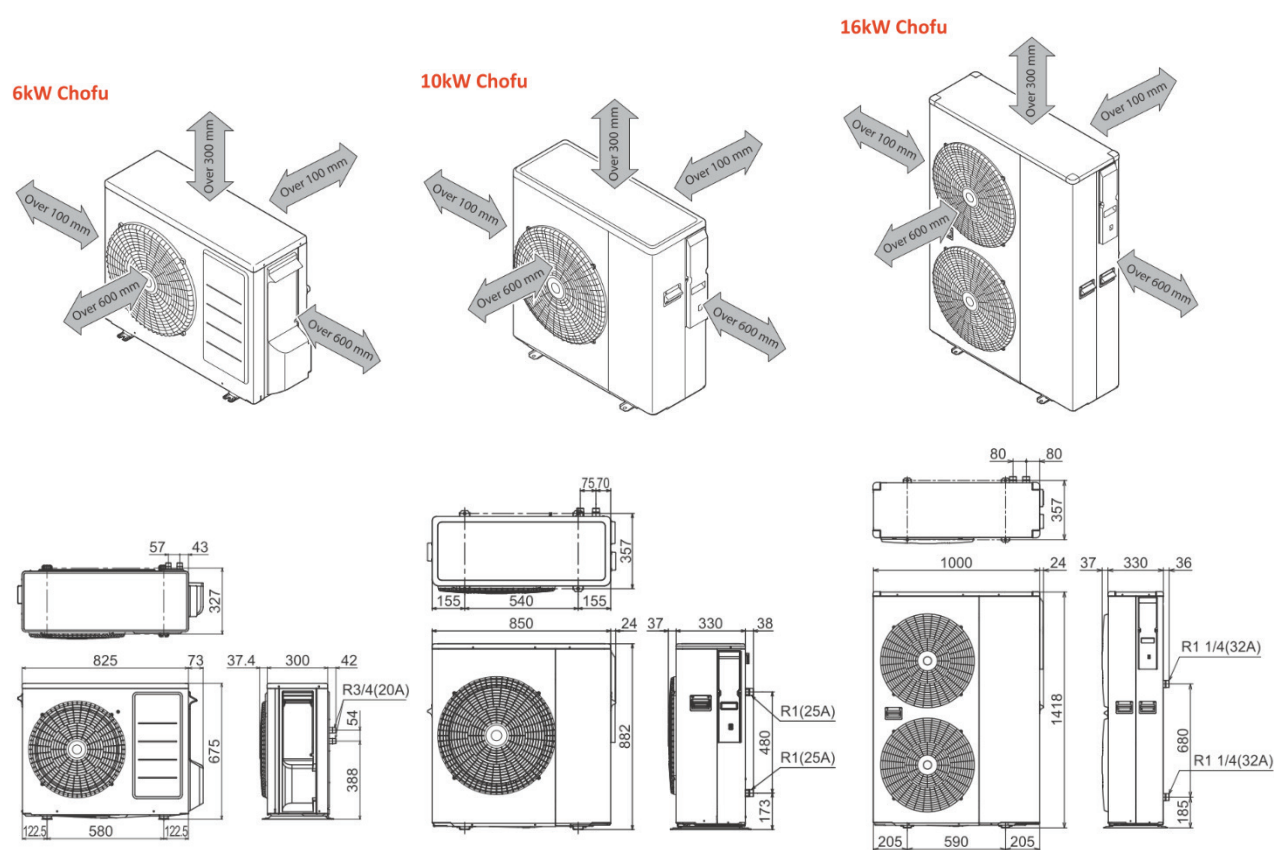

Note that for installation of the above units the recommended space behind the units is 250mm

## Covers or Enclosures

Heat pump covers or screens are generally not recommended as these will reduce the air flow around the unit causing potential reductions in performance and efficiency.

If a cover is required, an free area of greater than 90% or will be required on all sides to ensure correct operation of the heat pump, to do this and still achieve some level of screening slats can be put on an angle to and configured to prioritise screening of the unit from a certain view point. An example of an acceptable screen is shown below:

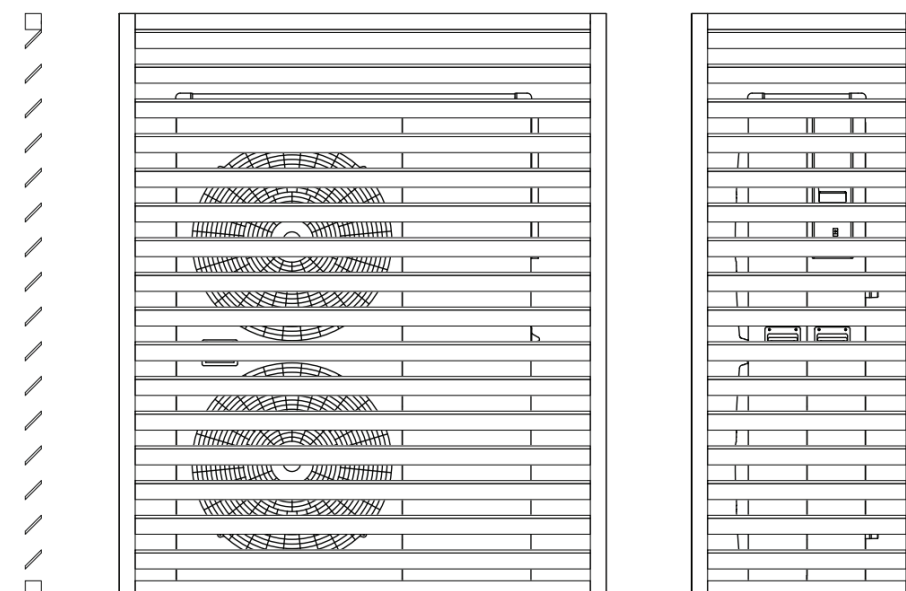

Any cover put over the heat pump needs to ensure it meets either the heat pumps minimum clearance requirements or the cover should be able to be removed to ensure suitable access for servicing.

### What not to do





## Thermostat Placement

The location of the thermostat or thermostats in a home can have a big impact on how well the system will work. There are three critical considerations when locating a thermostat.

- Internal Walls Only - Thermostats must not be installed on external walls; the conduction through the wall alters the thermostat's temperature reading, resulting in unpredictable operation.
- Avoid Direct Sunlight – Thermostats should be installed in internal walls of the home that will receive no or minimal sunlight directly on the thermostat. Sun allowed to shine on the thermostat will result in the temperature reading increasing, potentially causing the heating to turn off before the room is sufficiently warmed.
- Away from heat sources – the thermostat should not be installed directly next to a radiator or over the “hot track” of an underfloor heating system. If installed in these locations, the thermostat could turn off early as the local temperature will be higher than the remaining areas of the home or control zone.

All these factors for thermostat placement will be considered by our engineering team when design the heating system. If you need to move the thermostat locations from the designed location, ensure you consider all these factors carefully.

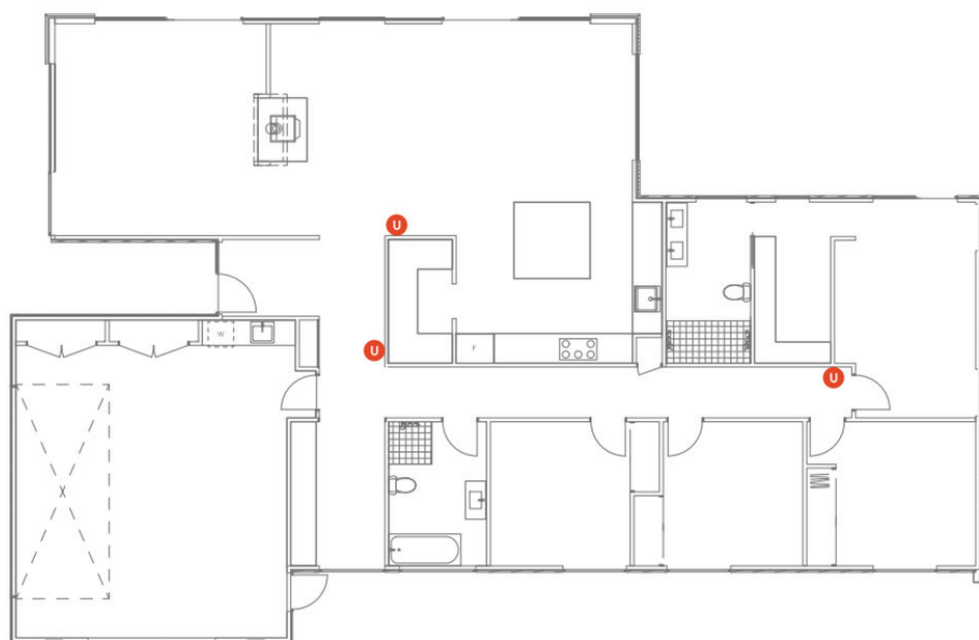

## Controls Guidelines

From the experience of designing and supplying over 13 000 central heating systems throughout New Zealand, Central Heating New Zealand has experimented with numerous controller types and methods. From this experience, we now have a good understanding of the control solutions that suit most Kiwis to ensure they have the right level of comfort in their home without excessive costs or complexity.

The best control system for any given project should consider the following factors:

1. The type of heating system installed and how it will be balanced – Both radiator and underfloor systems can be accurately balanced to ensure the right amount of heat is delivered to each area of the home. With regulating valves installed in the radiator itself or at the manifold for an underfloor heating system, the installer can set the ideal valve settings to achieve the correct amount of flow in each area. Our engineering team will provide the installer with these settings during the detailed design. Setting these regulating valves matches the heat output rate to the heat loss rate in each area, allowing all areas of the home to warm up evenly, preventing overheating or underheating in specific areas. When this balancing is done correctly, the thermostat installed in any area of the home should result in all areas meeting the desired temperatures.
2. How the home will respond to solar gain – The size, shape, and amount of glazing for a home will determine how the home responds to solar gain. Rooms with a large amount of north-facing glazing might need heating in the morning and afternoon but stay relatively warm in the middle of the day with heat from the sun alone. As a comparison, rooms with predominantly south, east, or west-facing glazing are likely to have shorter total sun hours in the winter, and these rooms will need more consistent heating throughout the day to remain warm. For some homes, these differences in sun hours between different parts of the home will result in very different heating needs. When reviewing the plans for a home, our engineering team will consider these factors, and where required, additional control zones will be added to the system to help manage these varied heating needs.
3. KISS (Keep it simple) – One of the biggest learnings over the last 20+ years for Central Heating New Zealand has been that simple systems achieve the best results. The goal should be to reduce the number of controllers as much as possible while still achieving the required heat balance for the home. Central heating systems are not a system where the user needs to be constantly adjusting the system to feel warm. Over the course of the first heating season, the set points and time schedule for heating will be adjusted to suit the needs of the occupants, and for every heating season thereafter, the heating would just be turned on at the start of the heating season and off at the end of the season with no or minimal interaction with the controller in between. The best control solution for most homes is a single thermostat; for some larger or more complex homes, a controller per zone of the home may

be needed, but thermostats for each room are not recommended or required when the balancing mentioned in point 1 is done correctly.

4. How the home will be used – The last factor to be considered is how the home will be used. It is important that the control solution suits the lifestyle of the occupants and ensures the system is easy to use, achieves the comfort levels required, and is energy efficient. The following factors need to be considered:
  - a. The hours the home is occupied - Central heating systems are generally not recommended to be turned on and off throughout the heating season. To allow some reduced comfort and energy savings outside the main comfort times, a programmable thermostat can be used to allow lower temperatures to be set during these periods.
  - b. How much of the home is used – If only parts of the home are regularly used and some areas need to be turned off, we need to consider what the best method for this control requirement is. If this is just a few rooms of a home, the most cost-efficient solution is to just close the radiator or underfloor valves to stop the flow to these areas when not in use. If large areas of the home need to be shut down when not in use, additional thermostats may need to be added to make turning these areas on and off easy.
  - c. Holiday Homes – Homes that are used occasionally typically need to be able to be remotely turned on to allow the home to be warmed up prior to arrival. When this is a requirement, we need to ensure the control solutions have remote access via mobile applications or similar.

When we don't have any direct contact with the clients for a new opportunity, it can be difficult to know all of these factors, but our engineering team tries to imagine how they would use the home and tailor the control solution to consider the above carefully.

When all these 4 factors are considered in the design and installation of a central heating system, the comfort levels and energy efficiency can be improved significantly, resulting in high levels of occupant satisfaction. Central Heating New Zealand takes care to consider all these factors when designing systems and is happy to provide advice to any clients on the best ways to control their central heating systems.





## Working with us

- Support from start to finish
- Bespoke heating and cooling designs from in-house Engineers
- Specifier material and support
- Expert knowledge with more than 13,000 central heating installations New Zealand wide
- Invisible, silent, healthy and efficient solutions



[centralheating.co.nz](http://centralheating.co.nz)

[info@centralheating.co.nz](mailto:info@centralheating.co.nz) | 0800 357 1233