

F150 Saddle Bracket - 50mm

Part No.

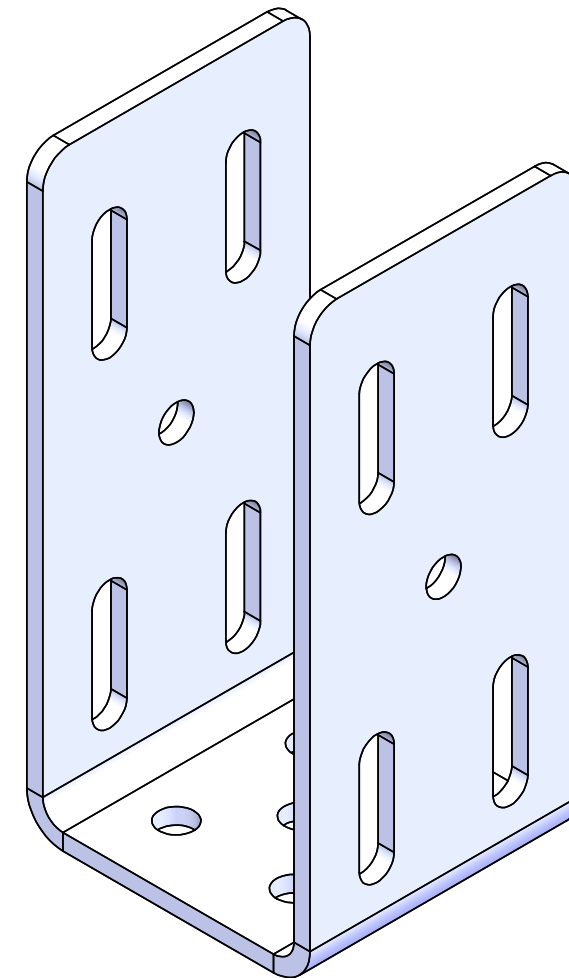
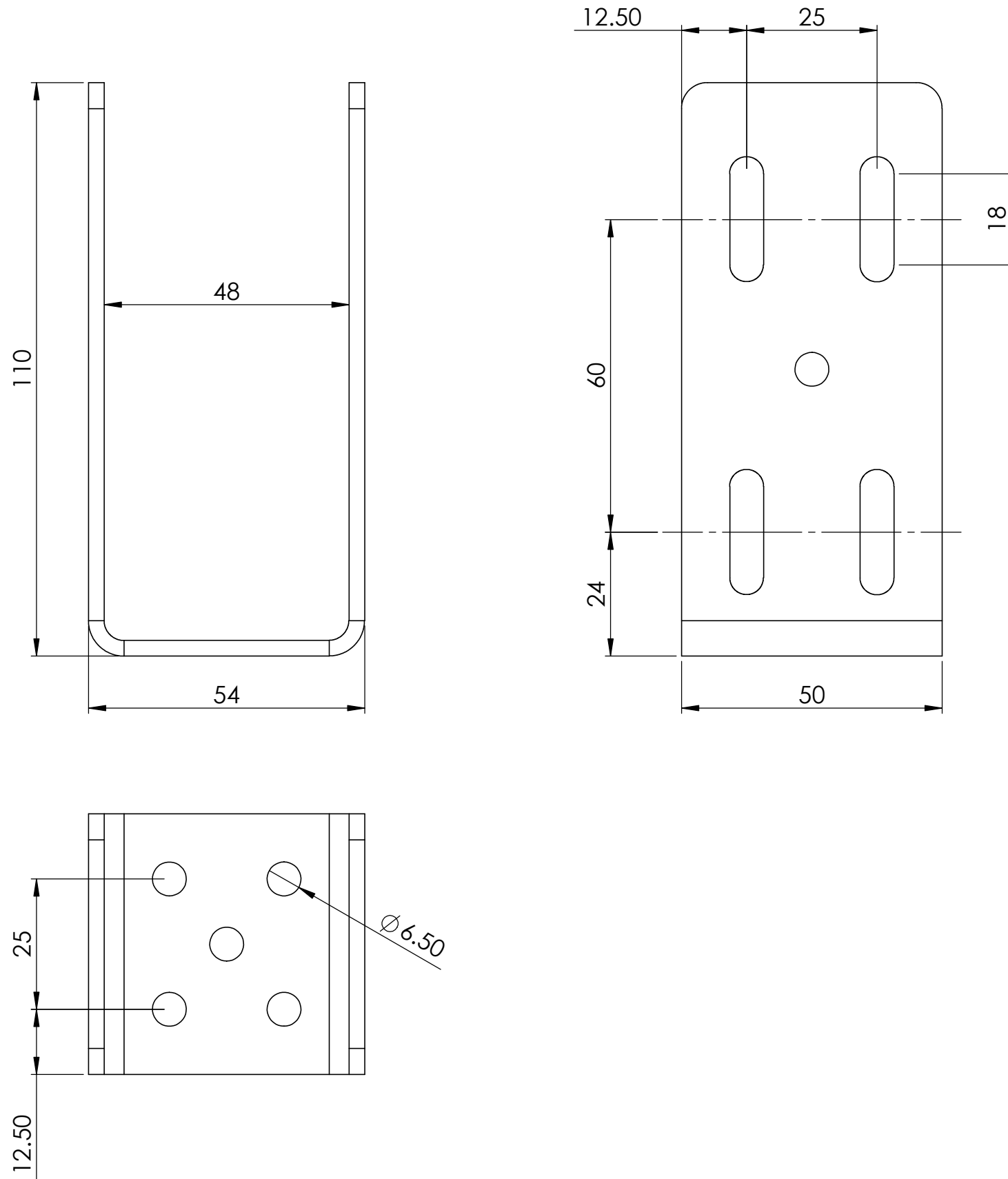

UGS
 PO Box 84 262,
 Westgate, Auckland
 0657 New Zealand
 Phone: +64 9 838 6429
 www.ugs.co.nz

Description and Notes:
 F150 Saddle Bracket - 50mm

Material:
 3mm ALUMINIUM

Finish:
 POWDER COAT

Vendor:

Vendor Ref:

Weight (Kg):

Area (m2):

Design by: Peter Herrick

Drawn by: G.Termeh

Units: Metric (mm & Kg)

Scale: N/A

Date: 3/4/2022

Sheet: 1 of 3

Drawing No.

Rev: