

H-RAIL

HORIZONTAL RAIL SYSTEM

TO ALWAYS WORK ON THE RIGHT RAIL.

The H-Rail system is a safe and versatile horizontal rigid rail system that can be installed using only a few fasteners. Thanks to its modular design, curved or straight rail systems can be assembled. H-RAIL is suitable for fall protection, restraint and suspension work. Sliding devices are available for different applications: choose the one that suits you and operate safely with H-RAIL!



H-RAIL | overview

H-RAIL ON FLOOR

HORIZONTAL RAIL SYSTEM

EN
795:2012 D

CEN/TS
16415:2013

UNI
11578:2015
D

AS/NZS
1891.2:2001

AS/NZS
1891.4:2009

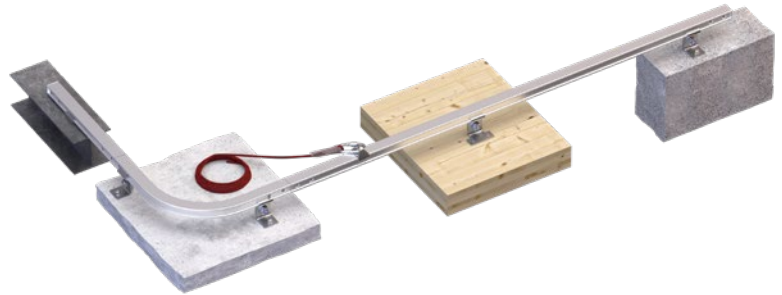

H-RAIL + TOWER/ TOWER A2/TOWER XL

HORIZONTAL RAIL SYSTEM
ON SUPPORTS

EN
795:2012 D

CEN/TS
16415:2013

UNI
11578:2015
D

AS/NZS
1891.2:2001

AS/NZS
1891.4:2009



H-RAIL OVERHEAD

HORIZONTAL OVERHEAD RAIL SYSTEM

EN
795:2012 D

CEN/TS
16415:2013

UNI
11578:2015
D

AS/NZS
1891.2:2001

AS/NZS
1891.4:2009



H-RAIL ON WALL

HORIZONTAL WALL-MOUNTED
RAIL SYSTEM

EN
795:2012 D

CEN/TS
16415:2013

UNI
11578:2015
D

AS/NZS
1891.2:2001

AS/NZS
1891.4:2009

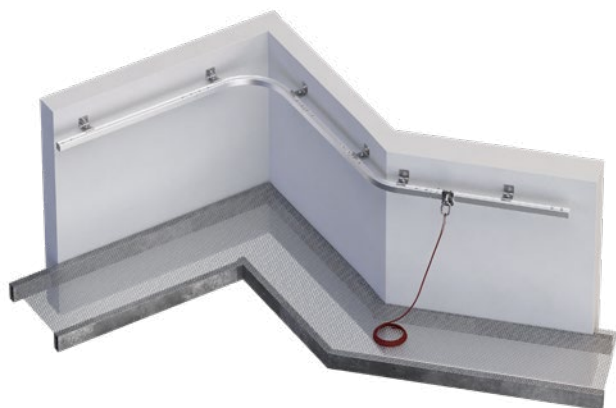

H-RAIL ON FLOOR

HORIZONTAL RAIL SYSTEM



LOW PROFILE

The reduced height of the rail system on the roof provides a minimal visual impact.

COMPLETE

The system can be used for different applications by selecting different sliding devices.

FAST INSTALLATION

Assembly requires a limited number of fastening points with support spacing up to 6 m.



LOAD DIRECTION



TYPES OF APPLICATION

▼ Installation of H-RAIL rail on flat roof for use as a walkway for the maintenance of a photo-voltaic system.



H-RAIL COMPONENTS

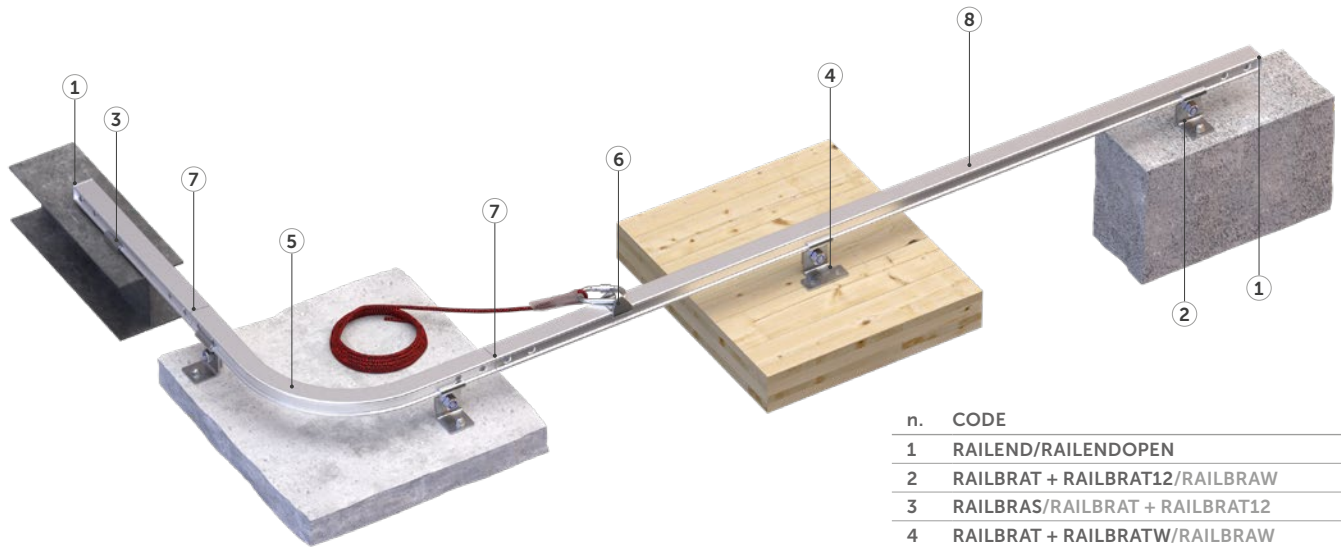

n.	CODE
1	RAILEND/RAILENDOPEN
2	RAILBRAT + RAILBRAT12/RAILBRAW
3	RAILBRAS/RAILBRAT + RAILBRAT12
4	RAILBRAT + RAILBRATW/RAILBRAW
5	RAILC90/RAILC120/RAIL135/RAILC150
6	RAILSLIDE/RAILSLIDEWALL
7	RAILJUN
8	RAIL3000

TECHNICAL DATA*

substructure	minimum thickness	support	fastening
GL24h	160 mm	RAILBRAT + RAILBRATW RAILBRAW	VGS Ø11/VGS EVO Ø11
CLT	160 mm	RAILBRAT + RAILBRATW RAILBRAW	VGS Ø13/VGS EVO Ø13
C20/25	140 mm	RAILBRAT + RAILBRAT12 RAILBRAW	AB1 Ø12/VIN-FIX + rod M12/SKR-CE Ø12
S235JR	5 mm	RAILBRAT + RAILBRAT12 RAILBRAS	M12 bolt + M12 self-locking nut M10 countersunk head bolt + M10 self-locking nut

work method	max. spacing between the supports [m]	max. no. of operators per system	recommended max. no. of operators per span
fall protection/ restraint	6	4	4

* The values indicated are the result of experimental tests carried out under the supervision of third parties in accordance with the standard referred to. For a calculation report with minimum distances according to the relevant standard requirements, the substructure must be checked by a qualified engineer before installation.

RAILSLIDE

Universal sliding device for rail with excellent sliding properties through polyamide bits. Locking screw included.



RAILBRAT + RAILBRAT12

Universal supports for maximum versatility and convenience in mounting on different substrates.



RAILENDOPEN

Opening end stop, allowing entry and exit from the system.



RAIL3000

Available anodised on request.

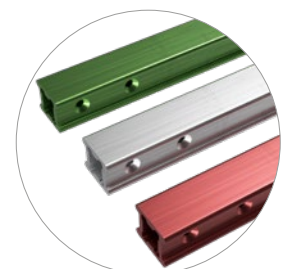

H-RAIL + TOWER/TOWER A2/TOWER XL

HORIZONTAL RAIL SYSTEM ON SUPPORTS



COMPATIBLE

It can be assembled in combination with TOWER, TOWER A2 and TOWER XL supports.

FUNCTIONAL

The combination with TOWER, TOWER A2 and TOWER XL raises the rail to overcome obstacles in the roof.

EASY

The rail is simply mounted on the TOWER, TOWER A2 and TOWER XL supports using the dedicated plate.

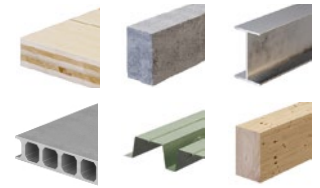

LOAD DIRECTION



TYPES OF APPLICATION



VIDEO



MANUALS



▼ Installation of H-RAIL rail with TOWER supports on a flat, insulated concrete roof.



H-RAIL COMPONENTS

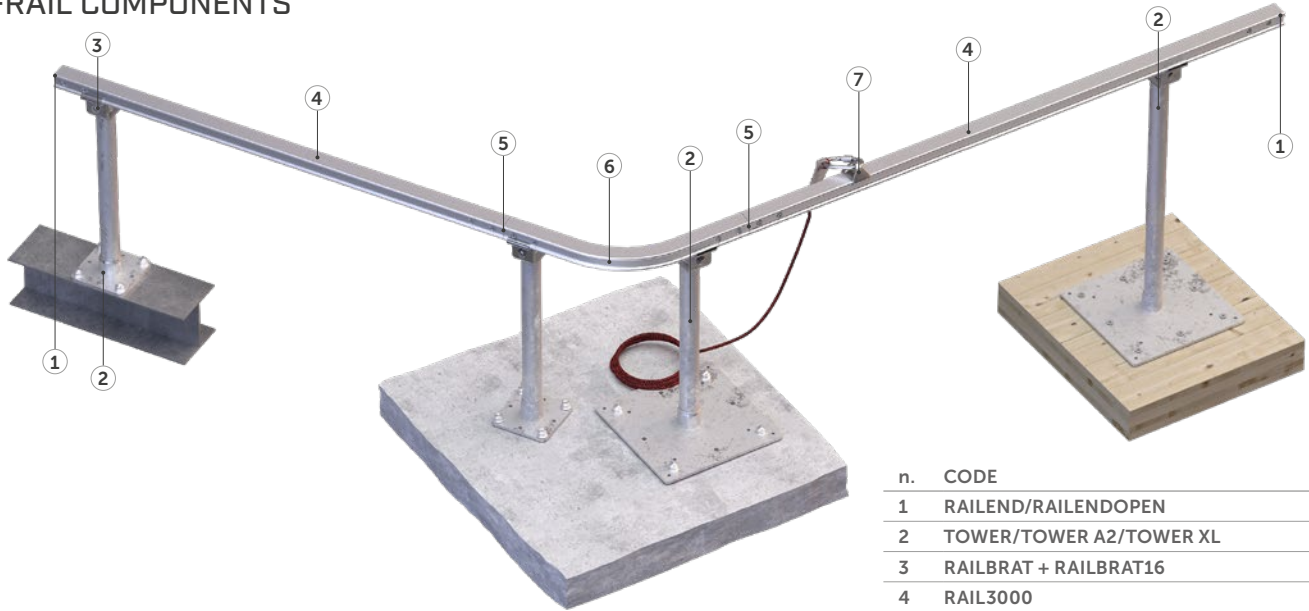

n.	CODE
1	RAILEND/RAILENDOPEN
2	TOWER/TOWER A2/TOWER XL
3	RAILBRAT + RAILBRAT16
4	RAIL3000
5	RAILJUN
6	RAILC120/RAILC90/RAILC135/RAILC150
7	RAILSLIDE/RAILSLIDEWALL

TECHNICAL DATA*

substructure	minimum thickness	TOWER/TOWER A2 fastening	rail supports	substructure	minimum thickness	TOWER XL fastening
GL24h	160 x 160 mm	VGS Ø9	RAILBRAT + RAILBRAT16	CLT	100 mm	VGS Ø11
CLT	200 mm	VGS Ø9		C20/25	110 mm	AB7 Ø10
C20/25	140 mm	AB1 Ø12				rod Ø10
		rod Ø12				VIN-FIX
		SKR-CE Ø12				SKR CE Ø10
S235JR	6 mm	VIN-FIX/HYB-FIX	C45/55	30 mm	BEFTOWERXL1	
		EKS + ULS + MUT		0,75 mm	TRAPO set	

work method	max. spacing between the supports [m]	max. no. of operators per system	recommended max. no. of operators per span
fall protection/restraint	6	4	4

* The values indicated are the result of experimental tests carried out under the supervision of third parties in accordance with the standard referred to. For a calculation report with minimum distances according to the relevant standard requirements, the substructure must be checked by a qualified engineer before installation.



RAILC90, RAILC120, RAILC135, RAILC150

H-RAIL includes bends with different angles to meet specific installation requirements.



RAILJUN

Universal rail joint. Simple to install. Excellent coupling with RAIL3000. Concealed after installation.

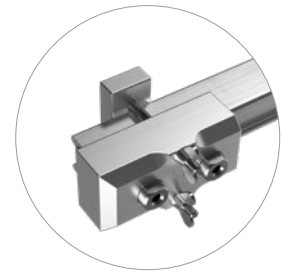

RAILJUNTOOL

Template for drilling holes for the RAILJUN joint, RAILEND, and RAILENDOPEN end stop. Required for rails cut to length on site.

I H-RAIL OVERHEAD

HORIZONTAL OVERHEAD RAIL SYSTEM



ADAPTABLE

The rail can be assembled on various substructures with the appropriate mounting plates.



FUNCTIONAL

Overhead application of the rail allows operators to work with their hands free and safely by using sliding and retractable devices.

SAFE

This system is also suitable and tested for suspended work for up to four simultaneous users.



LOAD DIRECTION



TYPES OF APPLICATION

▼ Installation of H-RAIL ceiling rail for suspended work for façade cleaning.



H-RAIL COMPONENTS

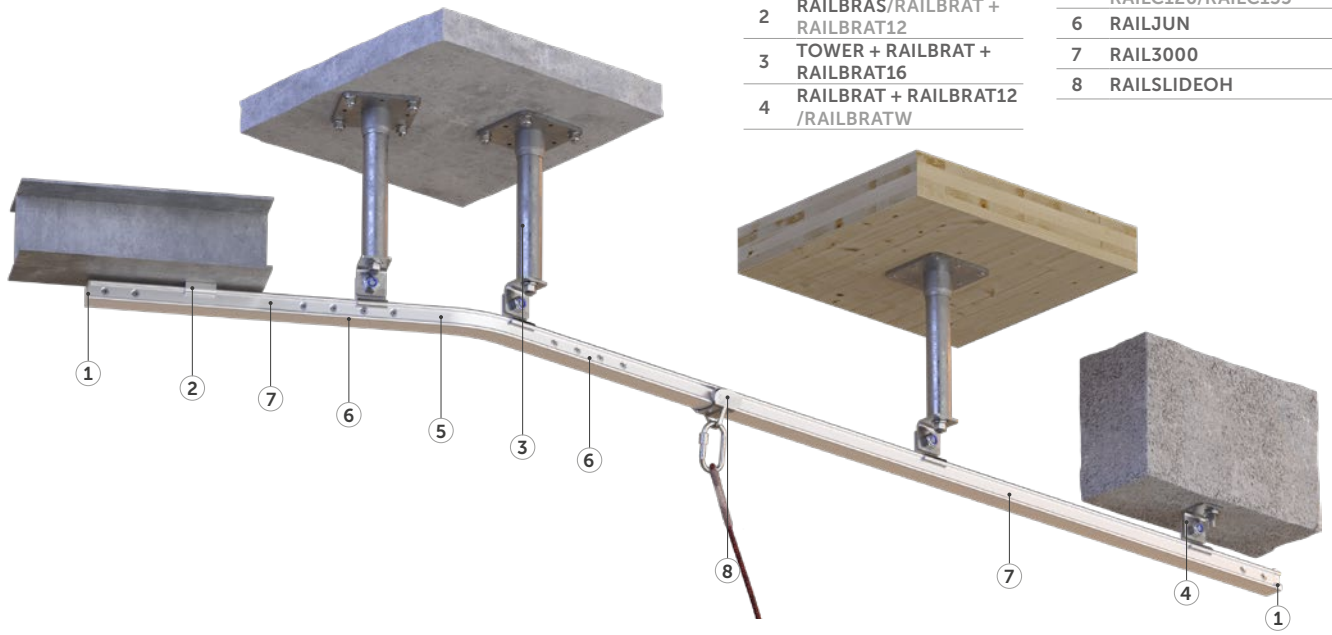

n.	CODE
1	RAILENDOPEN/RAILEND
2	RAILBRAS/RAILBRAT + RAILBRAT12
3	TOWER + RAILBRAT + RAILBRAT16
4	RAILBRAT + RAILBRAT12 /RAILBRATW

n.	CODE
5	RAILC150/RAILC90/RAILC120/RAILC135
6	RAILJUN
7	RAIL3000
8	RAILSLIDEOH

TECHNICAL DATA*

substructure	minimum thickness	support	fastening	TOWER/TOWER A2 fastening
GL24h	160 mm	RAILBRAT + RAILBRATW RAILBRAW	VGS Ø11/VGS EVO Ø11	-
	160 x 160 mm	RAILBRAT + RAILBRAT16	-	VGS Ø9
CLT	160 mm	RAILBRAT + RAILBRATW RAILBRAW	VGS Ø13/VGS EVO Ø13	-
	200 mm	RAILBRAT + RAILBRAT16	-	VGS Ø9
C20/25	140 mm	RAILBRAT + RAILBRAT12 RAILBRAW	AB1 Ø12/VIN-FIX + rod M12/SKR-CE Ø12	-
		RAILBRAT + RAILBRAT16	-	AB1 Ø12/rod Ø12/VIN-FIX/ HYB-FIX
		RAILBRAT + RAILBRAT12 RAILBRAS	M12 bolt + M12 self-locking nut	-
S235JR	5 mm	RAILBRAT + RAILBRAT12 RAILBRAS	M10 countersunk head bolt + M10 self-locking nut	-
	6 mm	RAILBRAT + RAILBRAT16	-	EKS + ULS + MUT

work method	max. spacing between the supports [m]	max. no. of operators per system	recommended max. no. of operators per span
fall protection/ restraint	6	4	4
suspension	2	4	2



RAILSLIDEOH

Sliding device for overhead fall protection applications and suspension work. Equipped with four wheels that ensure excellent sliding even under vertical load.



RAILBRAT + RAILBRAT12

Supports for overhead application. They allow a two-step installation by first installing the RAILBRAT12 support on the substructure and then attaching it to RAILBRAT already coupled with the RAIL3000 rail.

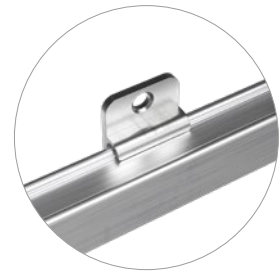

RAILBRAW

For H-RAIL installation on a timber or concrete substructure. Solution allowing installation close to the substructure, limiting standoff and reducing visual impact.

H-RAIL ON WALL

HORIZONTAL WALL-MOUNTED RAIL SYSTEM



AESTHETICS

Installed with low-profile mounting brackets for minimal visual impact.

COMFORT

Use with the specific sliding device equipped with four wheels.

MOUNTING

It can be assembled on different substructures (timber, concrete and steel) to suit all installation requirements.



LOAD DIRECTION



TYPES OF APPLICATION

▼ Installation of H-RAIL wall rail for façade maintenance.



H-RAIL COMPONENTS

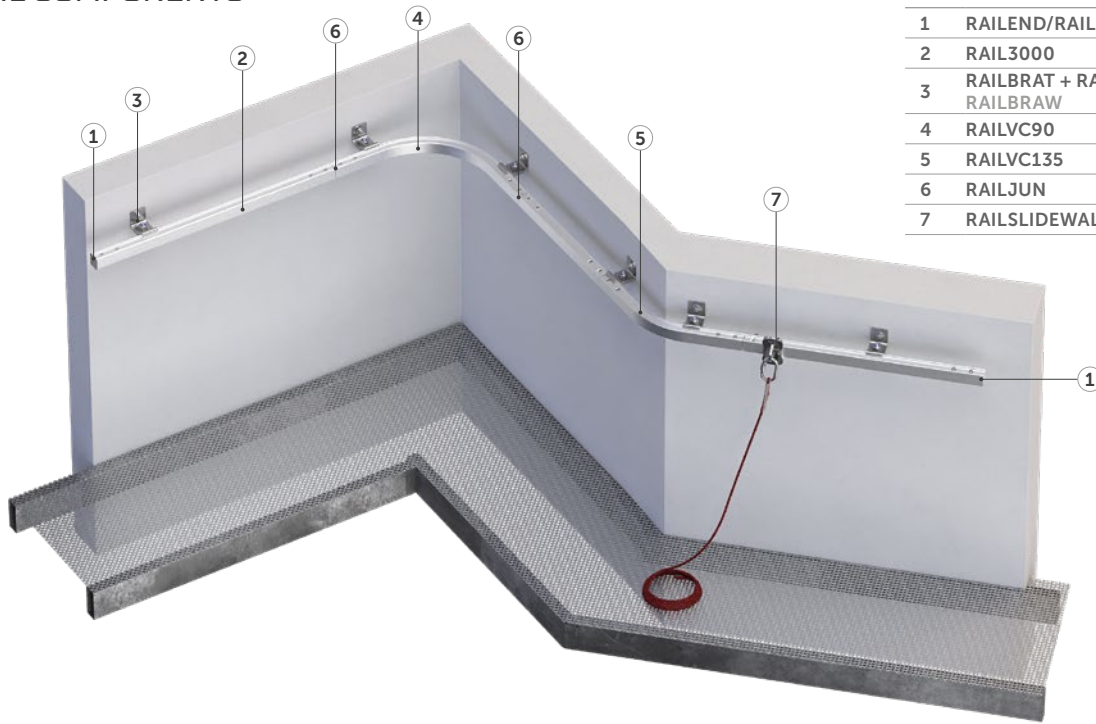

n.	CODE
1	RAILEND/RAILENDOPEN
2	RAIL3000
3	RAILBRAT + RAILBRATW/ RAILBRAW
4	RAILVC90
5	RAILVC135
6	RAILJUN
7	RAILSLIDEWALL/RAILSLIDE

TECHNICAL DATA*

substructure	minimum thickness	support	fastening
GL24h	160 mm	RAILBRAT + RAILBRATW RAILBRAW	VGS Ø11/VGS EVO Ø11
CLT	160 mm	RAILBRAT + RAILBRATW RAILBRAW	VGS Ø13/VGS EVO Ø13
C20/25	140 mm	RAILBRAT + RAILBRAT12 RAILBRAW	AB1 Ø12/VIN-FIX + rod M12/SKR-CE Ø12
S235JR	5 mm	RAILBRAT + RAILBRAT12 RAILBRAS	M12 bolt + M12 self-locking nut M10 countersunk head bolt + M10 self-locking nut

work method	max. spacing between the supports [m]	max. no. of operators per system	recommended max. no. of operators per span
fall protection/ restraint	6	4	4

* The values indicated are the result of experimental tests carried out under the supervision of third parties in accordance with the standard referred to. For a calculation report with minimum distances according to the relevant standard requirements, the substructure must be checked by a qualified engineer before installation.

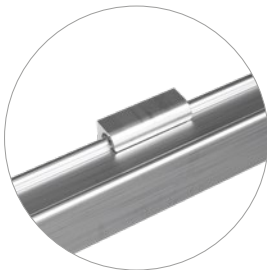

RAILBRAS

H-RAIL can be installed with the RAILBRAS support to steel substructures. The support requires only one fastener and has a very low visual impact.



RAILSLIDEWALL

Sliding device for wall application. Suitable for fall protection. Equipped with four wheels for excellent sliding even under load.



RAILVC90, RAILVC135

H-RAIL includes bends for wall application and different angles to meet specific application requirements.

H-RAIL | components

MAIN COMPONENTS FOR HORIZONTAL RAIL

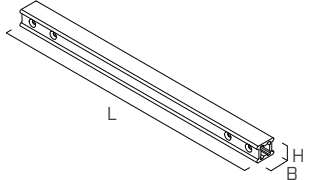
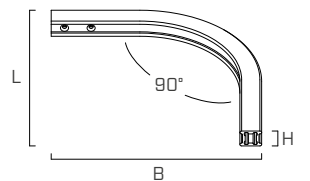
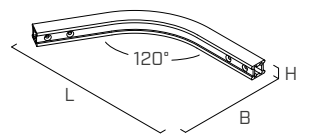
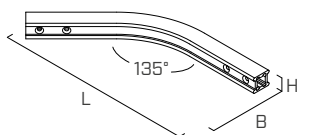
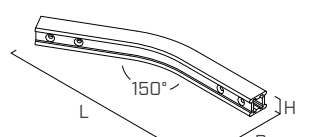
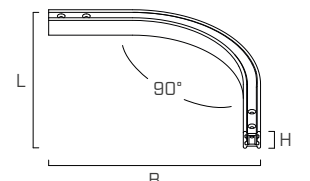
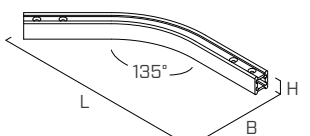

GROUP	CODE	description	material	d ₁ [mm]	B [mm]	H [mm]	L [mm]	pcs	
RAIL	RAIL3000	3 m aluminium rail	EN AW 6063 (T6)	-	49	41	3000	1	
	RAILC90	aluminium 90° bend for rail	EN AW 6063 (T6)	-	475	41	475	1	
	RAILC120	aluminium 120° bend for rail	EN AW 6063 (T6)	-	335	41	538	1	
	RAILC135	aluminium 135° bend for rail	EN AW 6063 (T6)	-	257	41	536	1	
	RAILC150	aluminium 150° bend for rail	EN AW 6063 (T6)	-	180	41	511	1	
	RAILVC90	aluminium vertical 90° bend for rail	EN AW 6063 (T6)	-	506	49	506	1	
	RAILVC135	aluminium vertical 135° bend for rail	EN AW 6063 (T6)	-	260	49	558	1	

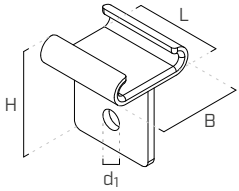
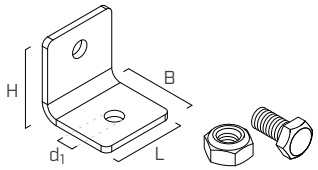
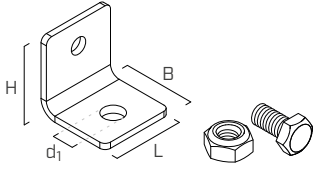
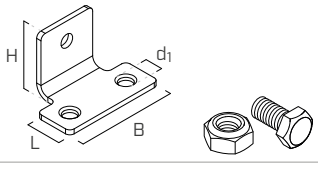
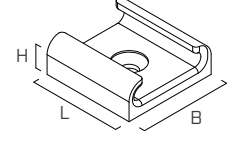
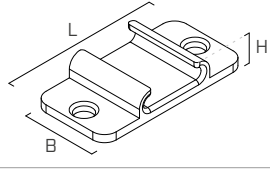
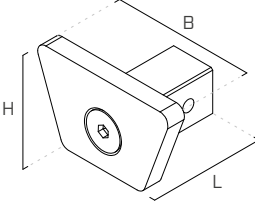
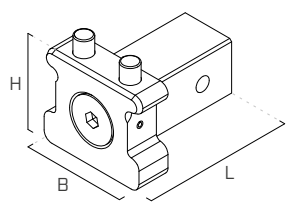
MAIN COMPONENTS FOR HORIZONTAL RAIL

GROUP	CODE	description	material	d_1	B	H	L	pcs	
				[mm]	[mm]	[mm]	[mm]		
INTERMEDIATE SUPPORT	RAILBRAT	coupled support upper element with hole $d_1=13,5$ mm to combine with RAILBRAT12, RAILBRAT16 or RAILBRATW	AISI 304 stainless steel grade 1.4301	12,5	60	74	60	1	
	RAILBRAT12	coupled support bottom element M12 fastener for RAILBRAT included	AISI 304 stainless steel grade 1.4301	12,5	60	63	60	1	
	RAILBRAT16	coupled support bottom element M16 fastener for RAILBRAT included	AISI 304 stainless steel grade 1.4301	16,5	60	63	60	1	
	RAILBRATW	coupled support bottom element for installation on timber. Fastener for RAILBRAT included	AISI 304 stainless steel grade 1.4301	14	103	63	60	1	
	RAILBRAS	support for installation on steel	AISI 304 stainless steel grade 1.4301	-	60	22	60	1	
	RAILBRAW	support for installation on timber and concrete	AISI 304 stainless steel grade 1.4301	-	60	22	120	1	
TERMINAL ELEMENT	RAILEND	fixed end element	AISI 304 stainless steel grade 1.4301	-	85	49	55	1	
	RAILENDOPEN	opening end element	AISI 304 stainless steel grade 1.4301	-	49	49	60	1	

H-RAIL | components

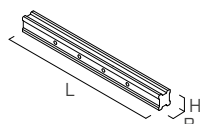
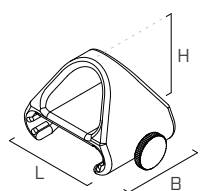
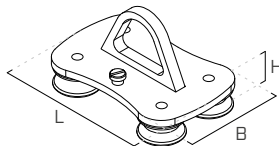
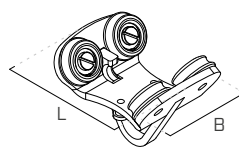
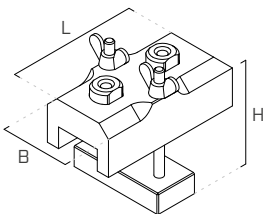
MAIN COMPONENTS FOR HORIZONTAL RAIL

GROUP	CODE	description	material	d ₁ [mm]	B [mm]	H [mm]	L [mm]	pcs	
JOINT	RAILJUN	joint element for rail	EN AW 6082	-	29	33	340	1	
SLIDING DEVICE	RAILSLIDE	sliding device	AISI 304 stainless steel grade 1.4301 and polyamide (PA)	-	51	50	70	1	
	RAILSLIDEWALL	sliding device for wall application	AISI 304 stainless steel grade 1.4301	-	69	73	111	1	
	RAILSLIDEOH	sliding device for overhead applications and suspended work	AISI 304 stainless steel grade 1.4301	-	70	72	95	1	
TOOL	RAILJUNTOOL	template for rail junction holes	EN AW 6082 1.1191 (C45E) aluminium	-	92	116	132	1	
	RAILPLATE	identification plate for H-RAIL (languages: Italian, English, German, French, Spanish)	AISI 304 stainless steel grade 1.4301	-	-	-	-	1	
FASTENING	RAILOCKSCREW	screw for RAILBRAT with knurled head for rail clamping	AISI 304 stainless steel grade 1.4301	-	-	-	-	1	
	RAILSCREW	fastening screws for RAILJUN, RAILEND and RAILENDOPEN. DIN 7991 M8x16 A2-70	A2-70	-	-	-	-	50	