

EUROSTYLE SPANLOK™ WALL CLADDING ON CAVITY JAMB FLASHING FOR VERTICAL CLADDING ON CAVITY (RECESSED WINDOW/DOOR OPTION 2)

Detail Number: RI-ESRWVC-130B

Date drawn: 11/06/2024

Scale: 1 : 5@ A4

BUILDING WRAP DRESSED INTO
OPENING AS PER E2/AS1

ROOFING INDUSTRIES
BACK
TRAY* FLASHING RUN
FROM TOP OF HEAD
FLASHING TO GROUND
OR EXIT POINT

HORIZONTAL DRAINED
CAVITY BATTEN

ROOFING INDUSTRIES
EUROSTYLE SPANLOK™

GRAB FLASHING RIVET FIXED TO PAN

ROOFING INDUSTRIES JAMB
FLASHING WITH RETURN FOLD

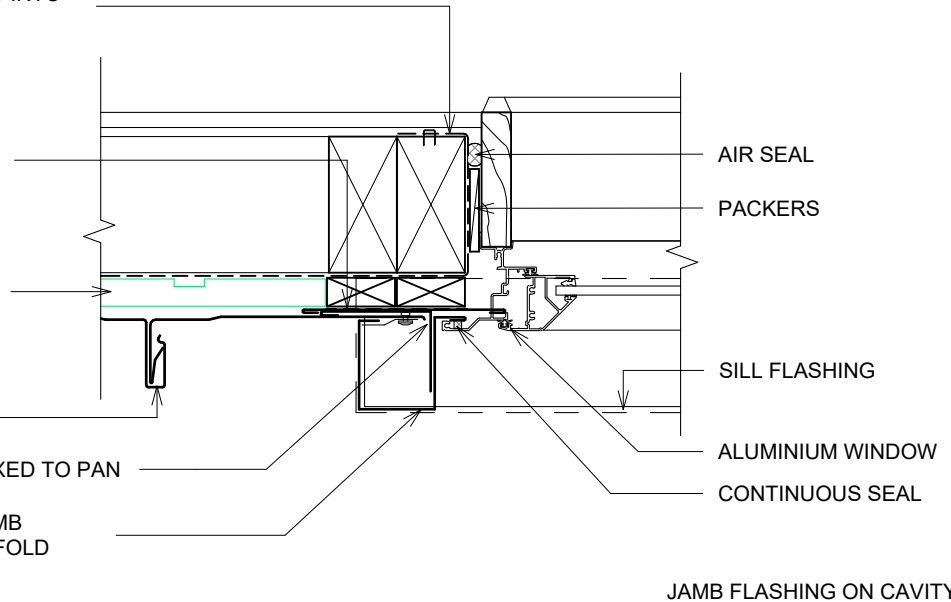

* Back tray size may require to increase to ensure coverage at ends of head flashings. Turn down end of head flashing

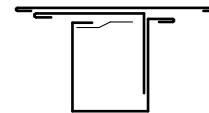

DETAIL ANNOTATION:

1. REFER TO E2/AS1 FOR GENERAL WINDOW OPENING FOR WRAPPING OF FRAMED OPENING PRIOR TO WINDOW INSTALLATION.
2. WINDOW PROFILE TO BE SELECTED TO ACHIEVE COVER SHOWN IN DETAILS.
3. ARCHITRAVE'S ARE SHOWN FOR CONSISTENCY ONLY, DETAIL MAY BE USED WITH REBATED LINER.
4. WHERE SUPPORT BRACKETS REQUIRED BY THE WINDOW MANUFACTURER TO CARRY THE FRAME AND GLAZING LOADS THEY MUST BE SUPPLIED AS AN INTEGRAL PART OF THE WINDOW MANUFACTURER'S RECOMMENDATIONS.
5. LIAISE WITH WINDOW MANUFACTURER PRIOR TO INSTALLATION
6. SEAL HEAD FLASHING TO WINDOW IN VERY HIGH & EXTRA HIGH WIND ZONES
7. TREATED TIMBER CAVITY BATTENS CONTAINING CORROSIVE TREATMENTS MUST BE SEPARATED FROM METAL CLADDING CASTELLATED BATTEN OR APPROVED DRAINED BATTEN CAN BE USED WITH THIS SYSTEM
8. FASTENERS TO BE COMPATIBLE WITH MATERIAL BEING FIXED AND THE SUITABLE GRADE FOR THE ENVIRONMENT IN WHICH LOCATED
9. ALTERNATIVELY REFER TO E2/AS1 FOR FLASHING COVER GUIDANCE
11. CLIPS OMITTED FOR CLARITY

GENERAL NOTES:

- These details are to be read with Roofing Industries SPANLOK™ Product Technical Statement and installation guide.
- These details are generally in compliance with E2/AS1 and/or the NZ Metal Roof & Wall Cladding Code of Practice and in some cases specific details by 'Roofing Industries'.
- The building designer is ultimately responsible to ensure that details used meet the requirements of the NZ Building Code for the specific project.
- Details of the supporting structure including cavity battens are indicative only and are the responsibility of the building designer. For steel framed buildings thermal break cavity battens may be required.
- Roof/wall underlay selection are the responsibility of the designer. Underlay to be installed in accordance with underlay manufacturer's recommendations and requirements.
- These details are for Roofing Industries profile/s as nominated and may not be applicable to other profiles.
- This drawing is the copyright of 'Roofing Industries' and can only be copied or reproduced with their permission.
- Further information can be obtained from the NZ Metal Roof & Wall Cladding Code of Practice: www.metalroofing.org.nz or E2/AS1.
- Details are for steel based materials, other substrates may require some changes.
- All dimensions are nominal.

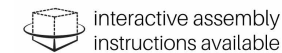

Copyright detail © 2024

<http://wksp.nz/ri-esl-bar>



Get **WORKINGSPEC** from
Apple App Store/Google Play

