

EUROSTYLE SPANLOK™ WALL CLADDING ON CAVITY SILL FLASHING FOR VERTICAL CLADDING ON CAVITY (RECESSED WINDOW/DOOR OPTION 1)

Detail Number: RI-ESRWVC-120C

Date drawn: 11/06/2024

Scale: 1 : 5@ A4

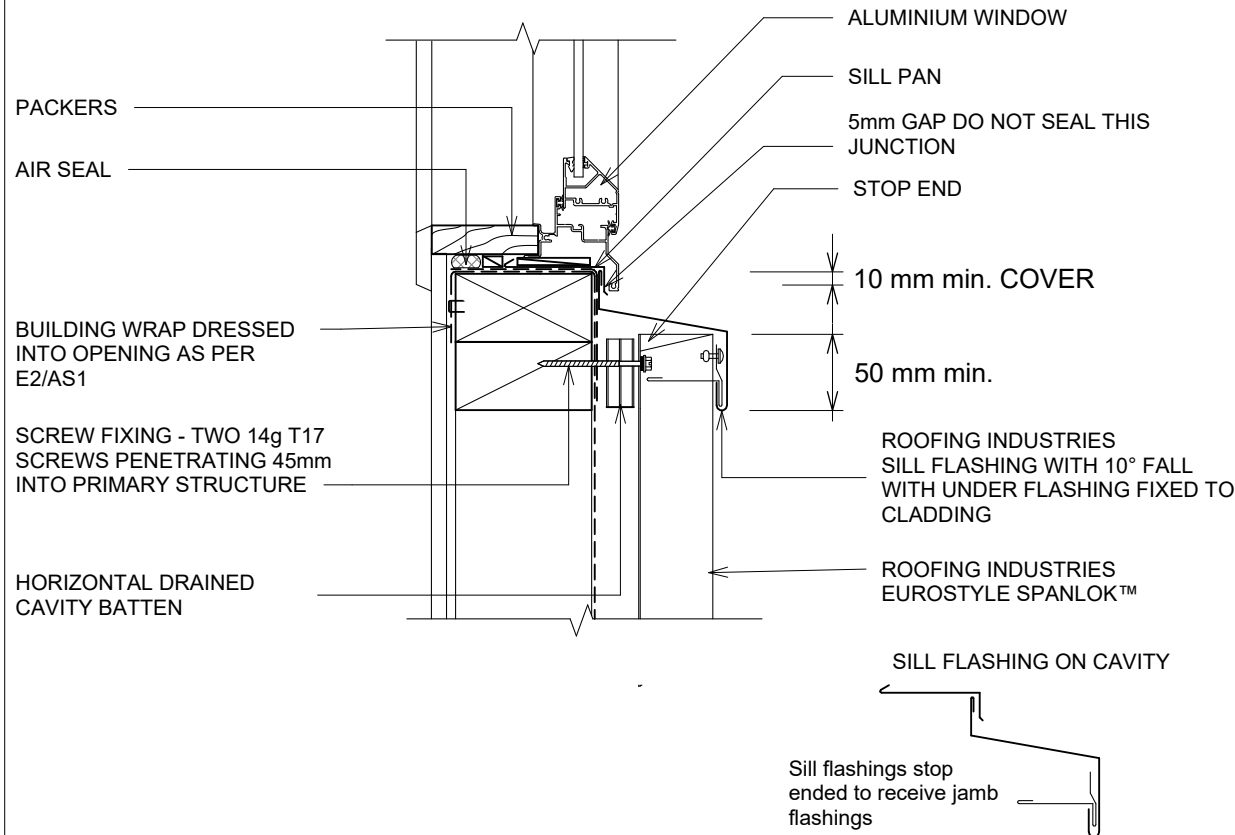

DETAIL ANNOTATION:

1. REFER TO E2/AS1 FOR GENERAL WINDOW OPENING FOR WRAPPING OF FRAMED OPENING PRIOR TO WINDOW INSTALLATION.
2. WINDOW PROFILE TO BE SELECTED TO ACHIEVE COVER SHOWN IN DETAILS.
3. ARCHITRAVE'S ARE SHOWN FOR CONSISTENCY ONLY, DETAIL MAY BE USED WITH REBATED LINER.
4. WHERE SUPPORT BRACKETS REQUIRED BY THE WINDOW MANUFACTURER TO CARRY THE FRAME AND GLAZING LOADS THEY MUST BE SUPPLIED AS AN INTEGRAL PART OF THE WINDOW MANUFACTURER'S RECOMMENDATIONS.
5. LIAISE WITH WINDOW MANUFACTURER PRIOR TO INSTALLATION
6. SEAL HEAD FLASHING TO WINDOW IN VERY HIGH & EXTRA HIGH WIND ZONES
7. TREATED TIMBER CAVITY BATTENS CONTAINING CORROSIVE TREATMENTS MUST BE SEPARATED FROM METAL CLADDING
8. CASTELLATED BATTEN OR APPROVED DRAINED BATTEN CAN BE USED WITH THIS SYSTEM
9. FASTENERS TO BE COMPATIBLE WITH MATERIAL BEING FIXED AND THE SUITABLE GRADE FOR THE ENVIRONMENT IN WHICH LOCATED
10. ALTERNATIVELY REFER TO E2/AS1 FOR FLASHING COVER GUIDANCE
11. CLIPS OMITTED FOR CLARITY
12. HIGH TO EXTRA HIGH WIND ZONES DOUBLE FIX UNDERFLASHING

GENERAL NOTES:

- These details are to be read with Roofing Industries SPANLOK™ Product Technical Statement and installation guide.
- These details are generally in compliance with E2/AS1 and/or the NZ Metal Roof & Wall Cladding Code of Practice and in some cases specific details by 'Roofing Industries'.
- The building designer is ultimately responsible to ensure that details used meet the requirements of the NZ Building Code for the specific project.
- Details of the supporting structure including cavity battens are indicative only and are the responsibility of the building designer. For steel framed buildings thermal break cavity battens may be required.
- Roof/wall underlay selection are the responsibility of the designer. Underlay to be installed in accordance with underlay manufacturer's recommendations and requirements.
- These details are for Roofing Industries profile/s as nominated and may not be applicable to other profiles.
- This drawing is the copyright of 'Roofing Industries' and can only be copied or reproduced with their permission.
- Further information can be obtained from the NZ Metal Roof & Wall Cladding Code of Practice: www.metalroofing.org.nz or E2/AS1.
- Details are for steel based materials, other substrates may require some changes.
- All dimensions are nominal.

Copyright detail © 2024

