

EUROSTYLE SPANLOK™ WALL CLADDING ON PLYWOOD SUBSTRATE

WALL CLADDING BASE OF VERTICAL CLADDING ON CAVITY

Detail Number: RI-ESRWVP-050

Date drawn: 11/06/2024

Scale: 1 : 5@ A4

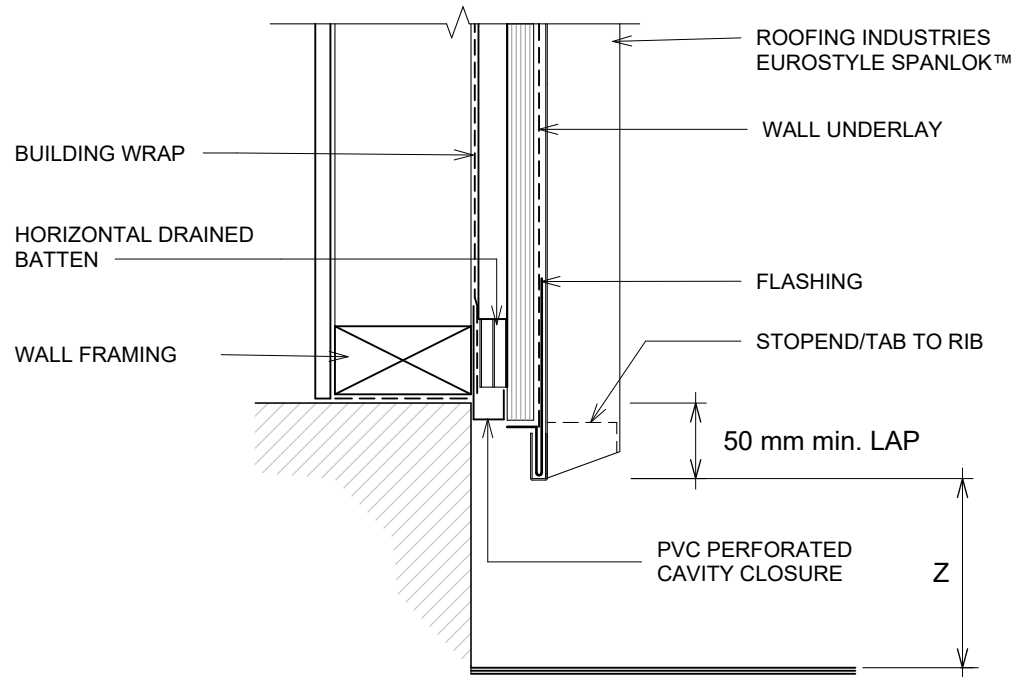

DETAIL ANNOTATION:

1. THE BOTTOM EDGE OF THE CLADDING SHALL OVERLAP THE FOUNDATION WALL
2. TREATED TIMBER CAVITY BATTENS CONTAINING CORROSIVE TREATMENTS MUST BE SEPARATED FROM METAL CLADDING
3. CASTELLATED BATTEN OR APPROVED DRAINED BATTEN CAN BE USED WITH THIS SYSTEM
4. FASTENERS TO BE COMPATIBLE WITH MATERIAL BEING FIXED AND THE SUITABLE GRADE FOR THE ENVIRONMENT IN WHICH LOCATED
5. CLIPS OMITTED FOR CLARITY

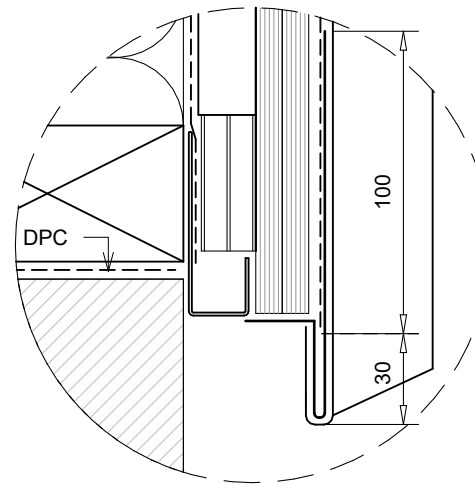

SET DOWN	MINIMUM
	Z
PAVED SURFACE	100mm
UNPAVED SURFACE	175mm

GENERAL NOTES:

- These details are to be read with Roofing Industries SPANLOK™ Product Technical Statement and installation guide.
- These details are generally in compliance with E2/AS1 and/or the NZ Metal Roof & Wall Cladding Code of Practice and in some cases specific details by 'Roofing Industries'.
- The building designer is ultimately responsible to ensure that details used meet the requirements of the NZ Building Code for the specific project.
- Details of the supporting structure including cavity battens are indicative only and are the responsibility of the building designer. For steel framed buildings thermal break cavity battens may be required.
- Roof/wall underlay selection are the responsibility of the designer. Underlay to be installed in accordance with underlay manufacturer's recommendations and requirements.
- These details are for Roofing Industries profile/s as nominated and may not be applicable to other profiles.
- This drawing is the copyright of 'Roofing Industries' and can only be copied or reproduced with their permission.
- Further information can be obtained from the NZ Metal Roof & Wall Cladding Code of Practice: www.metalroofing.org.nz or E2/AS1.
- Details are for steel based materials, other substrates may require some changes.
- All dimensions are nominal.

Copyright detail © 2024

