

Bill of Materials (BOM)				
Item	Part No.	Title	Material	Qty.
1		TEKAPO BASE COVER	PRESSED SS	1
2		TEKAPO INSERT	ABS	1
3		TEKAPO LOAD PLATE	AISI 304	1
4		TEKAPO SPIGGOT	CAST 2205 DUPLEX SS	1
5		M10x12 Grub Screw	EDST	2

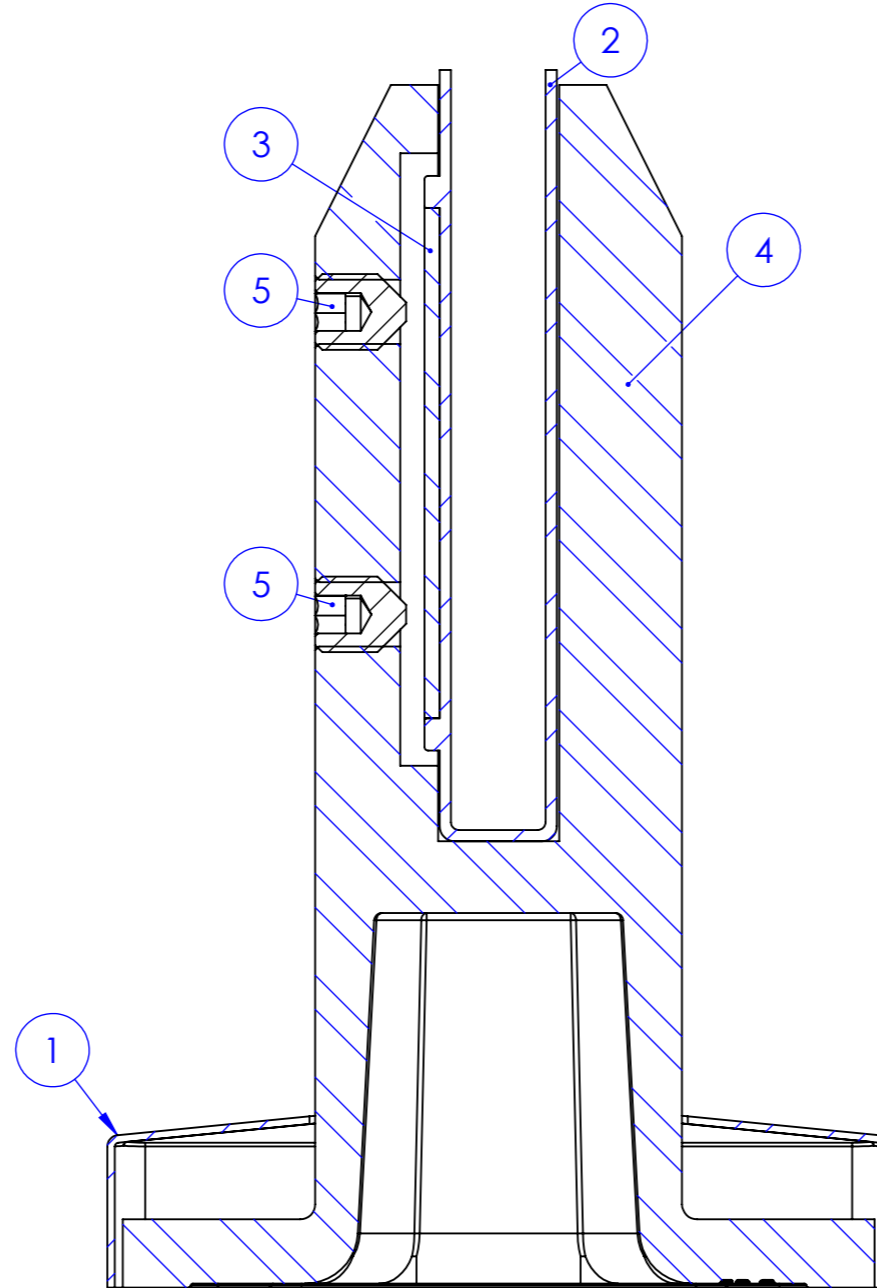

SECTION F-F

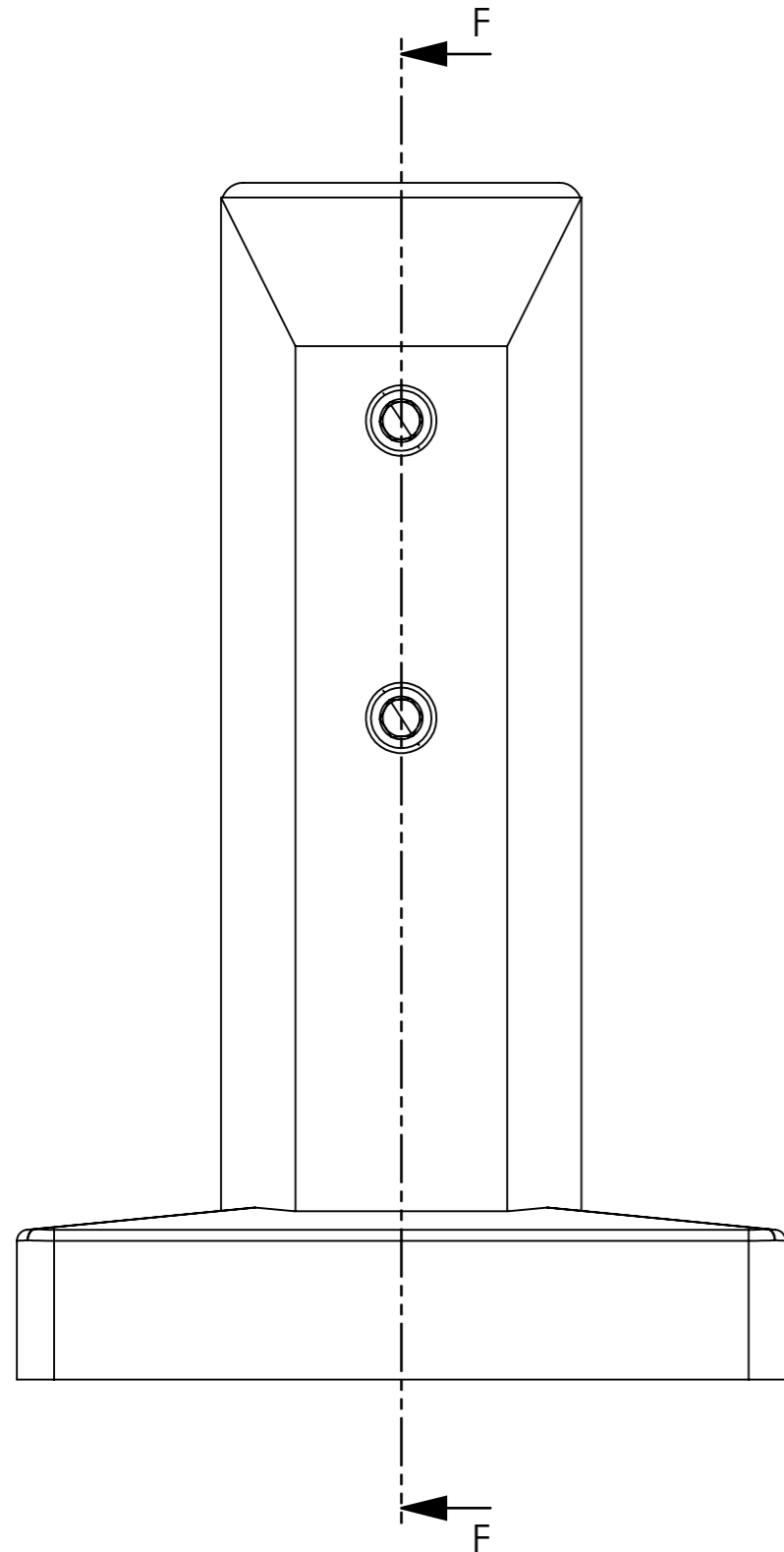
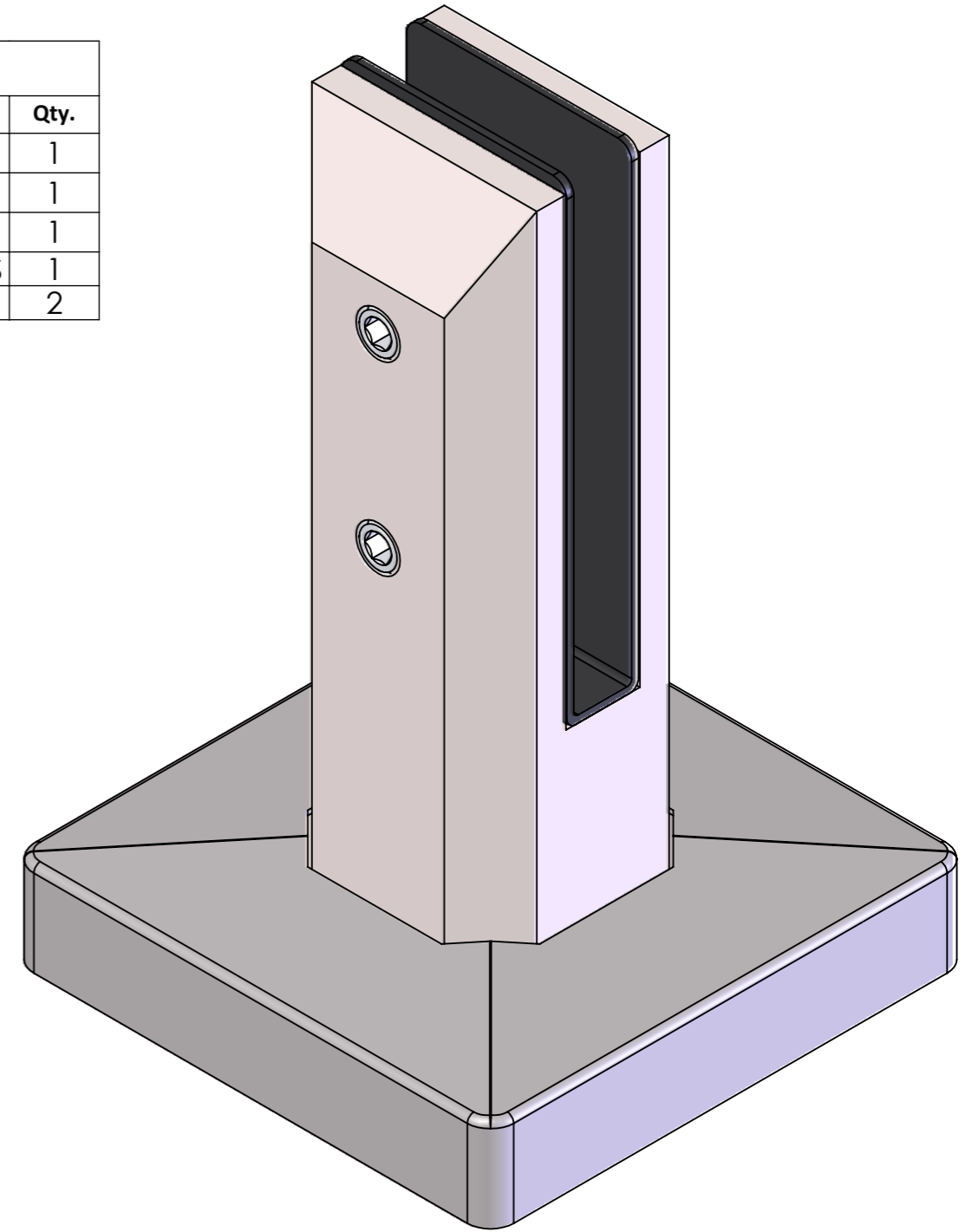

TOLERANCES 0 ±0.5mm 0.0 ±0.1mm 0.00 ±0.02mm ANGLE ±0.5° UNLESS OTHERWISE STATED	THE INFORMATION CONTAINED IN THIS DRAWING IS PROPRIETARY TO STORETECH AND SHALL NOT BE REPRODUCED OR DISCLOSED IN WHOLE OR IN PART OR USED FOR ANY DESIGN OR MANUFACTURE EXCEPT WHEN SUCH USER POSSESSES DIRECT WRITTEN AUTHORIZATION FROM STORETECH LTD.	DRAWN BY: MvB	DATE: 29/12/2020	NOTES: Note1 Note2 Note3 Note4 Note5 Note6	MATERIAL: FINISH: POLISH EXT FACES	PHASE: PROCESS: TYPE:	DESCRIPTION: TEKAPO ASSEMBLY			
		CHECKED BY: DIMENSIONS ARE MILLIMETERS UNLESS OTHERWISE STATED. DO NOT SCALE DRAWING.	3RD ANGLE PROJECTION		SCALE: 1:1	SHEET: A3	SHEET: 1 OF 3	PART NUMBER:	REVISION: 1	

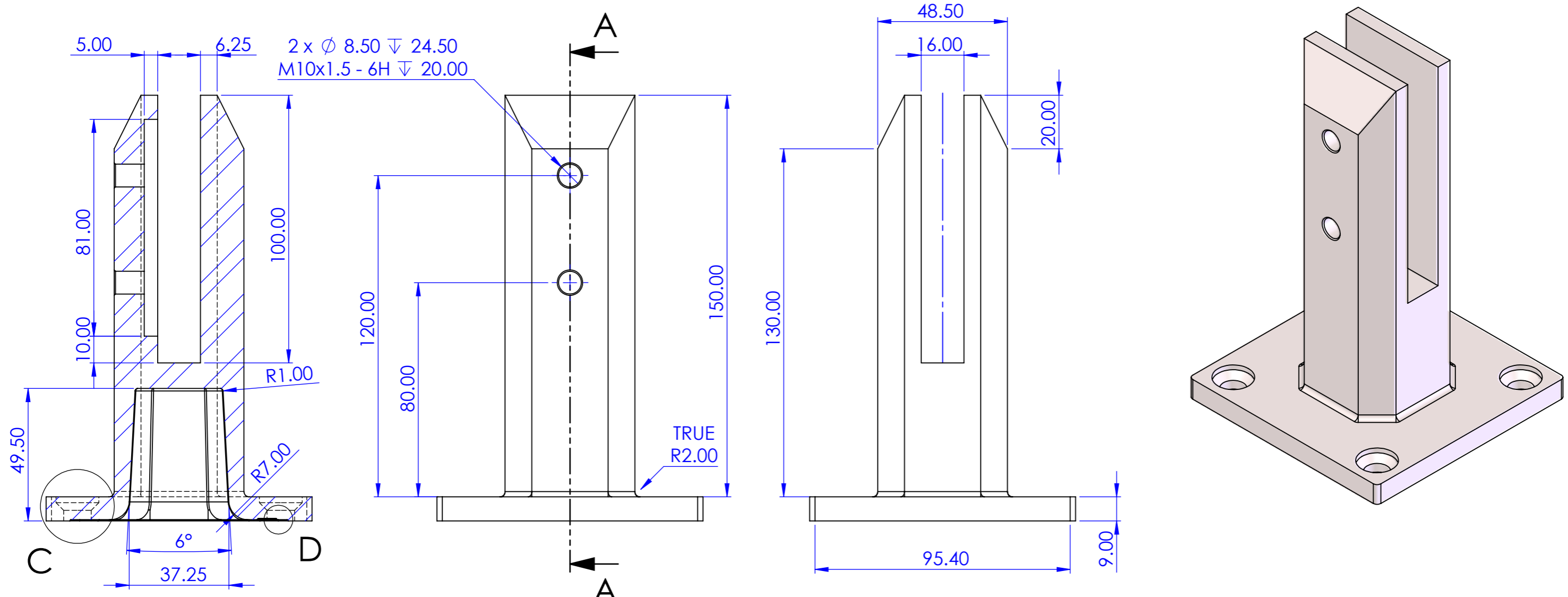

SECTION A-A

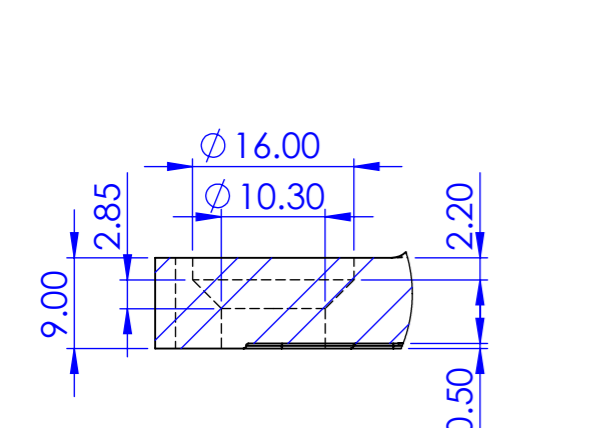

DETAIL C
SCALE 2 : 1.5

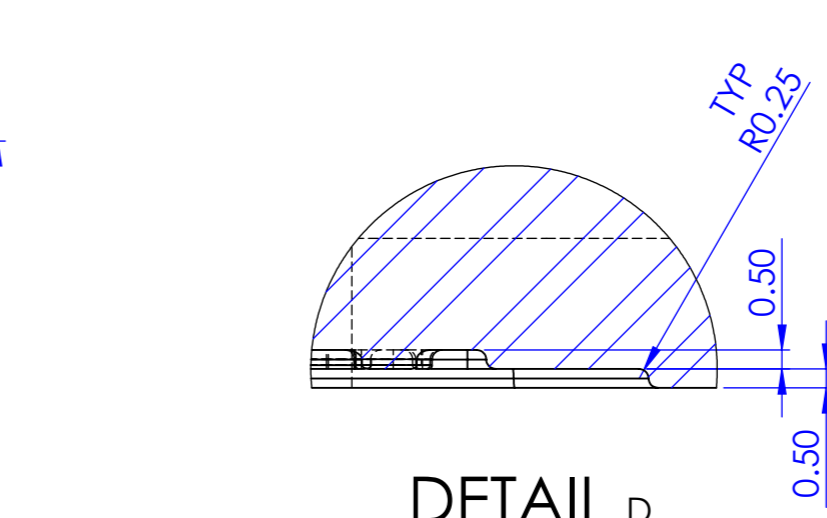
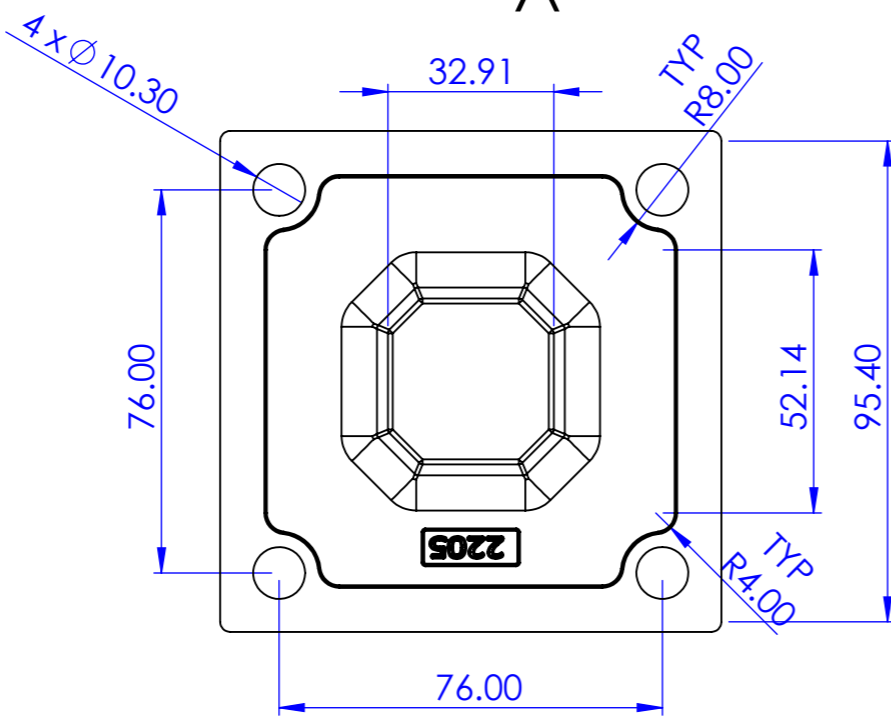

DETAIL D
SCALE 5 : 1

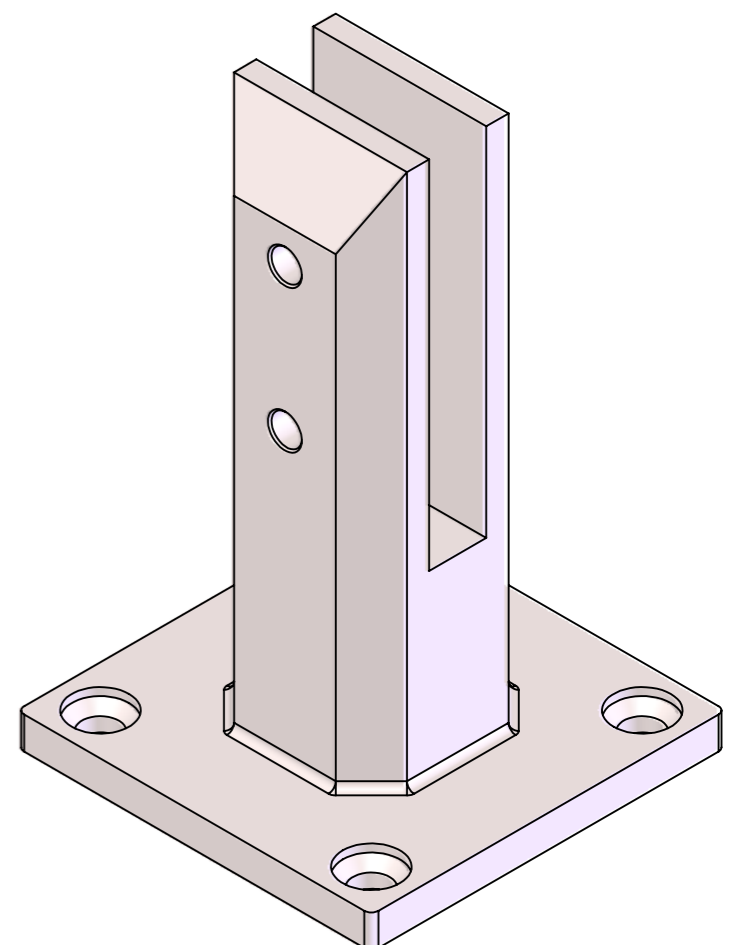

TOLERANCES O ±0.5mm O.O ±0.1mm O.OO ±0.02mm ANGLE ±0.5° UNLESS OTHERWISE STATED	THE INFORMATION CONTAINED IN THIS DRAWING IS PROPRIETARY TO STORETECH AND SHALL NOT BE REPRODUCED OR DISCLOSED IN WHOLE OR IN PART OR USED FOR ANY DESIGN OR MANUFACTURE EXCEPT WHEN SUCH USER POSSESSES DIRECT WRITTEN AUTHORIZATION FROM STORETECH LTD.	DRAWN BY: MvB	DATE: 29/12/2020	NOTES: Note1 Note2 Note3 Note4 Note5 Note6	MATERIAL: 2205 SS	PHASE:	DESCRIPTION: TEKAPO ASSEMBLY			
		CHECKED BY:	3RD ANGLE PROJECTION		FINISH: POLISH EXT FACES	PROCESS:				

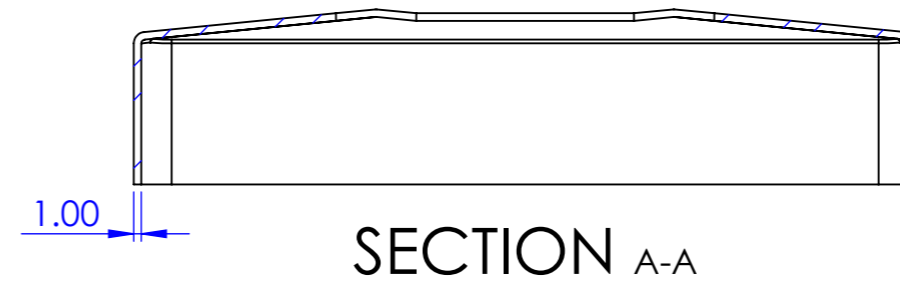
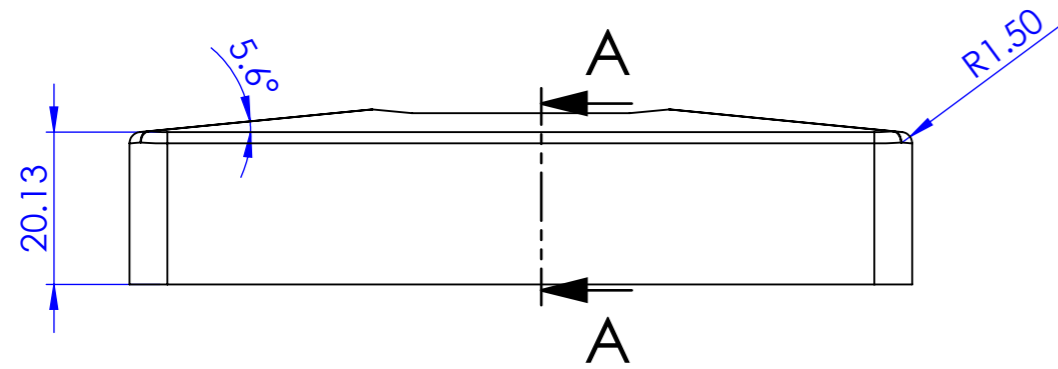
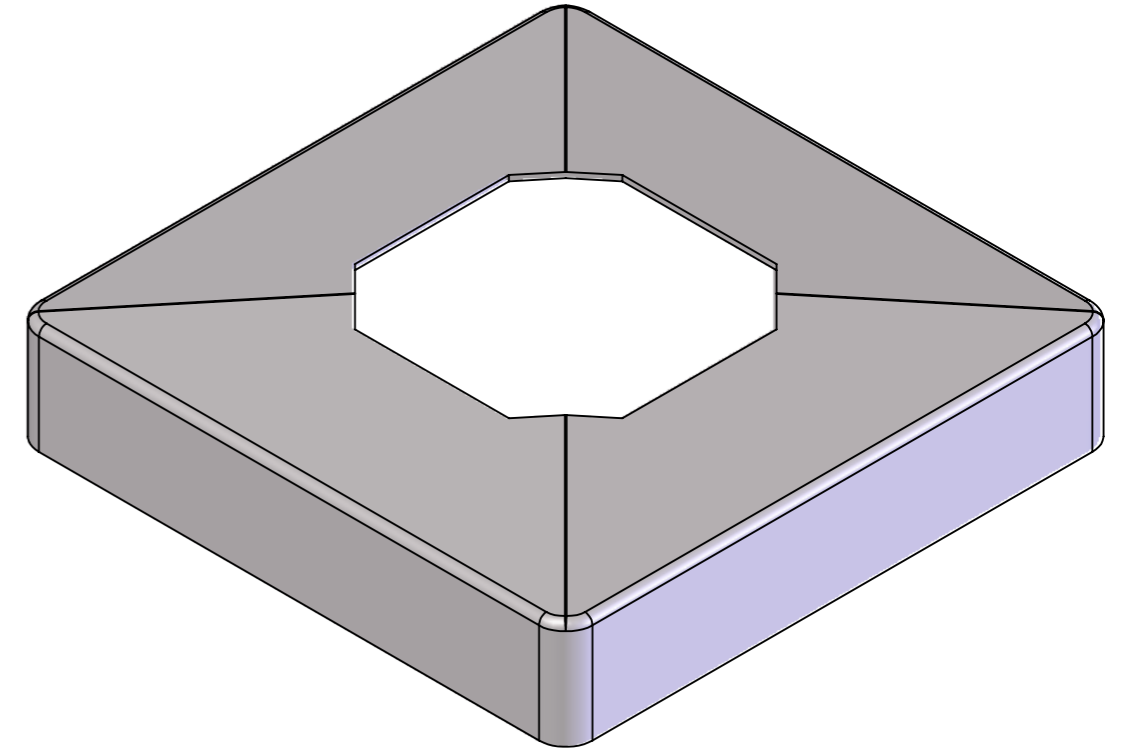
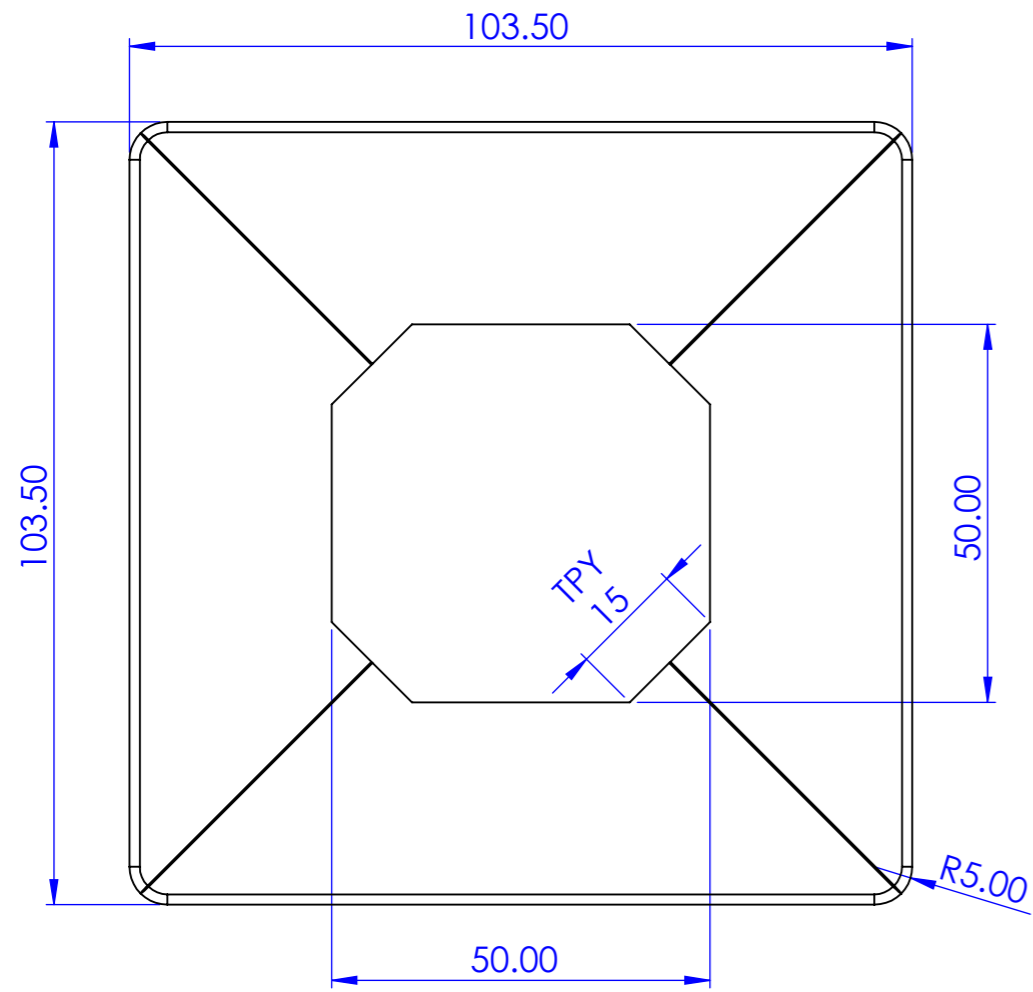

...make it your own!

TOLERANCES 0 ±0.5mm 0.0 ±0.1mm 0.00 ±0.02mm ANGLE ±0.5° UNLESS OTHERWISE STATED	THE INFORMATION CONTAINED IN THIS DRAWING IS PROPRIETARY TO STORETECH AND SHALL NOT BE REPRODUCED OR DISCLOSED IN WHOLE OR IN PART OR USED FOR ANY DESIGN OR MANUFACTURE EXCEPT WHEN SUCH USER POSSESSES DIRECT WRITTEN AUTHORIZATION FROM STORETECH LTD.	DRAWN BY: MvB	DATE: 29/12/2020	NOTES: Note1 Note2 Note3 Note4 Note5 Note6	MATERIAL: PRESSED SS	PHASE:	DESCRIPTION: TEKAPO BASE COVER			
		CHECKED BY:	3RD ANGLE PROJECTION		FINISH: CHROMED	PROCESS:				
DIMENSIONS ARE MILLIMETERS UNLESS OTHERWISE STATED. DO NOT SCALE DRAWING.					TYPE:					