



BelAire®
DESIGNER FENCING

...make it your own!

Tekapo Spigot PS1 - POOL FENCING

Structural Design Report, Job 20073
BelAire Designer Fencing – Extra high wind zone, various
locations. September 2023

PRODUCER STATEMENT – PS1 DESIGN



association of
consulting and
engineering



Building Code Clause(s):	B1, F2, F4	Job number: 20073
ISSUED BY: <i>(Engineering Design Firm)</i>	ExtraMile Consulting Ltd	
TO: <i>(Client)</i>	Storetech Industries Limited	
TO BE SUPPLIED TO: <i>(Building Consent Authority)</i>	Relevant Territorial Building Consent Authority	
IN RESPECT OF: <i>(Description of building work)</i>	Structural engineering design for proprietary pool fence system ('Tekapo' Fixing Spigot)	
AT: <i>(Address)</i>	Various sites within occupancy and wind limits as stated on drawings	
LEGAL DESCRIPTION	Varies	

We have been engaged by Storetech Industries Limited to provide:

structural engineering design for proprietary pool fence system

in respect of the requirements of the Clause(s) of the Building Code specified above for all of the proposed building work.

The design carried out by ExtraMile Consulting Ltd has been prepared in accordance with:

- ✓ compliance documents issued by the Ministry of Business, Innovation & Employment (Verification method /acceptable solution): B1/VM1

The proposed building work covered by this producer statement is described in the drawings specified in the attached Schedule, together with the specification, and other documents set out in the attached Schedule.

On behalf of ExtraMile Consulting Ltd, and subject to:

- site verification of the following design assumptions:
 - Occupancy as stated on the drawings
 - Wind zones as stated on the drawings
- all proprietary products meeting their performance specification requirements;

I believe on reasonable grounds that:

- the pool fence, if constructed in accordance with the drawings, specifications, and other documents provided or listed in the attached Schedule, will comply with the relevant provisions of the Building Code specified above; and that
- the persons who have undertaken the design have the necessary competence to do so.

I recommend the Nil level of construction monitoring.

Job Number: 20073

Job Address: Various sites within occupancy and wind limits as stated on drawings, and wind limits as stated on drawings
Compilation Date and Time: 25 September 2023 at 9:53 AM

I, Pawel Michal Milewski, am:

- CPEng number 1021657
- and hold the following qualifications: MEng(Hons)

ExtraMile Consulting Ltd holds a current policy of Professional Indemnity Insurance no less than \$200,000.

ExtraMile Consulting Ltd is not a member of ACE New Zealand.

SIGNED BY: Pawel Michal Milewski

(Signature):



Date: 25.06.2024

ON BEHALF OF: ExtraMile Consulting Ltd

Note: This statement has been prepared solely for Relevant Territorial Building Consent Authority and shall not be relied upon by any other person or entity. Any liability in relation to this statement accrues to ExtraMile Consulting Ltd only. As a condition of reliance on this statement, Relevant Territorial Building Consent Authority accepts that the total maximum amount of liability of any kind arising from this statement and all other statements provided to Relevant Territorial Building Consent Authority in relation to this building work, whether in tort or otherwise, is limited to the sum of \$200,000.

This form is to accompany **Form 2 of the Building (Forms) Regulations 2004** for the application of a Building Consent.

SCHEDULE TO PS1

Please include an itemised list of all referenced documents, drawings, or other supporting materials in relation to this producer statement below:

- [B2 Letter in Lieu - Design](#)
- [Engineering Drawing Set: 20073_Tekapo_Fixing_Spigot_Pool_Fence_R.5_Drgs TF01 to TF03](#)

GUIDANCE ON USE OF PRODUCER STATEMENTS

Information on the use of Producer Statements and Construction Monitoring Guidelines can be found on either the [ACE New Zealand](#) or [Engineering New Zealand](#) websites.

Producer statements were first introduced with the Building Act 1991. The producer statements were developed by a combined task committee consisting of members of the New Zealand Institute of Architects (NZIA), Institution of Professional Engineers New Zealand (now Engineering New Zealand), Association of Consulting and Engineering New Zealand (ACE NZ) in consultation with the Building Officials Institute of New Zealand (BOINZ). The original suite of producer statements has been revised at the date of this form to ensure standard use within the industry.

The producer statement system is intended to provide Building Consent Authorities (BCAs) with part of the reasonable grounds necessary for the issue of a Building Consent or a Code Compliance Certificate, without necessarily having to duplicate review of design or construction monitoring undertaken by others.

PS1 DESIGN: Intended for use by a suitably qualified independent engineering design professional in circumstances where the BCA accepts a producer statement for establishing reasonable grounds to issue a Building Consent;

PS2 DESIGN REVIEW: Intended for use by a suitably qualified independent engineering design review professional where the BCA accepts an independent design professional's review as the basis for establishing reasonable grounds to issue a Building Consent;

PS3 CONSTRUCTION: Forms commonly used as a certificate of completion of building work are Schedule 6 of NZS 3910:2013 or Schedules E1/E2 of NZIA's SCC 20112

PS4 CONSTRUCTION REVIEW: Intended for use by a suitably qualified independent engineering construction monitoring professional who either undertakes or supervises construction monitoring of the building works where the BCA requests a producer statement prior to issuing a Code Compliance Certificate.

This must be accompanied by a statement of completion of building work (Schedule 6).

The following guidelines are provided by ACE New Zealand and Engineering New Zealand to interpret the Producer Statement.

Competence of Engineering Professional

This statement is made by an engineering firm that has undertaken a contract of services for the services named, and is signed by a person authorised by that firm to verify the processes within the firm and competence of its personnel.

The person signing the Producer Statement on behalf of the engineering firm will have a professional qualification and proven current competence through registration on a national competence-based register such as a Chartered Professional Engineer (CPEng).

Membership of a professional body, such as Engineering New Zealand provides additional assurance of the designer's standing within the profession. If the engineering firm is a member of ACE New Zealand, this provides additional assurance about the standing of the firm.

Persons or firms meeting these criteria satisfy the term "suitably qualified independent engineering professional".

Professional Indemnity Insurance

As part of membership requirements, ACE New Zealand requires all member firms to hold Professional Indemnity Insurance to a minimum level.

The PI Insurance minimum stated on the front of this form reflects standard practice for the relationship between the BCA and the engineering firm.

Professional Services during Construction Phase

There are several levels of service that an engineering firm may provide during the construction phase of a project (CM1-CM5 for engineers³). The BCA is encouraged to require that the service to be provided by the engineering firm is appropriate for the project concerned.

Requirement to provide Producer Statement PS4

BCAs should ensure that the applicant is aware of any requirement for producer statements for the construction phase of building work at the time the building consent is issued. No design professional should be expected to provide a producer statement unless such a requirement forms part of ExtraMile Consulting Ltd's engagement.

Refer Also:

- 1 Conditions of Contract for Building & Civil Engineering Construction NZS 3910: 2013
- 2 NZIA Standard Conditions of Contract SCC 2011
- 3 Guideline on the Briefing & Engagement for Consulting Engineering Services (ACE New Zealand/Engineering New Zealand 2004)
- 4 PN01 Guidelines on Producer Statements

www.acenz.org.nz

www.engineeringnz.org

LETTER IN LIEU – DESIGN

To the Building Official,

Structural engineering design for proprietary pool fence system ('Tekapo' Fixing Spigot) at Various sites within occupancy and wind limits as stated on drawings, and wind limits as stated on drawings

COMPLIANCE WITH BUILDING CODE CLAUSE B2 – DURABILITY

The purpose of this letter is to demonstrate how compliance with Clause B2 (Durability) of the Building Code will be achieved for the above project. We can confirm that for specifically designed structural elements that are included within our design documentation:

Material	Means of Compliance	Details
Stainless Steel	B2/AS1	brackets and all fixings to be stainless steel

Yours faithfully,



Pawel Michal Milewski

For and on behalf of

ExtraMile Consulting Ltd

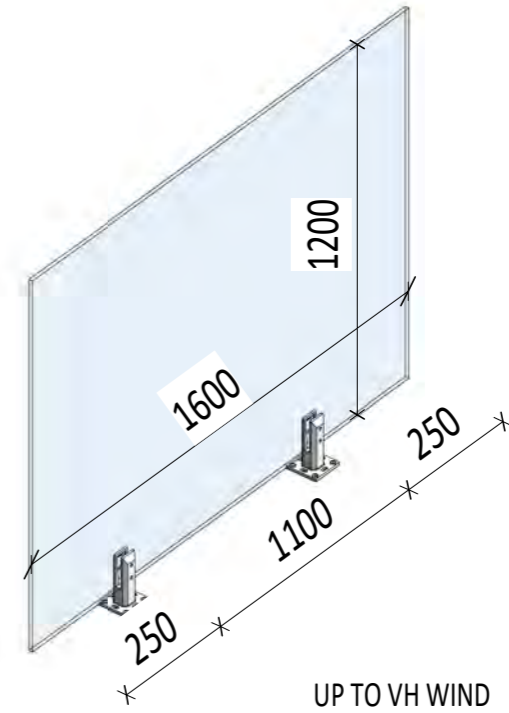
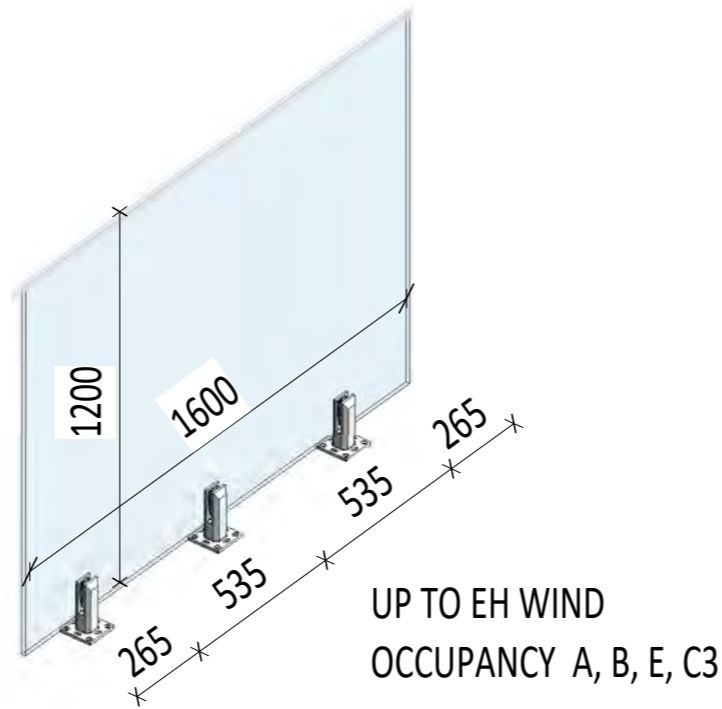
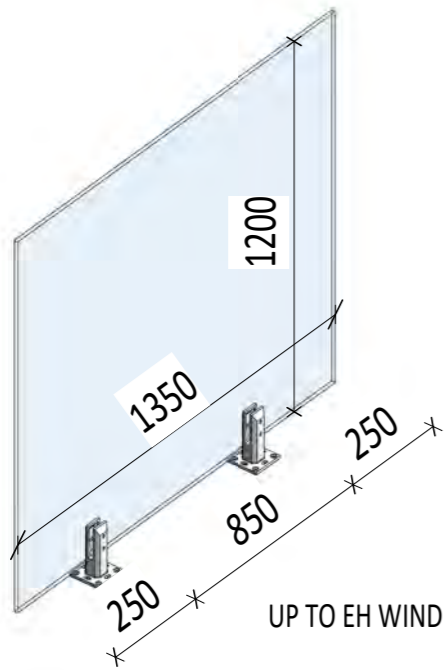

REF.	DESCRIPTION	DATE
R.2	MINOR AMENDMENTS	220525
R.3	FIXING REVISED	220816
R.4	CONCRETE FIXING REVISED	221202
scale: @A3	drawn: AM	checked: PM
	status: P	project no: 20073
	drg no: TF01	rev: R.4

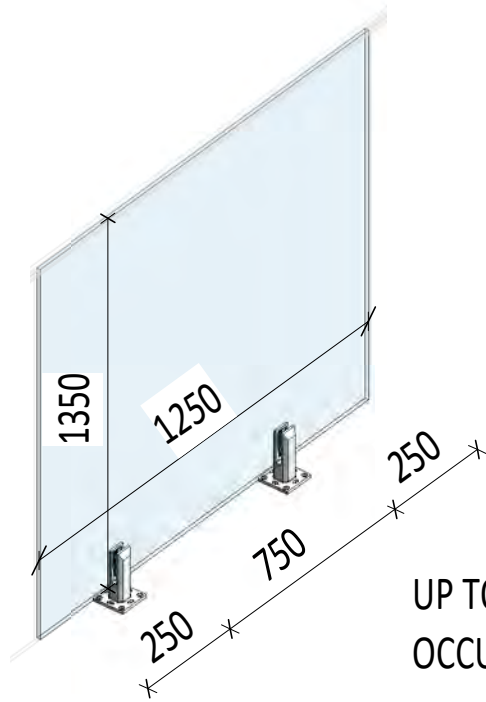

UP TO VH WIND
OCCUPANCY A, B, E, C3

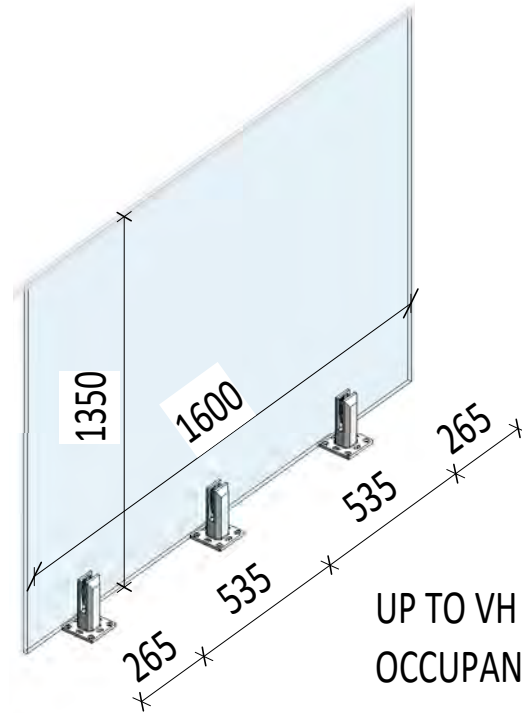

UP TO VH WIND
OCCUPANCY A, B, E, C3

REF.	DESCRIPTION	DATE
R.1	INFORMATION	220328
scale: @A3	drawn: AM	checked: PM
status: P	project no: 21098	drg no: TF02
rev: R.1		

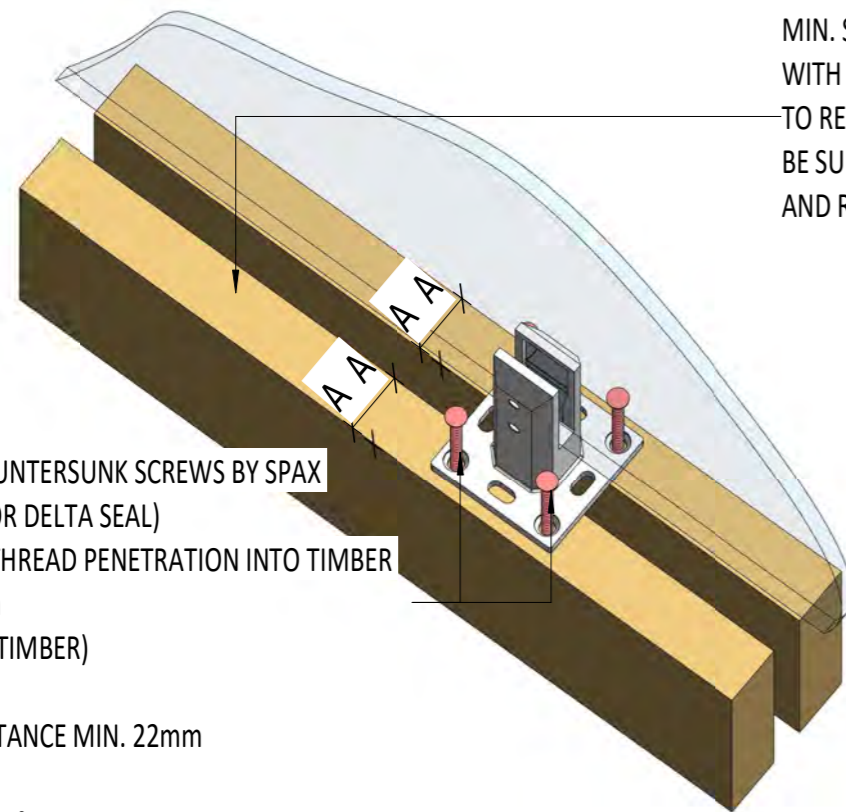

MIN. SG8 TIMBER SUBSTRUCTURE
WITH MEMBERS SUFFICIENTLY SPACED USING A 25MM PACKER BETWEEN JOISTS
TO RECEIVE BOLTS. THE SUBSTRUCTURE DESIGNED BY OTHERS TO
BE SUFFICIENTLY STRONG
AND RIGID TO TRANSFER THE BALUSTRADE LOADS

4/ 8x140 COUNTERSUNK SCREWS BY SPAX
(STAINLESS OR DELTA SEAL)
LENGTH OF THREAD PENETRATION INTO TIMBER
MIN. 130mm
(DRY & WET TIMBER)

A - EDGE DISTANCE MIN. 22mm

Storetech Sku for screw is SCETCSK - 8X140 Spax

CONNECTION TO TIMBER

MECHANICAL ANCHORS:

- 4/HST3-R 8 x 95
STAINLESS STEEL (A4) BY HILTI
MIN. 50mm EMBEDMENT
- OR
- TOGE TSM CSK 8 x 65Min A4
STAINLESS STEEL BY ICCONS,
MIN.65mm INTO CONCRETE
- OR
- 4/W-BS-SK/S 8 x 80
STAINLESS STEEL (A4) BY WURTH,
MIN.60mm INTO CONCRETE

A - EDGE DISTANCE MIN. 55mm
B - CORNER DIST. MIN. 265mm

Storetech Sku - SCECCSA M8x80 Stainless countersunk concrete anchor.

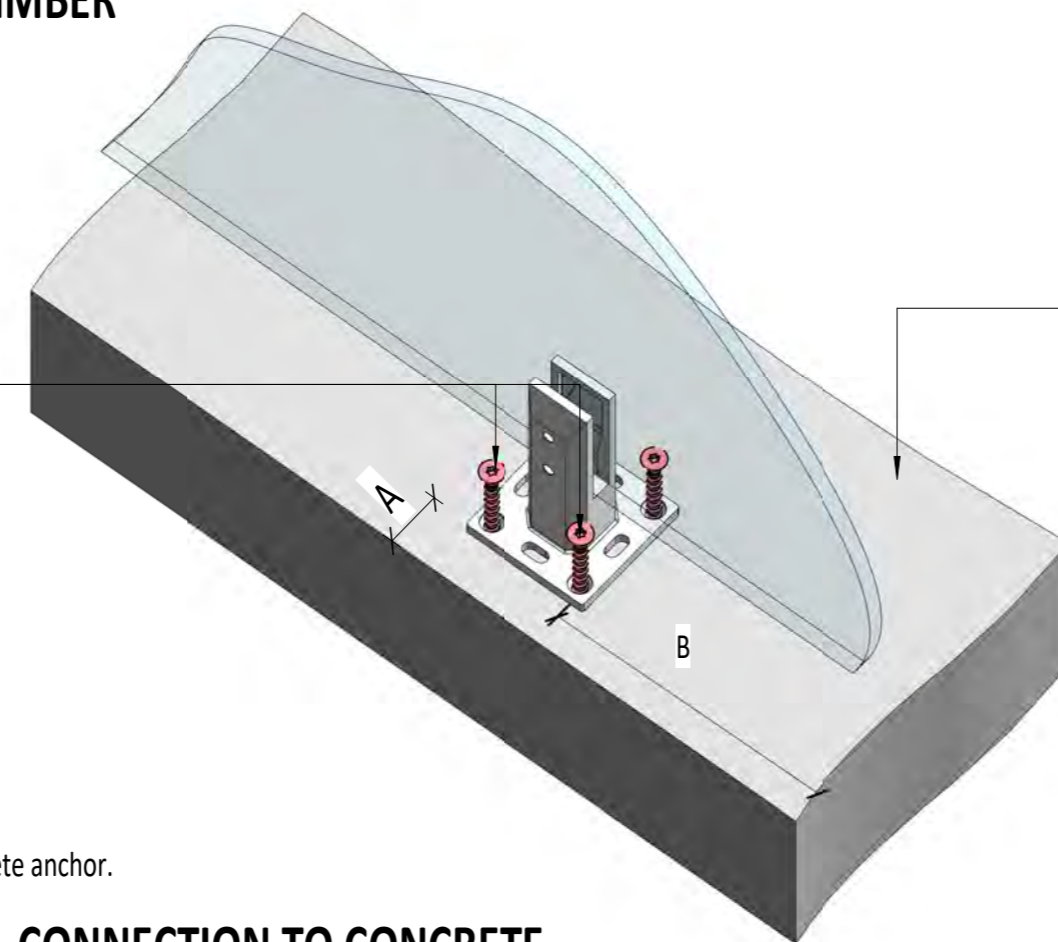

SUFFICIENT STRENGTH AND RIGIDITY
TO SUPPORT THE BALUSTRADE

CONNECTION TO CONCRETE

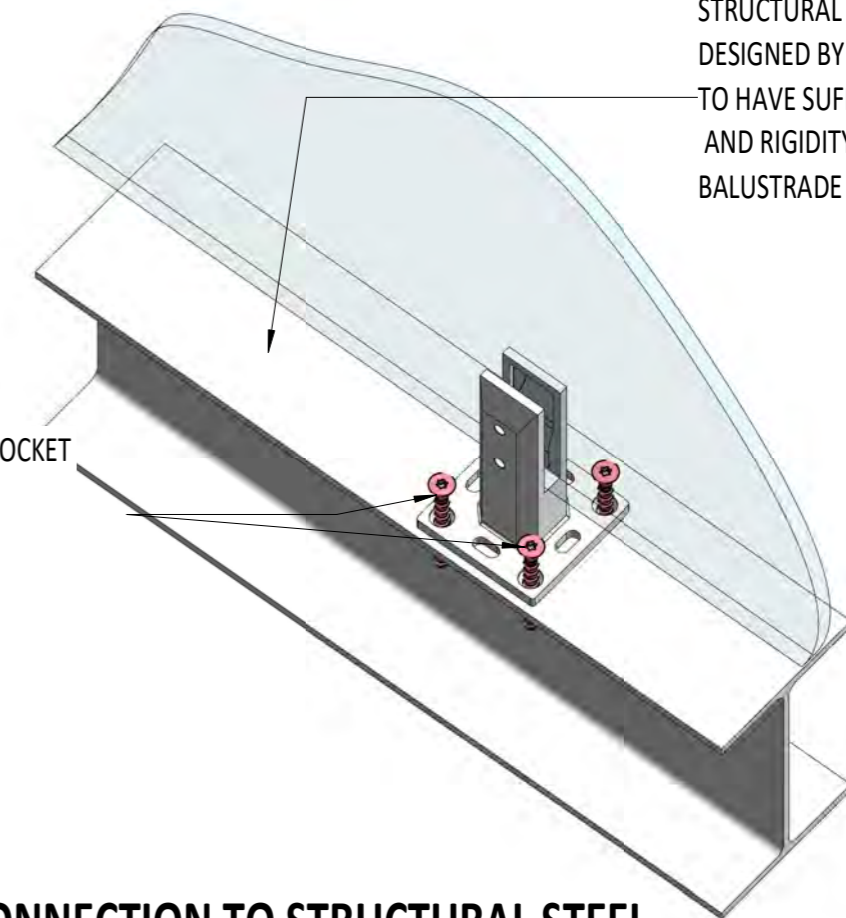

STRUCTURAL STEELWORK
DESIGNED BY OTHERS
TO HAVE SUFFICIENT STRENGTH
AND RIGIDITY TO SUPPORT THE
BALUSTRADE

4/M10 CSK STAINLESS STEEL (A4) SOCKET
SCREWS

A - EDGE DISTANCE MIN. 15mm

CONNECTION TO STRUCTURAL STEEL

IMPORTANT INSTALLATION INSTRUCTIONS:

ALL PROPRIETARY PRODUCTS INCLUDING ANCHORS MUST BE
INSTALLED IN STRICT ORDER WITH MANUFACTURER PROCEDURES.



7 Market Street
Napier. 4110

m. 0210398833, m.0211099712
www.extra-mile.co.nz, info@extra-mile.co.nz

Client:
STORETECH LIMITED

Project:
TEKAPO FIXING SPIGOT

Drawing:
POOL FENCE CONNECTION DETAILS

REF.	DESCRIPTION	DATE
R.2	MINOR AMENDMENTS	220525
R.3	FIXING REVISED	220816
R.4	CONCRETE FIXING REVISED	221202
scale: @A3	drawn: AM	checked: PM
	status: P	project no: 20073
	drg no: TF03	rev: R.4

Section 3 – F2 Compliance

SAFETY GLASS CERTIFICATION F2: COMPLIANCE

STATEMENT OF COMPLIANCE

To satisfy the New Zealand Building Code Acceptable Solution F2/AS1, glass likely to come into contact with people must comply with NZS 4223: Part 3:2016 Code of practice for glazing in buildings – Human impact safety requirements.

NZS 4223: Part 3:2016 requires Grade A safety glass to be used in shower doors, shower screens and bath enclosures and Glass Pool Fencing.

BelAire Designer Fencing confirms glass used in our Glass Pool Fencing and Balustrade has been produced to one or more of the following standards as outlined in NZS:4223:2016: Page Vi

AS/NZS 2208:1996 Grade A

NZS 8500:2006

BS 6206 Grade A

ANSI Z97.1

Peter Carney GENERAL MANAGER

M: 0800 235 2473 | sales@belairefencing.co.nz

Signed: *Peter Carney*

Section 4 – F9 Compliance (Pool Fencing Only)

To satisfy the New Zealand Building Code Acceptable Solution F9, Storetech has a self closing hinge and latch system that has been tested to comply with the New Zealand F9 pool fencing standard.

Completion of the 10,000 Cycle test as shown below

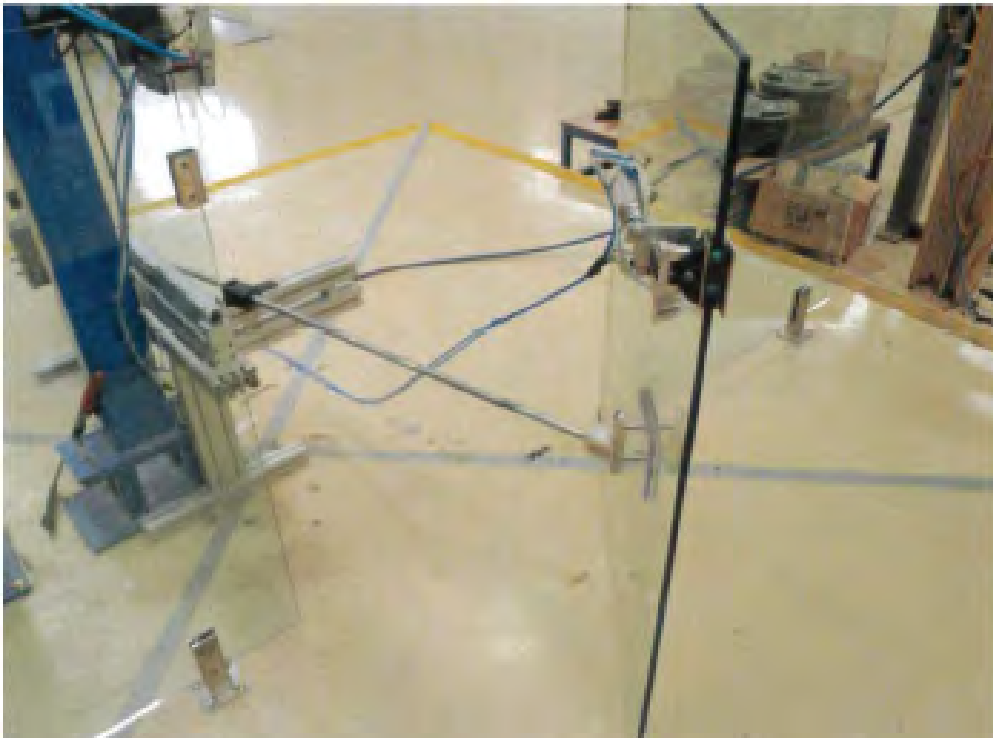

All glass gate hardware has been tested to more than 10,000 cycles. Report available on request.

- Gate Material: 10mm Toughened A grade glass
- Typical Gate Size: 900mm W x 1200mm H
- Lock Description - Magnetic self locking latch
- Lock on inside of the gate: YES
- Self Closing from all angles: YES
- Self Closing from 150mm of Open: YES
- Overall gate height above ground 1260mm
- Polaris self closing soft close hinges tested to 10,000 cycles

Typical Gate Layout to Comply with F9
- Gate Must open away from the pool

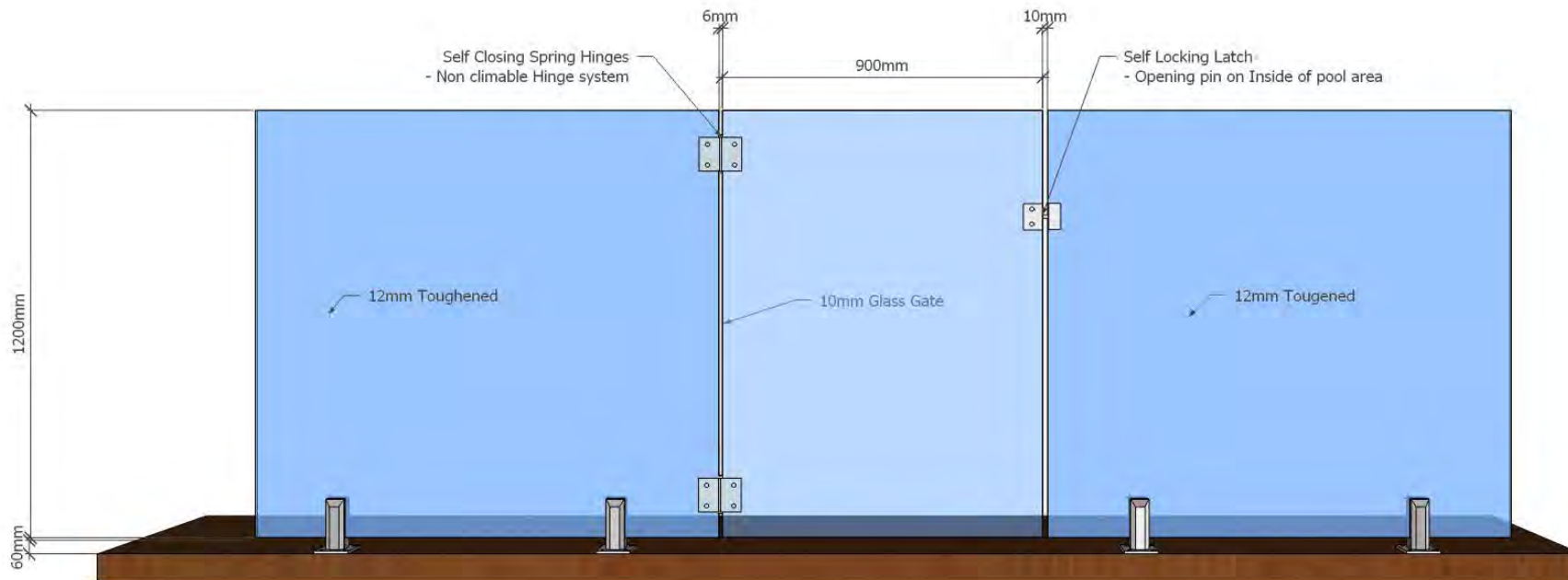

ENGINEERED FRAMELESS GLASS POOL FENCING | GLASS BALUSTRADES | GLASS WIND BREAKS

TEST REPORT



A Z U M A
Design

POOL FENCE



CLIENT – GLASS HARDWARE AUSTRALIA

PRODUCT – POLARIS SOFT CLOSE HINGE 125 SERIES

TESTED BY

AZUMA DESIGN PTY LTD

AZT0350.20

NATA ACCREDITED LABORATORY NO. 15147

This document shall not be reproduced, except in full

Test results in this report are relevant only to the sample tested

The results of the tests, calibrations and/or measurements included in this document are traceable to Australian/national standards

1 Customer Requirements

To test the pool fence sample according to AS1926.1 Set 2012- Swimming Pool Safety Standards Set- Section 3- Loading Requirements. Only the applicable tests for this type of sample shall be carried out.

2 Test Sample Information

2.1 General Information

Product Name/Number	Polaris Soft Close Hinge 125 Series
Customer	Glass Hardware Australia
Address	Unit 6, 4 Stockyard Place, West Gosford NSW 2250
Azuma Test Number	AZT0350.20
Date of Test	24/08/2020 – 03/09/2020
Sample	Supplied and installed by Customer in good condition
Overall Size	1245 mm (Height) x 2720 mm (Width)
Test Sample Description	Glass gate assembly consisting of three panels of glass. Two side fixed glass panels one with a latching bracket and the other with hinge fixings for two hinges. Hinges have soft closing action and the latch has a magnetic strike and bolt.

2.2 Barrier

Material	Toughened Glass	
Overall Dimensions	Hinge Panel	1170 mm (H) x 100 mm (W) x 12 mm (T)
	Latch Panel	1170 mm (H) x 800 mm (W) x 12 mm (T)
Gap between Vertical Elements (< 100 mm)	N/A	
Gap between Horizontal Elements (> 900 mm)	1245 mm	
Total Product Height Greater than 1100 mm	1245 mm	
Gap between bottom of barrier and finished ground level (< 100 mm)	75 mm	

Azuma Design Pty Ltd

38 Redfern Street Wetherill Park, NSW, 2164 Australia +61(02) 9604 0255

Test results in this report are relevant only to the sample tested.

Accreditation Number: 15147 - Accredited for compliance with ISO/IEC 17025 - TESTING.

This document shall not be reproduced, except in full.

AZT 0350.20



2.3 Gate

Material	Toughened Glass
Overall Dimensions	1170 mm (H) x 900 mm (W) x 12 mm
Gap between Vertical Elements (< 100 mm)	10 mm Latch side 8 mm Hinge side
Gap between Horizontal Elements (> 900 mm)	1245 mm
Total Product Height Greater than 1100 mm	1245 mm
Gap between bottom of barrier and finished ground level (< 100 mm)	75 mm

2.4 Spigots (Supplied by Azuma Design)

Material	Duplex 2205 Stainless Steel
Overall Dimensions	50 mm (Width) x 50 mm (Depth) x 160 mm (Height)
Base Plate (if applicable)	100 mm (Width) x 100 mm (Depth) x 8 mm (Thickness)
Drawing Supplied	N/A
Fixing Method	14G x 50 mm Countersunk hex drive screw into timber
Spacing between Posts	220 mm (Left Side) and 700 mm (Right Side)

2.5 Hardware

Latch	Polaris Latch L180P
Hinge	Polaris 125 Series Polaris Soft Close Hinge



Figure 1: Tested Hinge

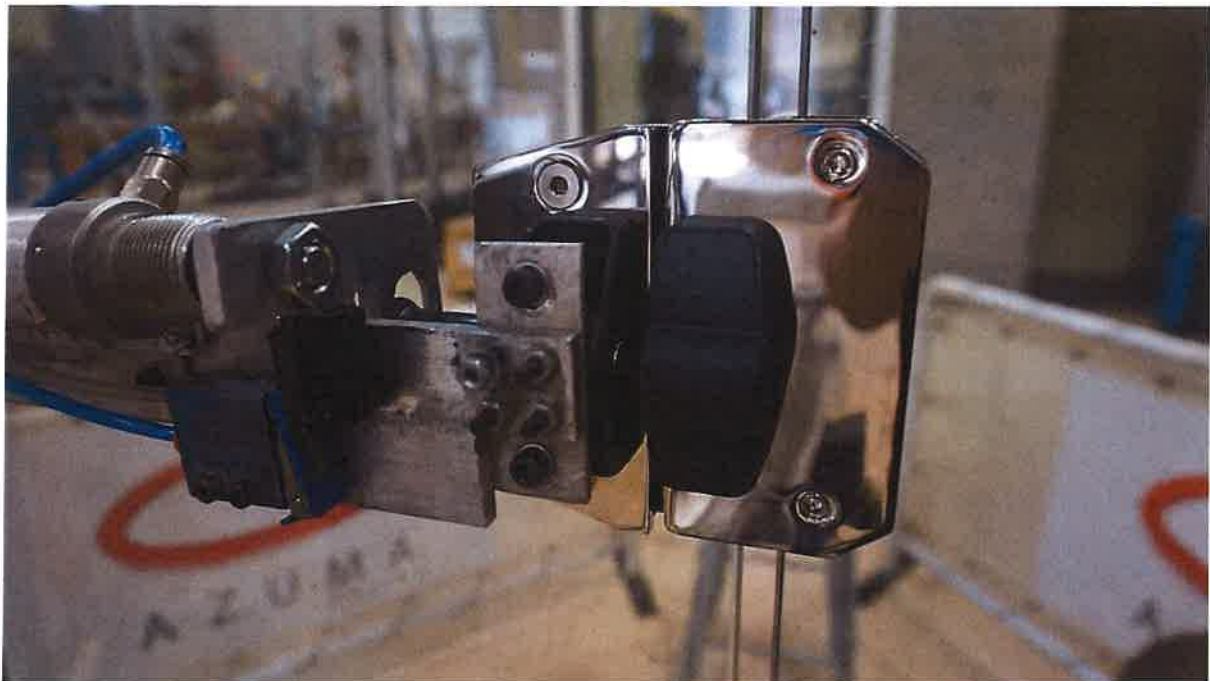

Figure 2: Tested Latch

3 Strength and Rigidity of Barrier Openings

This Test is not applicable to this test sample

4 Strength of Posts and Footings

This Test is not applicable to this test sample

5 Strength of Fencing Components

This Test is not applicable to this test sample

6 Flexible Materials & Components

This Test is not applicable to this test sample

7 Strength Test for Rigid Components of Gate Units

This Test is not applicable to this test sample

8 Durability of Gate Units

8.1 Procedure

From AS 1926.1 - 2012 - Appendix F - Test of Durability of Gate Units.

1. Install the gate unit in accordance with the manufacturer's instructions on a site which simulates the in situ condition with the gate posts securely anchored into the ground.
2. Ensure that the gate and its latch comply with Clause 2.4.
3. Measure and record the force (to the nearest 5 N) required to release the latch.
4. Release the latch and open the gate to the 90-degree position.
5. Release the gate and allow it to close under the action of the self-closing device.
6. Repeat Steps (d) and (e) for a total of 10 000 operations or until the latch fails to operate, whichever occurs first. The latch shall not be lubricated or adjusted during this test.
7. Inspect the gate to see whether it still complies with Clause 2.4.
8. Measure and record the force (to the nearest 5 N) required to release the latch.
9. Inspect the gate, including the hinges and latch together with the gate posts, for any damage which would affect the ability of the gate to comply with the requirements of Section 2.

8.2 Results

Number of Operations the sample completed	25,068 cycles
Does the gate still comply with clause 2.4 after test completed	Yes
The force required to release the latch at the start of the test	10 N
The force required to release the latch at the end of the test	10 N
Any damage to the gate, hinges, latching device or gate posts at the end of the test	Nil
Result	Pass

9 Additional Testing for Gate Units

From AS 1926.1 - 2012 - Section 3.4 - Closing and Latching of Gates.

1. The gate shall close and latch from fully open to resting on the latch, under both of the following conditions:
 - a. Under the natural weight of the gate.
 - b. With the gate open and after a weight of 25 kg has been placed on the top rail or component at a point 100 mm from the outer edge of the locking stile of the gate for 30 seconds and then removed.
2. With the gate closed, the latch and posts of the barrier to which the gate is attached shall be capable of retaining the gate in a closed position when 25 kg is placed at the same location and remains on the gate.

Gate Closes under natural weight	Pass
Gate opened and 25 kg placed 100 mm from locking stile	Pass
Gate closed and 25 kg placed 100 mm from locking stile	Pass
Result	Pass



Figure 3: 25 kg Gate Open

Azuma Design Pty Ltd

38 Redfern Street Wetherill Park, NSW, 2164 Australia +61(02) 9604 0255

Test results in this report are relevant only to the sample tested.

Accreditation Number: 15147 - Accredited for compliance with ISO/IEC 17025 - TESTING.

This document shall not be reproduced, except in full.

AZT 0350.20





Figure 4: 25 kg Gate Closed

10 Conclusion and Signatories

10.1 Conclusion

From the results achieved, it is evident that the sample satisfied the tested requirements as per AS1926.1-2012 Swimming Pool Safety Standards Set.

10.2 Signatories

Tested By: Ash Home

Signature: Ash Home

Date: 01/10/20

END OF REPORT

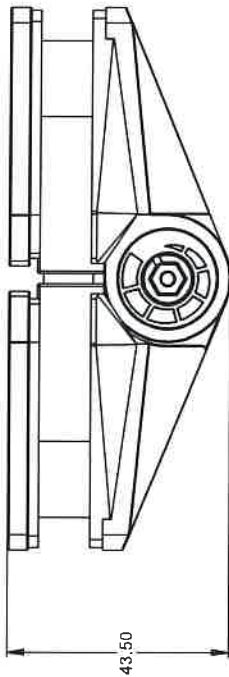
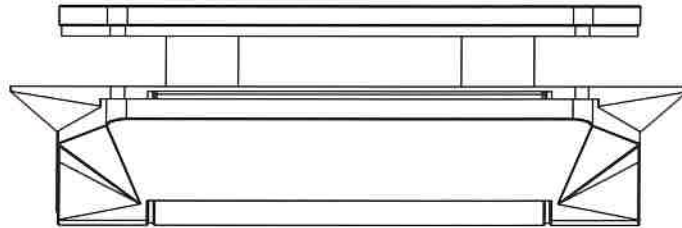
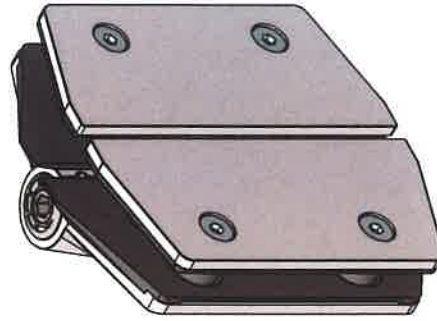
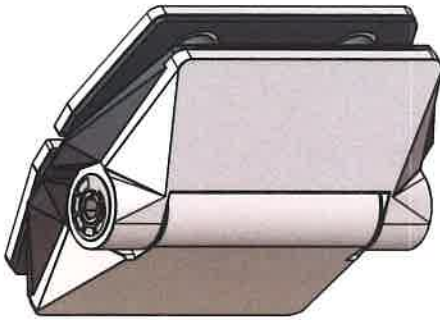

43.50

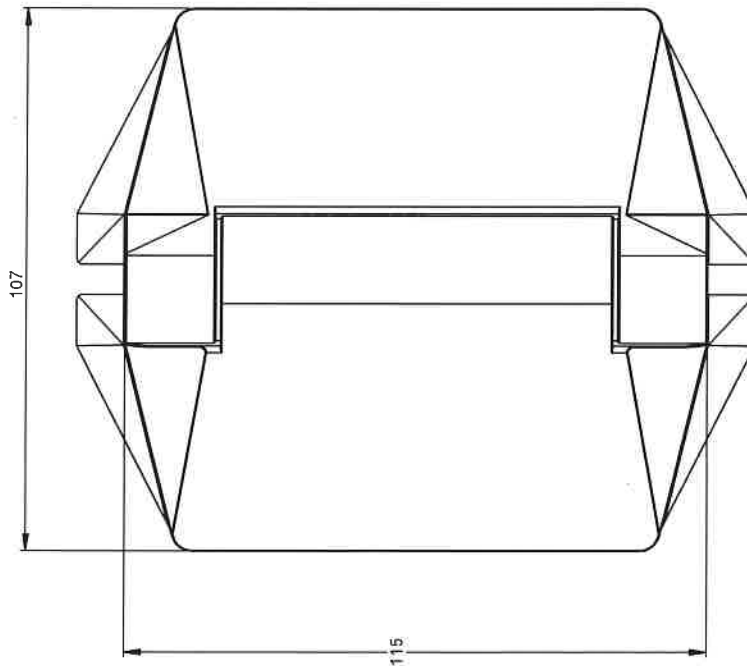

107

115

PROJECT POLARIS 125 HINGE - GG	TITLE 125GG HINGE - GA	
	PART NUMBER 125GG-001	
MATERIAL SEE PARTS		EST. WEIGHT: 1216.20g
FINISH TBA		SHEET SIZE A3
DRAWN BY: CAS		SHEET 1 of 2
DRAWN DATE: 26/05/2020		REV. C
APPROVED BY: .		APPROVED DATE: .
THIS DRAWING AND ANY INFORMATION OR CONTENTS IS THE SOLE PROPERTY OF POLARIS HINGE PTY. LTD. AUSTRALIA. IT MUST NOT BE DISCLOSED, COPIED, LOANED IN WHOLE OR PART OR USED FOR ANY PURPOSE WITHOUT THE PERMISSION OF POLARIS HINGE PTY. LTD.		
PROJECTION METHOD: THIRD ANGLE	DRAWING SCALE: DO NOT SCALE FROM THIS DRAWING	UNLESS OTHERWISE STATED LINEAR TOL: ±0.2mm ANGULAR TOL: 0°5' SURFACE FINISH: 0.8µm DIMENSIONS IN: mm

INFORMATION SUPPLIED BY CUSTOMER

GLASS PREPARATION 120, 220 & 320 SERIES HINGE GLASS TO GLASS

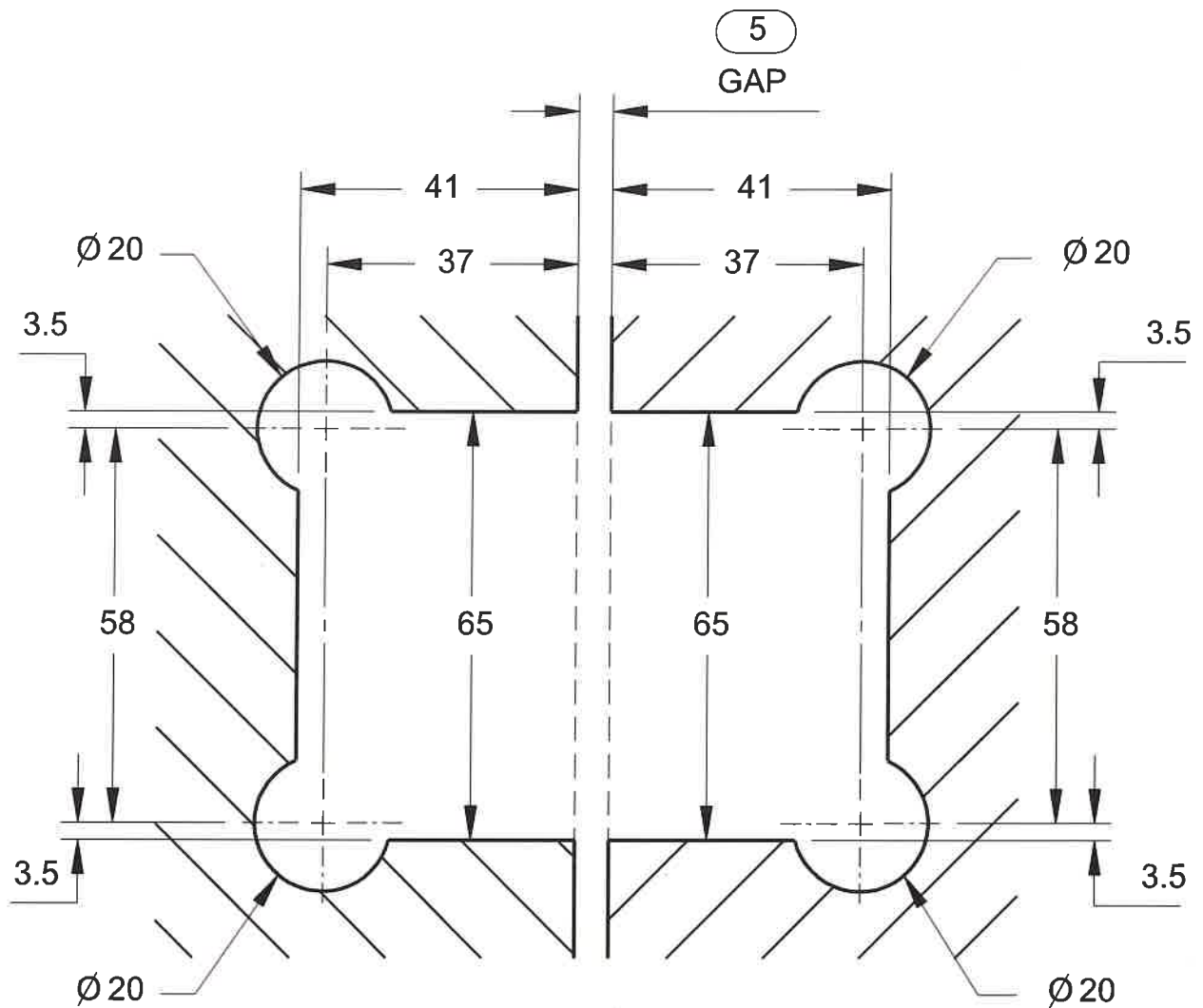

GLASS CUT-OUT TOP AND BOTTOM
[ALL DIMENSIONS IN MILLIMETERS]

LATCH GLASS TO GLASS 180°

TO ORDER SPECIFY:

- **LAGG180P** POLISHED FINISH
 - **LAGG180S** BRUSHED FINISH
 - **LAGG180B** BLACK FINISH
- *MAGNALOCK NOT INCLUDED

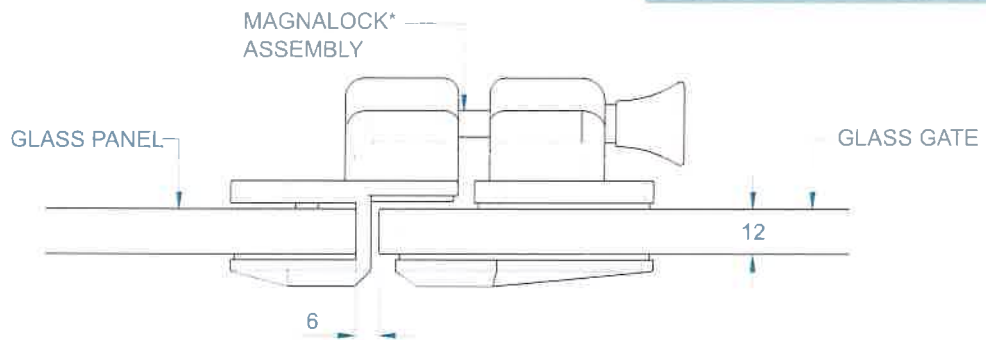

TOP VIEW

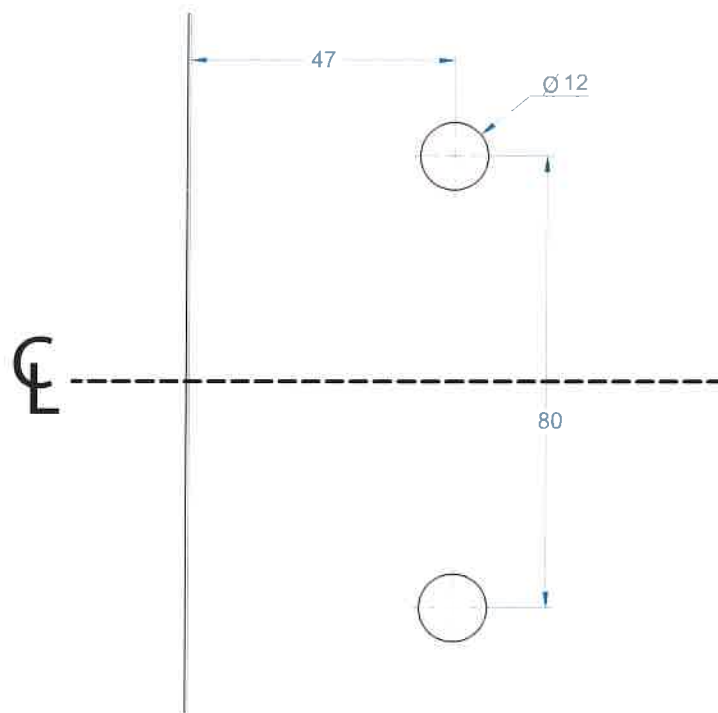

GLASS GATE HOLES

INFORMATION SUPPLIED BY CUSTOMER