



Regulatory information report

KOROK® wall systems installed in scissor stair configurations

Sponsor: KOROK Building Systems NZ Ltd

Report number: FAS200342 Revision: RIR1.1

Issued date: 28 September 2023 Expiry date: 31 August 2028

Quality management

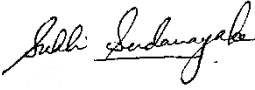
Version	Date	Information about the report	
RIR1.0			Not issued
RIR1.1	Issue: 28 Sep 2023	Reason for issue	Issued in conjunction with R1.1
	Expiry: 31 Aug 2028	Name Signature	Prepared by Ananya Thomas
			Reviewed by Sukhi Sendanayake
			

Executive summary

This report contains the minimum information required for regulatory compliance and refers to the referenced assessment report FAS200342 R1.1.

The analysis conducted in the referenced assessment report documents the findings of the assessment undertaken to determine the expected fire resistance level (FRL) of KOROK® wall systems installed in scissor stair configurations – in accordance with AS 1530.4:2014.

The proposed systems are walls constructed from 78 mm thick, horizontally and/or vertically orientated KOROK® panels installed between two independent stair stringers in scissor stair configurations. KOROK® wall systems are self-supporting non-load bearing walls that may be constructed with either horizontally or vertically stacked panels, or a combination of both. KOROK® panels assessed in this are 78 mm thick lightweight aerated concrete panels which can be described as GEN1 or GEN2 panels with a 0.4 mm BMT galvanised mild steel cover sheathing and 'tongue and groove' detail on their longitudinal edge. The pitch of each panel is 250 mm when installed. The unit weight of a panel can be considered to be nominally 400 kg/m³. All wall systems will consist of perimeter C-tracks at the vertical edges and at the top and bottom edges.

The analysis in sections 5 to 9 of the referenced report found that the proposed systems, together with the described variations, are expected to achieve FRLs as shown in

Contents

1.	Introduction	5
2.	Framework for the assessment	5
2.1	Assessment approach	5
2.2	Compliance with the National Construction Code	6
2.3	Compliance with the New Zealand Building Code (NZBC), Clause C	6
2.4	Declaration	6
3.	Requirements and limitations of the referenced assessment	6
4.	Description of the specimen and variations	8
4.1	Description of assessed systems	8
4.2	Referenced test and assessment data	8
4.3	Variations to the tested systems	9
4.4	Schedule of components	13
5.	Assessment outcome	60
6.	Validity	64

1. Introduction

This report contains the minimum information required for regulatory compliance and refers to the referenced assessment report FAS200342 R1.1.

The analysis conducted in the referenced assessment report documents the findings of the assessment undertaken to determine the expected fire resistance level (FRL) of KOROK® wall systems installed in scissor stair configurations – in accordance with AS 1530.4:2014¹.

The analysis conducted in the referenced assessment report may be used as evidence of suitability in accordance with the requirements of the relevant National Construction Code (NCC) and New Zealand Building Code (NZBC)², Part C, to support the use of the material, product, form of construction or design as given within the scope of the referenced assessment report. It also references test evidence for meeting deemed to satisfy (DTS) provisions of the NCC that apply to the assessed systems.

The referenced assessment was carried out at the request of KOROK Building Systems NZ Ltd. The sponsor details are included in Table 1.

Table 1 Sponsor details

Sponsor	Address
KOROK Building Systems NZ Ltd	22 Norris Avenue Hamilton 3200 New Zealand

2. Framework for the assessment

2.1 Assessment approach

An assessment is a professional opinion about the expected performance of a component or element of structure subjected to a fire test.

No specific framework, methodology, standard or guidance documents exists in Australia for undertaking these assessments. We have therefore followed the ‘Guide to undertaking technical assessments of the fire performance of construction products based on fire test evidence’ prepared by the Passive Fire Protection Forum (PFPF) in the UK in 2021³.

This guide provides a framework for undertaking assessments in the absence of specific fire test results. Some areas where assessments may be offered are:

- Where a modification is made to a construction which has already been tested
- The interpolation or extrapolation of results of a series of fire resistance tests, or utilisation of a series of fire test results to evaluate a range of variables in a construction design or a product
- Where, for various reasons – eg size or configuration – it is not possible to subject a construction or a product to a fire test.

Assessments can vary from relatively simple judgements on small changes to a product or construction through to detailed and often complex engineering assessments of large or sophisticated constructions.

The referenced assessment uses established empirical methods and our experience of fire testing similar products to extend the scope of application by determining the limits for the design and performance based on the tested constructions and performances obtained. The assessment is an

¹ Standards Australia, 2014, Methods for fire tests on building materials, components and structures – Part 4: Fire-resistance tests for elements of construction, AS 1530.4:2014, Standards Australia, NSW.

² New Zealand Building Code - Building Regulations 1992 including Amendments, Ministry of Business, Innovation, and Employment, New Zealand

³ Passive Fire Protection Forum (PFPF), 2021, Guide to undertaking technical assessments of the fire performance of construction products based on fire test evidence, Passive Fire Protection Forum (PFPF), UK.

evaluation of the potential fire resistance performance of the elements in accordance with AS 1530.4:2014.

The referenced assessment has been written in accordance with the general principles outlined in EN 15725:2010⁴ for extended application reports on the fire performance of construction products and building elements.

The referenced assessment has been written using appropriate test evidence generated at accredited laboratories to the relevant test standard. The supporting test evidence has been deemed appropriate to support the manufacturer's stated design.

2.2 Compliance with the National Construction Code

The referenced assessment report has been prepared to meet the evidence of suitability requirements of the NCC 2022⁵ under A5G3 (1) (d). It references test evidence for meeting deemed to satisfy (DTS) provisions of the NCC under A5G5 for fire resistance level that apply to the assessed systems based on Specifications 1 and 2 for fire resistance for building elements.

The referenced assessment report may also be used to demonstrate compliance with the requirements for evidence of suitability under the relevant sections of previous versions of the NCC.

2.3 Compliance with the New Zealand Building Code (NZBC), Clause C

The referenced assessment report has been prepared to meet the evidence of suitability requirements for the relevant clauses of the New Zealand Building Code (NZBC), Part C. The referenced assessment references test evidence for meeting a performance requirement for a fire resistance rating as applicable to the assessed systems.

The referenced assessment report may also be used to demonstrate compliance with the requirements for evidence of suitability that meets the normative requirements for demonstrating fire resistance performance as stated in the New Zealand acceptable solutions.

2.4 Declaration

The 'Guide to undertaking technical assessments of the fire performance of construction products based on fire test evidence' prepared by the PFPPF in the UK requires a declaration from the client. By accepting our fee proposal on 15 March 2022, KOROK Building Systems NZ Ltd confirmed that:

- To their knowledge, the variations to the component or element of structure, which is the subject of the referenced assessment, have not been subjected to a fire test to the standard against which the referenced assessment is being made.
- They agree to withdraw the referenced assessment from circulation if the component or element of structure is the subject of a fire test by a test authority in accordance with the standard against which the referenced assessment is being made and the results are not in agreement with the referenced assessment.
- They are not aware of any information that could adversely affect the conclusions of the referenced assessment and – if they subsequently become aware of any such information – they agree to ask the assessing authority to withdraw the assessment.

3. Requirements and limitations of the referenced assessment

- The scope of the referenced assessment report is limited to an assessment of the variations to the tested systems described in section 4.3.
- The referenced assessment report details the methods of construction, test conditions and assessed results expected in accordance with AS 1530.4:2014.

⁴ European Committee for Standardization, 2010, Extended application reports on the fire performance of construction products and building elements, EN 15725:2010, European Committee for Standardization, Brussels, Belgium

⁵ National Construction Code Volumes One and Two - Building Code of Australia 2022, Australian Building Codes Board, Australia

- The results of the referenced assessment are applicable to the assessed horizontally or vertically orientated KOROK® wall systems with fire exposure from either side.
- It is a requirement that the structural steel and concrete members are designed appropriately by a professional structural engineer by considering all the possible design actions. Design of structural steel and concrete members is not a part of the scope of the referenced assessment.
- It is required that the lateral load capacity of the perimeter tracks be verified by a professional structural engineer for the lateral load capacity under ambient loading conditions.
- It is required that the support construction above and below the wall be capable of providing adequate vertical and lateral support for at least 120 minutes.
- The actual structural strength of the stairs and the surrounding walls, which may not be KOROK® walls, and their ability to handle the design loads must be validated by a professional structural engineer engaged by others or by the relevant building project construction managers and are not part of the referenced assessment.
- It is required that the supporting structure, including the perimeter tracks, are of the same or greater fire rating than that of the KOROK® wall systems.
- Handrail loads have not been considered in the structural calculations performed by Warringtonfire for the purposes of the referenced assessment. Therefore, if hand rails are to be fixed to the wall systems, the inclusion of handrails must be designed by a professional structural engineer considering the additional loads.
- For all KOROK® wall heights, the supporting structural steel components must be designed accordingly by a professional structural engineer and fire protection of the steel components must be carried out.
- The capacity of the Hilti HUS3-H bolts under fire exposure must be obtained from the Hilti technical data sheet and must be designed by a professional engineer considering all applied loads. The minimum edge and spacing distances must be obtained from the technical data sheets or be designed by a professional engineer, considering factors such as conditions of fire exposure.
- The screw connections between the stair stringer angle and the concrete stair stringer are not part of the scope of the referenced assessment and must be designed by a professional engineer, considering all design loads.
- Those variations which rely on assessment reports and other supplementary reports listed in section 4.2 are only positively assessed provided that the referenced reports are valid and therefore the referenced assessment must be read in conjunction with those reports.
- The referenced assessment has been prepared based on the fire performance and condition of the products/systems at the time they were tested. Any deterioration of fire performance due to external factors, including but not limited to passage of time and exposure to elements, is not considered in the referenced assessment report.
- The referenced assessment report is only valid for the assessed systems and must not be used for any other purpose. Any changes with respect to size, construction details, loads, stresses, edge or end conditions – other than those identified in the referenced assessment report – may invalidate the findings of the referenced assessment. If there are changes to the system, a reassessment will need to be done by an Accredited Testing Laboratory (ATL) that is accredited to the same nominated standards as the referenced assessment report.
- The referenced assessment report has been prepared using on information provided by others. Warringtonfire has not verified the accuracy and/or completeness of that information and will not be responsible for any errors or omissions that may have been incorporated into the referenced assessment report as a result.
- The referenced assessment is based on the proposed systems being constructed under comprehensive quality control practices and following appropriate industry regulations and Australian Standards on quality of materials, design of structures, guidance on workmanship and expert handling, placing and finishing of the products on site. These variables are beyond the control and consideration of the referenced assessment report.

4. Description of the specimen and variations

4.1 Description of assessed systems

The proposed systems are walls constructed from 78 mm thick, horizontally and/or vertically orientated KOROK® panels used for fire separation between two independent stair stringers in scissor stair configurations.

KOROK® wall systems are self-supporting non-load bearing walls that may be constructed with either horizontally or vertically stacked panels or a combination of both. KOROK® panels assessed in this are 78 mm thick lightweight aerated concrete panels that can be described as GEN1 or GEN2 panels with a 0.4 mm BMT galvanised mild steel cover sheathing and 'tongue and groove' detail on their longitudinal edge. The pitch of each panel is 250 mm when installed. The unit weight of a panel can be considered as nominally 400 kg/m³. All wall systems will consist of perimeter C-tracks at the vertical edges and at the top and bottom edges.

Single 78 mm thick horizontally and/or vertically orientated walls have been tested as provided in Appendix B of the referenced report, and it is proposed to extend their fire resistance performance to variations of horizontally and vertically orientated single and dual-stacked wall systems denoted as WT1A, WT1B, WT2, WT2A, WT3A, WT3B and WT3C.

4.2 Referenced test and assessment data

The assessment of the variation to the tested systems and the determination of the expected performance are based on the results of the fire tests documented in the reports summarised in Table 2 and the assessment reports detailed in Table 3. Other referenced supplementary data was obtained from the report listed in Table 4. Further details of the tested systems are included in Appendix B of the referenced report. All sponsors have provided permission for their reports to be referenced in the assessment.

Table 2 Referenced test data

Report number	Test sponsor	Test date	Testing authority
WARRES 69754/C	Hilti Ag	14 November 1996	Warrington Fire Research
FR3754 (Issue 2)	KOROK Building Systems NZ Limited	17 May 2006	BRANZ
WF 376610B	Sika Services AG	3 August 2017	Exova Warringtonfire
EWFA 53390600.1	Hilti Aust Pty Ltd	19 July 2018	Exova Warringtonfire
FR10618-001 Issue 2	KOROK Building Systems NZ Limited	30 May 2019	BRANZ
FR11543-002	KOROK Building Systems NZ Limited	2 July 2019	BRANZ

Table 3 Referenced assessment data

Report number	Sponsor	Issued date	Issuing authority
40962700 R2.0	Promat Australia Pty Ltd	26 February 2021	Warringtonfire
45752 R3.1	Promat Australia Pty Ltd	10 August 2023	Warringtonfire

Table 4 Other referenced supplementary data

Report number	Sponsor	Issued date	Issuing authority
J200085 Issue 02	KOROK Building Systems NZ Limited	17 May 2021	Oculus Architectural Engineering Limited

4.3 Variations to the tested systems

The tested systems and variations to those tested systems – together with the referenced standard fire tests – are described in Table 5.

Table 5 Variations to tested systems

Wall type	Reference tests	Description of tests	Variations
WT2	FR11543-002 FR10618-001 FR3754 (Issue 2)	<p>In test FR11543-002, a 3 m × 3 wall with 78 mm thick vertically orientated panels was tested. A load of 4.53 kN per linear metre was applied as a uniformly distributed axial load to the wall 15 minutes before the start of the test. After a test duration of 245 minutes, the applied load was increased to 5.77 kN per linear metre and maintained for the remaining 5 minutes.</p> <p>Test FR10618-001 consisted of a 3 m × 3 wall with 78 mm thick horizontally orientated KOROK® panels. On the unexposed face of the wall, a 120 kg/m dead load was attached to the wall nominally 300 mm right of mid-width which extended over the full height of the wall. A further 57 kg deadload was added after a duration of 125 minutes and remained in place for the 245-minute test duration.</p> <p>The horizontal panels were fixed to 80 mm wide × 60 mm high × 1.15 mm BMT C-tracks capping the perimeter of the wall. On the unexposed face of the wall, the panels were fixed to the left side vertical C-track using 30 mm × 10 g self-tapping steel screws at 250 mm centres at the panel joint positions. At the head and base, the panels were fixed to both horizontal C-tracks from the left side to mid-width using 16 mm × 10 g self-tapping steel screws at 400 mm centres. The KOROK® panels joints were fixed in one row, 1000 mm from the left side with 16 mm × 10 g self-tapping steel screws at each panel joint. The fixing pattern was mirrored on the exposed face.</p> <p>In FR3754 (Issue 2), the test specimen consisted of a non-load bearing 78 mm thick KOROK® wall where the panels were orientated vertically to form a 3000 mm (wide) × 3000 mm (high) wall. The panels were joined</p>	<ul style="list-style-type: none"> • Single wall consisting of horizontally orientated KOROK® panels connected to C-tracks on the vertical edges. • For a proposed FRL of -/60/60 – the maximum horizontal span is 5.5 m and the slab-to-slab height is maximum 4 m with 1.15 mm BMT side C-tracks. • For a proposed FRL of -/120/120 – the maximum horizontal span is 5 m and the slab-to-slab height is maximum 4 m with 1.45 mm BMT side C-tracks. • C-tracks are fixed at the top and bottom to concrete landings with M14 or 2 × M10 anchors at each landing. • Wall is connected to the steel angle beneath the concrete stair stringers (1.45 mm BMT) on both sides with 10g screws at maximum 500 mm c/c spacing horizontally. • The wall system consists of a mid-landing which is discontinuous between the scissor stairs or the wall system may not have a mid-landing. • Reference Figure 2 and Figure 5.
WT2A			<ul style="list-style-type: none"> • Same as WT2 but with the mid-landing continuous between the two opposite scissor stairs. • Reference Figure 3 and Figure 6.
WT2C			<ul style="list-style-type: none"> • Dual-stack wall system consisting of two wall segments made of horizontally orientated KOROK® panels. • The horizontally orientated wall sections are connected via back-to-back C-tracks. The connection point between back-to-back C-tracks must be protected with a 0.7 mm BMT galvanised steel flashing on the unexposed side. • For a proposed FRL of -/60/60 – the maximum horizontal span of each wall is 5.5 m and the slab-to-slab height is maximum 4 m with 1.15 mm BMT side C-tracks.

Wall type	Reference tests	Description of tests	Variations
		using a tongue and groove installation method and screw fixed in a row at the panel interlocking joints. The panels were constructed of a galvanized steel skin, nominally 0.4 mm BMT thick, encasing an aerated concrete core. The weight of the panel was measured to be 4.6 kg for a 0.4 m length of panel. The perimeter of the wall consisted of galvanized steel angles (64 mm × 55 mm × 1.15 mm thick) bolted at 500 mm centres to the top, bottom and left side of the frame using Hilti DB7 fasteners.	<ul style="list-style-type: none"> For a proposed FRL of -/120/120 – the maximum horizontal span of each wall is 5 m and the slab-to-slab height is maximum 4 m with 1.45 mm BMT side C-tracks. C-tracks are fixed at the top and bottom to concrete landings with M14 or 2 × M10 anchors at each landing, including mid-landings. Wall is connected to the steel angle beneath the concrete stair stringers (1.45 mm BMT) on both sides with 10g screws at maximum 500 mm c/c spacing horizontally. Consists of a mid-landing which is discontinuous between the scissor stairs or short and long leg support brackets are used instead of a mid-landing, where required. Reference Figure 7.
WT2D			<ul style="list-style-type: none"> Same as WT2C but with the mid-landing continuous between the two opposite scissor stairs. Reference Figure 8.
WT3A			<ul style="list-style-type: none"> Same as WT3C and WT3B except that a fire protected structural steel or concrete beam is installed to support the topmost level only. Reference Figure 9.
WT3B			<ul style="list-style-type: none"> Same as WT3C but with the mid-landing continuous between the two opposite scissor stairs. The horizontal span (X) and maximum total wall height (Y_{max}) can be unlimited provided that each panel extends up to a maximum height of 4 m between back-to-back tracks and is connected to the stair stringer angle (1.45 mm BMT) with minimum one 10 g screw on each side of the wall (therefore minimum two screws per panel). The maximum spacing between 10 g stair stringer angle screws to be 250 mm. At the continuous mid-landing, the self-weight of the vertical panels must be supported by the mid-landing. Reference Figure 10.
WT3C			<ul style="list-style-type: none"> Single wall consisting of vertically orientated KOROK® panels connected to C-tracks on the vertical edges supported by the connection to the bottom steel angle of the stair stringers. Each wall segment is divided by horizontal back-to-back C-tracks which are not expected to transfer any loads or provide any structural

Wall type	Reference tests	Description of tests	Variations
			<p>stiffness. The connection point between back-to-back C-tracks must be protected with a 0.7 mm BMT galvanised steel flashing on the unexposed side.</p> <ul style="list-style-type: none"> The horizontal span (X) and maximum total wall height (Y_{max}) can be unlimited provided that each panel extends up to a maximum height of 4 m between back-to-back tracks and is connected to the stair stringer angle (1.45 mm BMT) with minimum one 10 g screw on each side of the wall (therefore minimum two screws per panel). The maximum spacing between 10 g stair stringer angle screws to be 250 mm. Reference Figure 11.
WT1A			<ul style="list-style-type: none"> Dual-stack wall system consisting of a wall segment made of vertically orientated KOROK® panels between two wall segments with horizontally orientated KOROK® panels. The horizontal and vertical orientated wall sections are connected via back-to-back C-tracks. The connection point between back-to-back C-tracks must be protected with a 0.7 mm BMT galvanised steel flashing on the unexposed side. The vertical wall – at mid-width of the dual-stack wall system – is supported by the stair stringer angle at the mid-landing or by KOROK® support brackets. For a proposed FRL of -/60/60 – the maximum horizontal span of each horizontal wall segment is 5.5 m. The slab-to-slab height is maximum 4 m with 1.15 mm BMT side C-tracks. For a proposed FRL of -/120/120 – the maximum horizontal span of each horizontal wall segment is 5 m. The slab-to-slab height is maximum 4 m with 1.45 mm BMT side C-tracks. The minimum horizontal width of the vertical wall segment must be 500 mm (two panels orientated vertically). Each panel can extend up to a maximum height of 4 m between back-to-back tracks and must be connected to the stair stringer angle (1.45 mm BMT) with minimum one 10 g screw on each side of the wall (therefore minimum two screws per panel). The maximum spacing between 10 g stair stringer angle screws to be 250 mm. Reference Figure 12.
WT1B			<ul style="list-style-type: none"> Same as WT1A but with the mid-landing continuous between the two opposite scissor stairs.

Wall type	Reference tests	Description of tests	Variations
			<ul style="list-style-type: none"> At the continuous mid-landing, the self-weight of the vertical panels must be supported by the mid-landing. Reference Figure 13.
All walls	WF 376610B EWFA 53390600.1 40962700 R2.0 45752 R3.1	<p>In test WF 376610B, the section of floor tested was 2240 mm long × 1730 mm wide × 150 mm thick and was made of autoclaved aerated concrete (AAC) lintels. Specimen K consisted of a 40 mm wide linear gap filled with 32 mm depth of Sikaflex® 400 polyurethane sealant installed flush on the unexposed face of the floor. The seals were backed with 50 mm diameter closed cell polyethylene backing rod. Specimen L consisted of a 12 mm wide linear gap filled with 9.6 mm depth of Sikaflex® 400 polyurethane sealant installed flush on the unexposed face of the floor. The seals were backed with 15 mm diameter closed cell polyethylene backing rod.</p> <p>In test EWFA 53390600.1, the test specimen consisted of two 200 mm wide control joints protected by mineral wool (minimal density 60 kg/m³, compressed 33%) and Hilti Firestop joint sprays on the unexposed side.</p> <p>Assessment report 40962700 R2.0 documents the findings of the assessment undertaken to determine the likely fire resistance level (FRL) of PROMASEAL® FyreStrip systems protecting joints in walls and floors made of masonry and concrete – if tested in accordance with AS 1530.4:2014 and assessed in accordance with AS 4072.1:2005.</p> <p>Assessment report 45752 R3.1 addresses various control joints and metal pipe penetrations through concrete wall and floor elements. These systems are protected with PROMASEAL® IBS™ foam strips used in conjunction with either non-fire rated silicone sealant or fire rated acrylic sealant.</p>	<ul style="list-style-type: none"> The fire resistance performance of the proposed KOROK® walls in the vertical plane is provided at the wall-to-stair stringer joint at the boundaries of the KOROK® wall section highlighted in Figure 4. The wall-to-stair stringer joint detail varies based on the width of the joint between the KOROK® wall and the concrete stairs. The various joint configurations are shown in Figure 24 to Figure 30.

4.4 Schedule of components

Table 6 outlines the schedule of components for the assessed systems.

Table 6 Schedule of components of assessed systems

Item	Description	
Wall components		
1.	Name	GEN1 or GEN2 KOROK® panel
	Material	Mild steel section filled with aerated lightweight concrete with nominal density 400 kg/m ³ . The cover sheathing is minimum 0.4 mm BMT galvanised steel.
	Dimensions	250 mm (pitch) × 78 mm (thickness)
2.	Name	C-track with equal or better sectional bending and compression capacity
	Material	Galvanised mild steel (minimum f_y at ambient temperatures = 250 MPa)
	Dimensions	<ul style="list-style-type: none"> 60 mm × 80 mm × 1.15 mm BMT for an FRL of -/60/60 60 mm × 80 mm × 1.45 mm BMT for an FRL of -/120/120
3.	Name	Steel angle for stair stringer
	Material	Galvanised mild steel (minimum f_y at ambient temperatures = 250 MPa)
	Dimensions	Minimum 1.45 mm BMT thickness. Width and length varied to suit the width of the wall-to-stair gap.
4.	Name	Landings and stair stringer
	Material	Concrete (minimum compressive strength of 32 MPa)
	Dimensions	Minimum 120 mm thick and designed by a professional engineer in accordance with AS 3600:2018 for an established FRL of 60/60/60 or 120/120/120 as required.
5.	Name	Metal flashing (junction protection)
	Material	Minimum 0.7 mm thick galvanised mild steel
	Installation	Fixed to at least one face over junctions.
6.	Name	KOROK® short and long leg support brackets
	Material	Galvanised mild steel (minimum f_y at ambient temperatures = 250 MPa)
	Installation	Installed on both sides of the wall connecting the stair stringer to the wall. Width and length varied to suit the width of the wall-to-stair gap. These brackets must therefore be designed accordingly by a professional engineer considering all imposed design actions to maintain structural adequacy of the KOROK® walls assuming that only one bracket will retain its ambient strength capacity to support all applied loads.
Fire sealing systems		
7.	Material	Hilti CFS-SP SIL silicone sealant
	Installation	2 mm wet film thickness and overlapping surrounding separating element by minimum 15 mm installed on the unexposed face of the joint.
8.	Material	Hilti CFS-SP WB acrylic sealant
	Installation	3 mm wet film thickness and overlapping surrounding separating element by minimum 15 mm installed on the unexposed face of the joint.
9.	Material	Mineral wool batt
	Installation	100 mm thick each layer with nominal density of 60 kg/m ³ and compressed 33% installed vertically into the joint.
10.	Material	Sikaflex® 400
	Installation	Installed in a sealant width-to-depth ratio of 1:1 on the unexposed face of the joint.

Item	Description	
11.	Material	Sika PEF backing rods
	Installation	Diameters to suit the gap width to be installed below Sikaflex® 400 layer.
12.	Material	PROMASEAL® Fyrestrip
	Dimensions	Refer to assessment report 40962700 R2.0
13.	Material	PROMASEAL® IBS strips
	Dimensions	Refer to Table 7 and assessment report 45752 R3.1
Fixings		
14.	Name	Anchoring C-tracks into concrete landings
	Dimensions	1 × M14 or 2 × M10 Hilti HUS3-H anchors: <ul style="list-style-type: none"> • For M14 – minimum 65 mm embedment length in concrete • For M10 – minimum 55 mm embedment length in concrete
15.	Name	Fixings connecting C-tracks to continuous mid-landings (where load transfer is not required)
	Dimensions	M6.5 × 32 mm Mushroom head spikes at 400 mm c/c
16.	Name	Fixings connecting back-to-back C-tracks
	Dimensions	10g tek screws staggered at 250 mm c/c
17.	Name	Fixings connecting KOROK® panels to C-tracks on vertical edge
	Dimensions	10g × 30 mm tek wafer head screws into every panel joint at 250 mm c/c on both exposed and unexposed sides
18.	Name	Fixings connecting KOROK® panels to steel stair stringer angle
	Dimensions	<ul style="list-style-type: none"> • 10g × 30 mm tek wafer head screws into every panel joint at 500 mm c/c horizontally in horizontally orientated walls – on both sides of the wall • 10g × 30 mm tek wafer head screws into every panel joint at 250 mm c/c horizontally in horizontally orientated walls – on both sides of the wall

Assessed wall configurations are shown in Figure 1 to Figure 46.

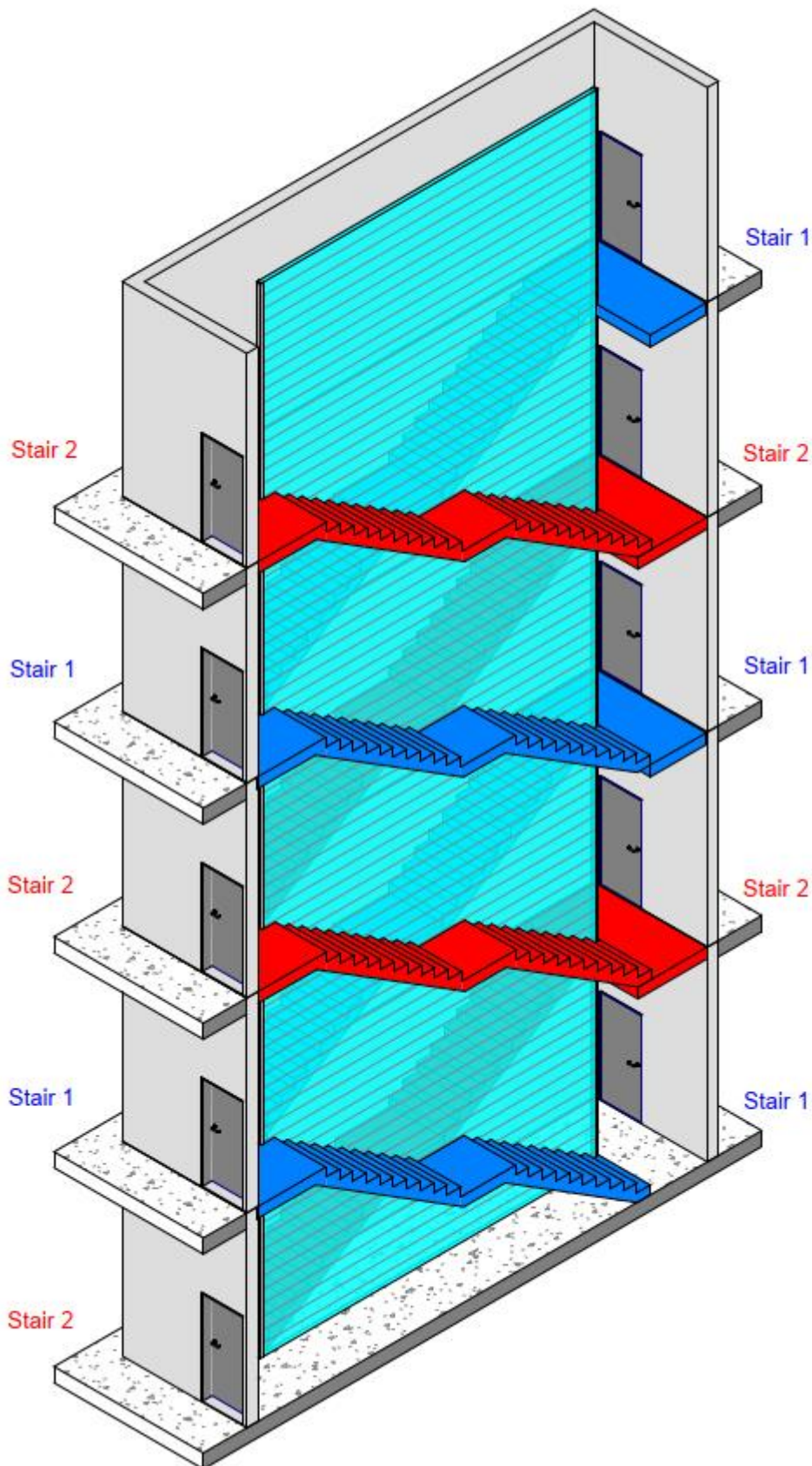

Figure 1 Scissor stair configuration – two staircases separated by a central KOROK® wall

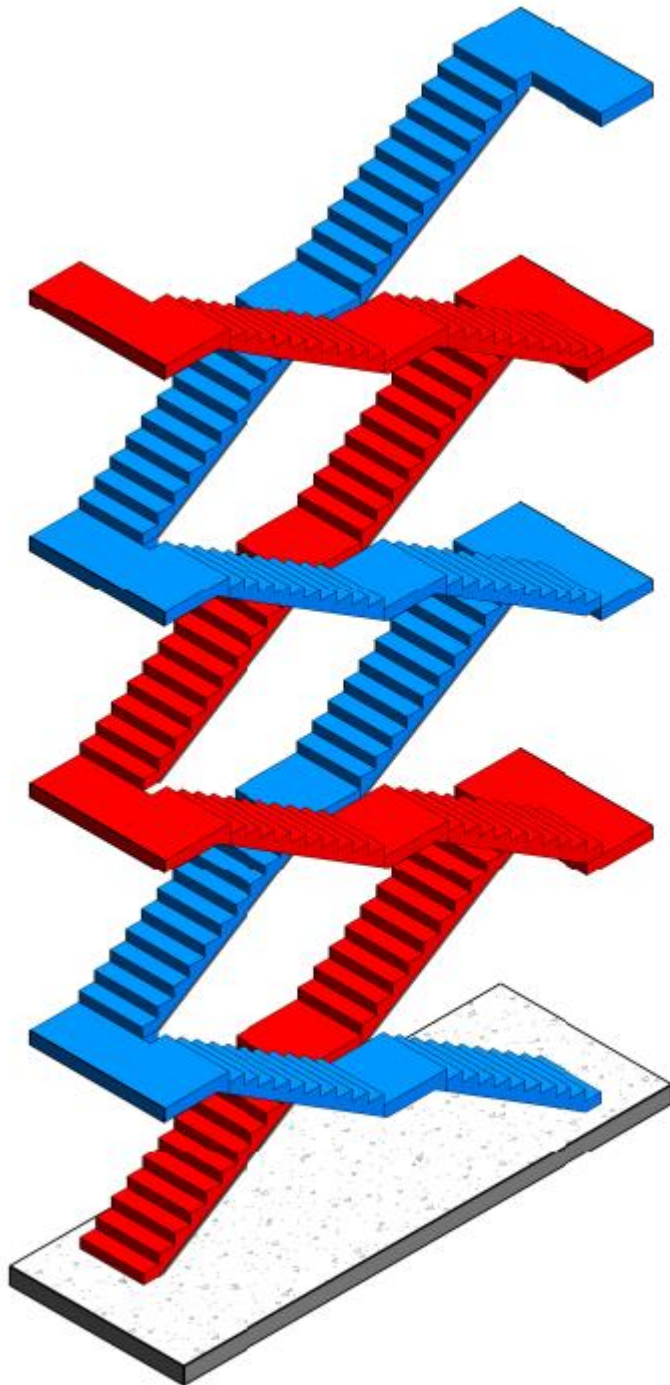

Figure 2 Stair tower – mid-landing discontinuous between shear walls

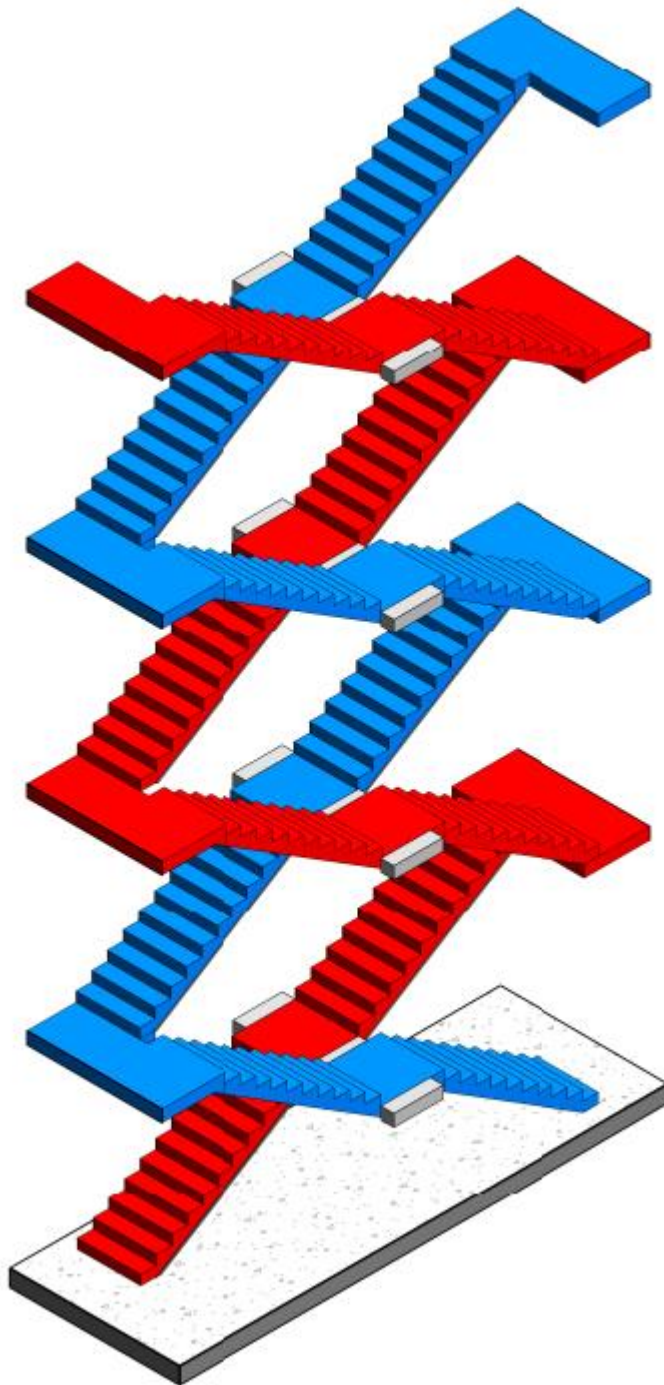

Figure 3 Stair tower – mid-landing continuous between shear walls

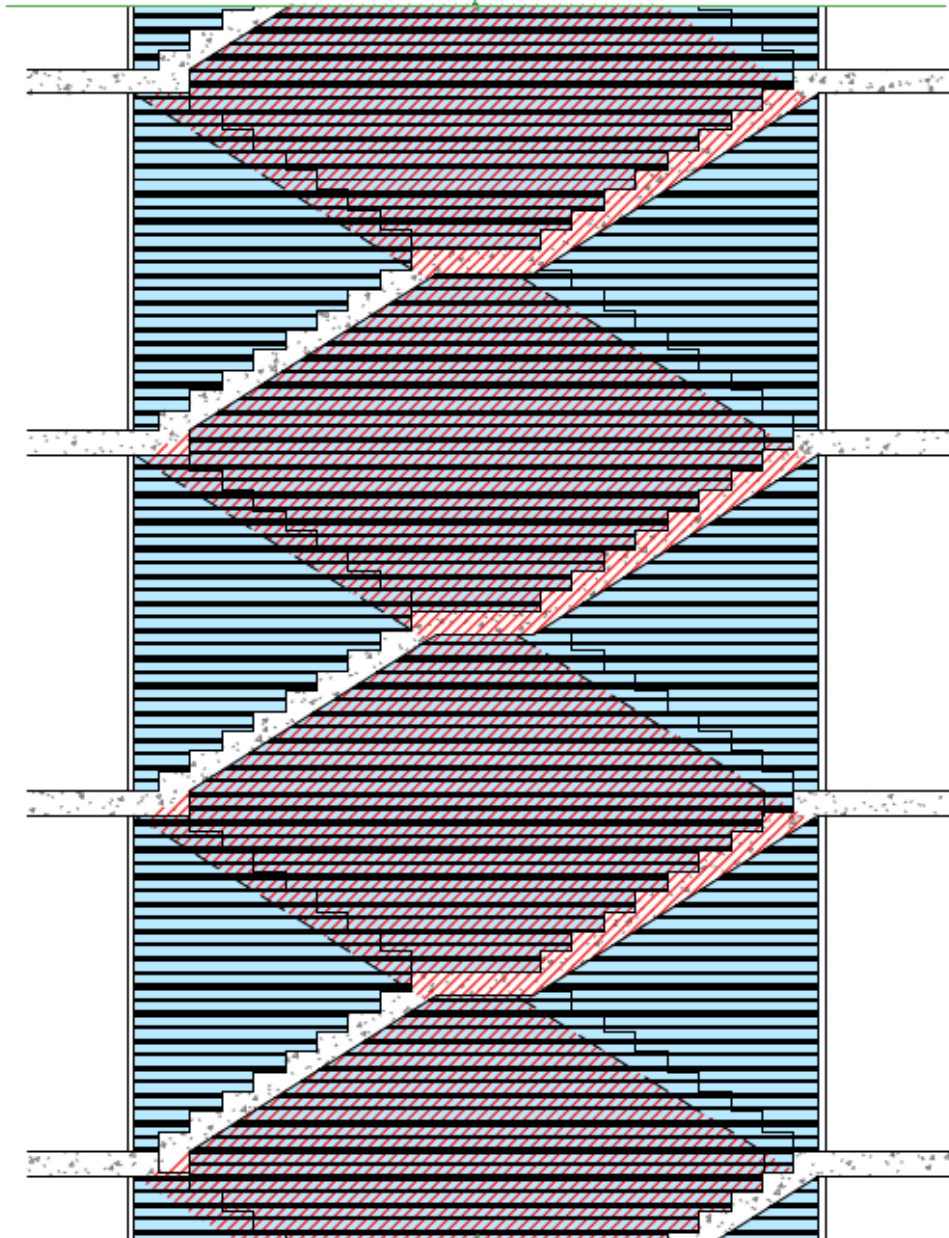

Figure 4 Quadrilateral section providing fire-resistance in the horizontal plane (single stacked wall)

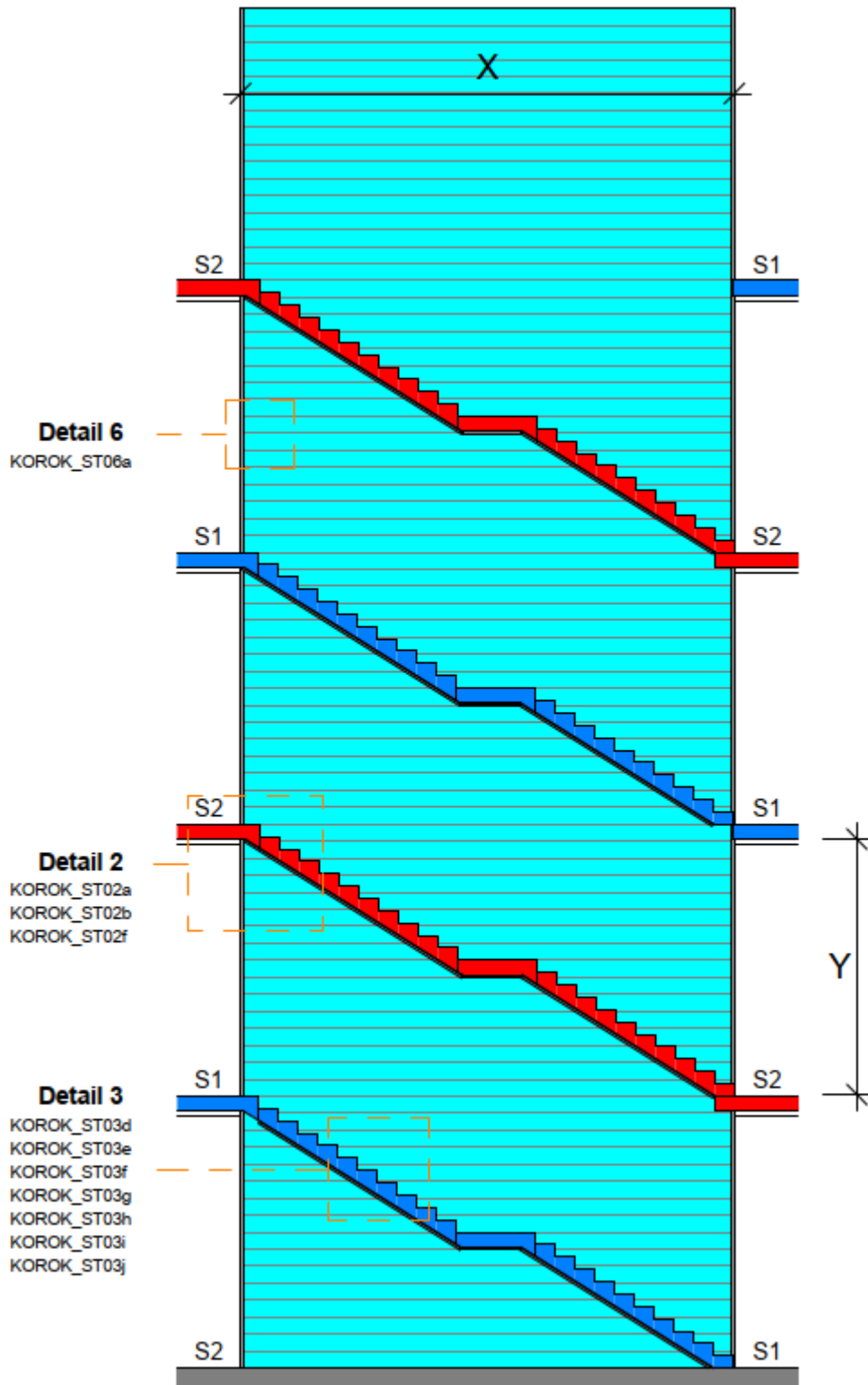

Figure 5 Wall type WT2 with mid-landing discontinuous through KOROK® wall – elevation

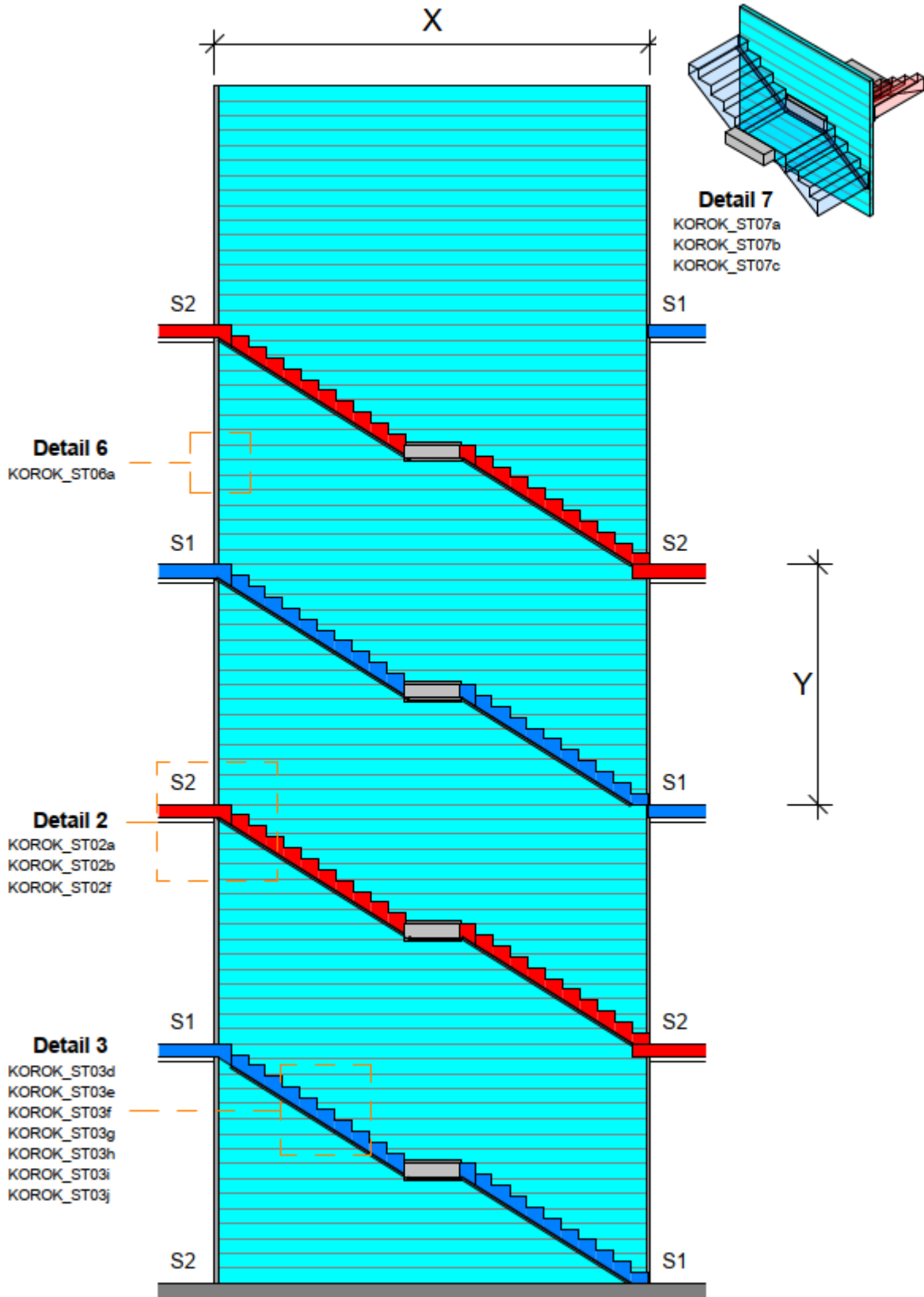

Figure 6 Wall type WT2A with mid-landing continuous through KOROK® wall – elevation

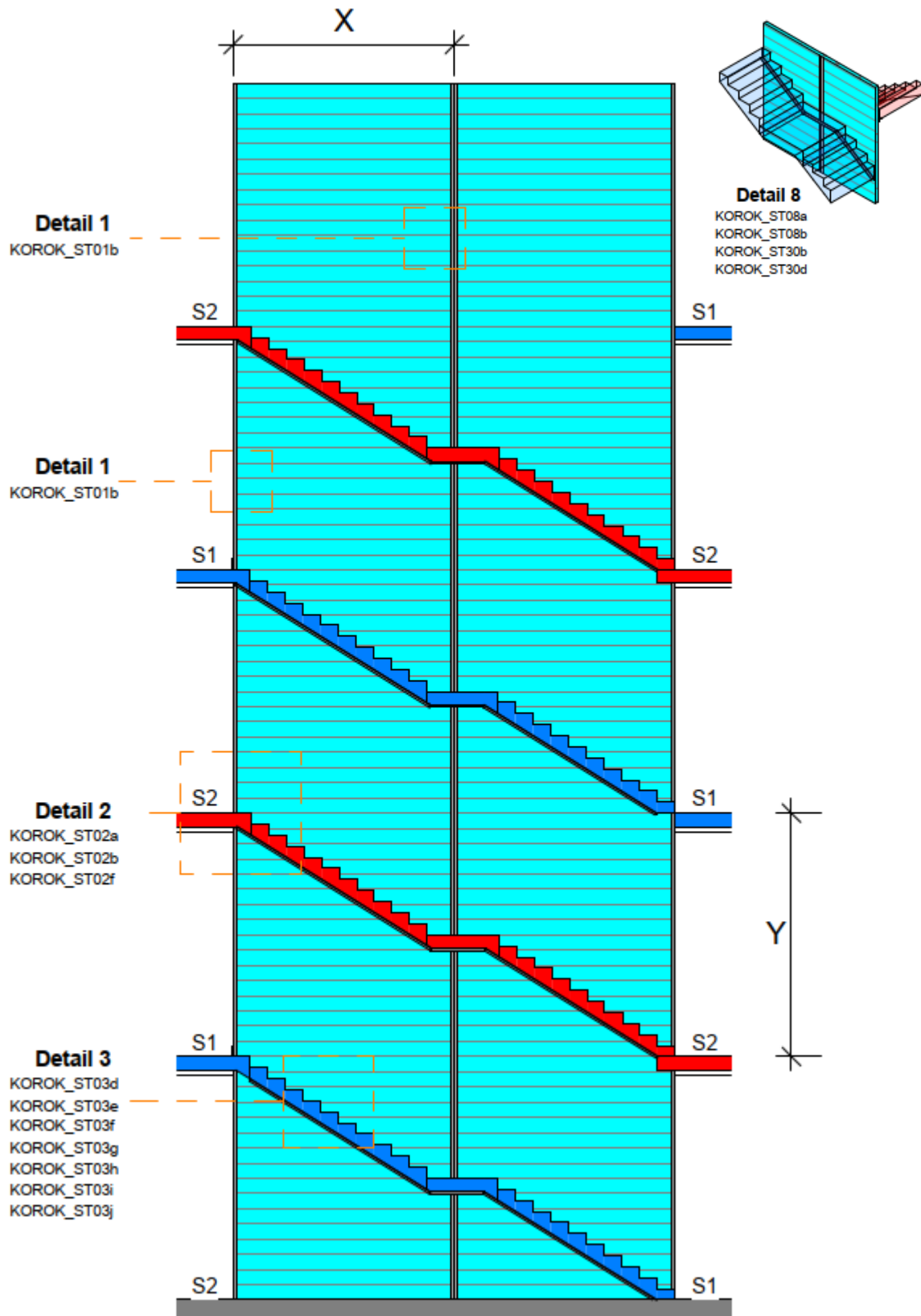

Figure 7 Wall type WT2C with mid-landing discontinuous through KOROK® wall – elevation

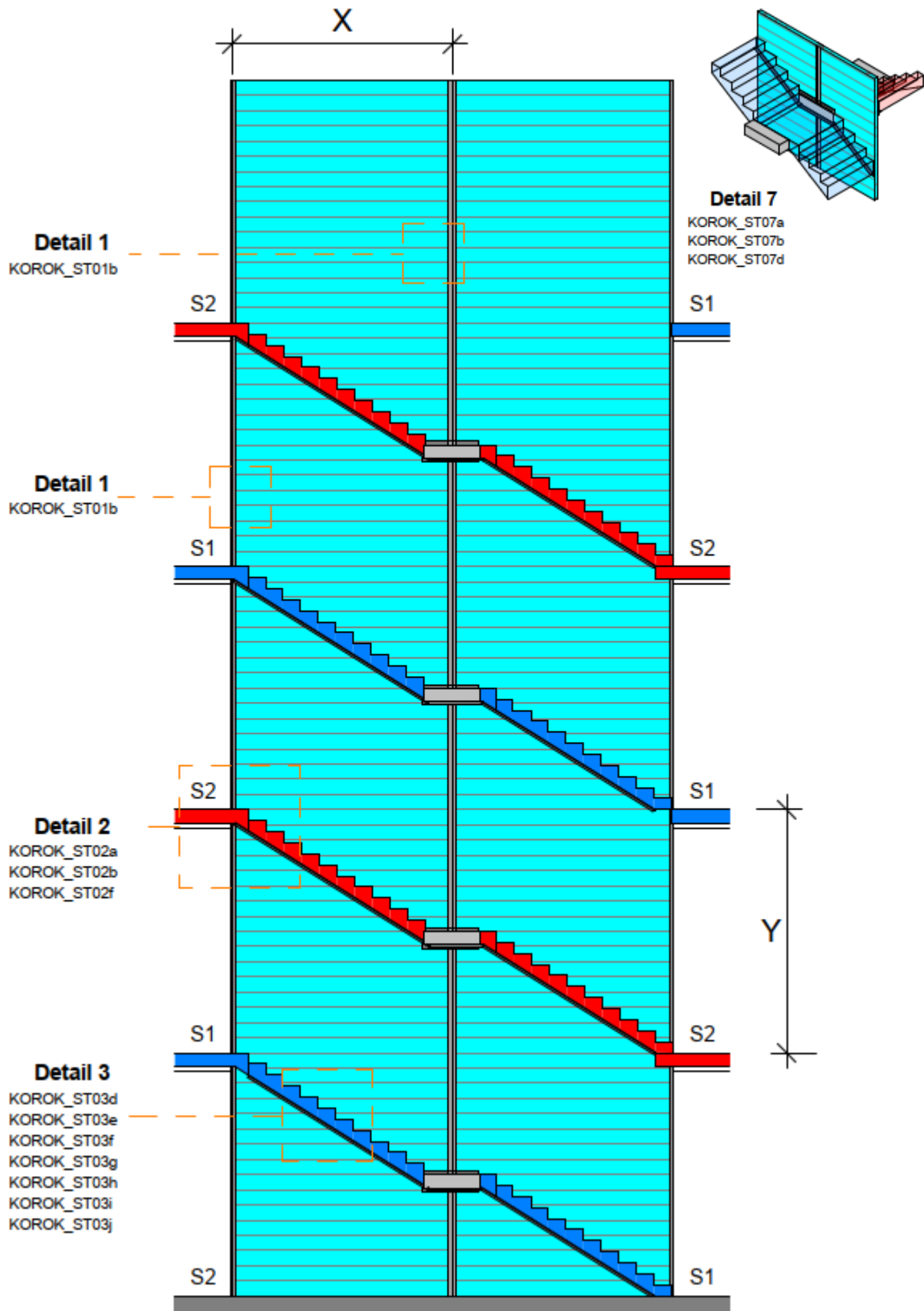

Figure 8 Wall type WT2D with mid-landing continuous through KOROK® wall – elevation

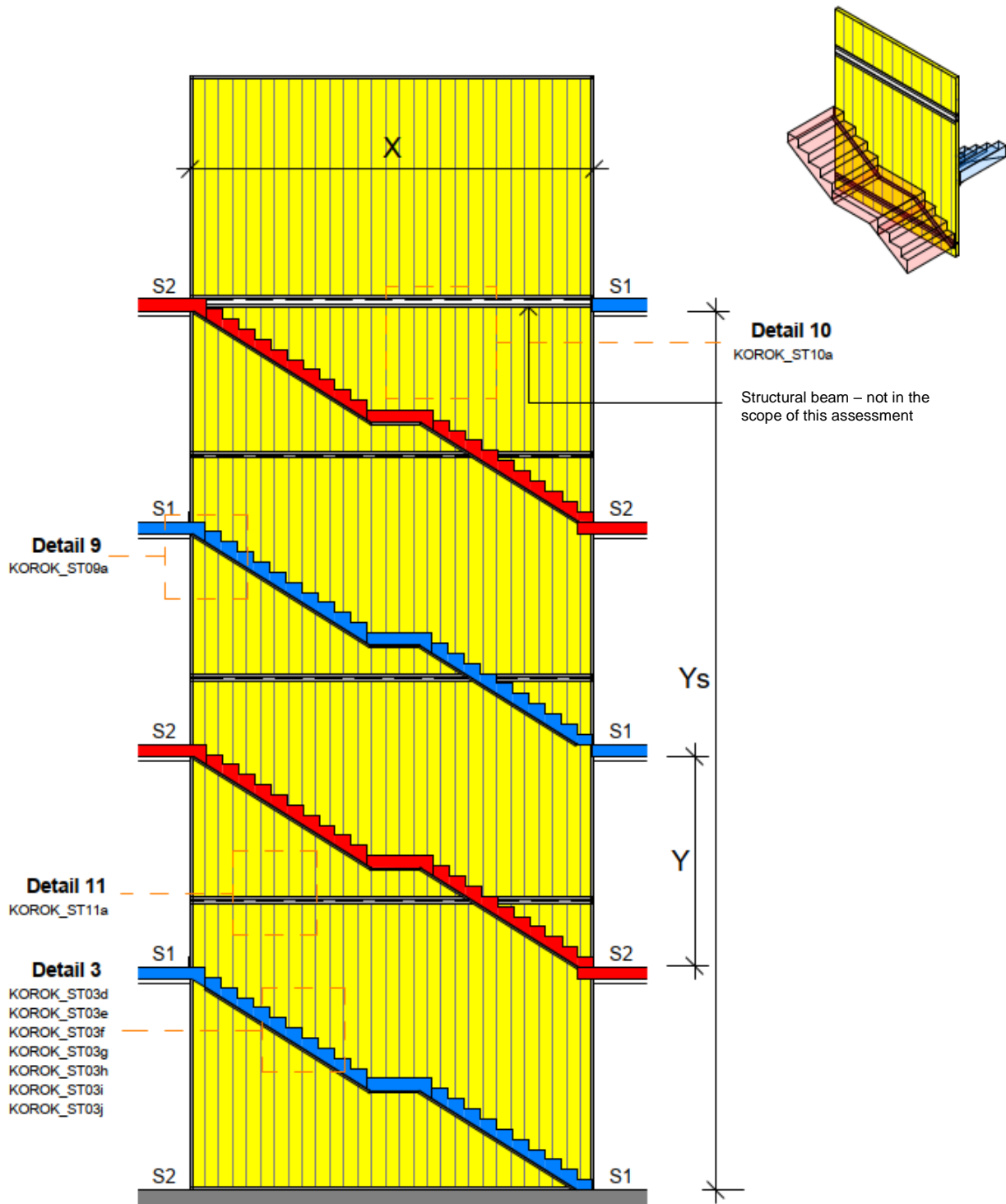

Figure 9 Wall type WT3A with structural beam at the top-most floor level – elevation

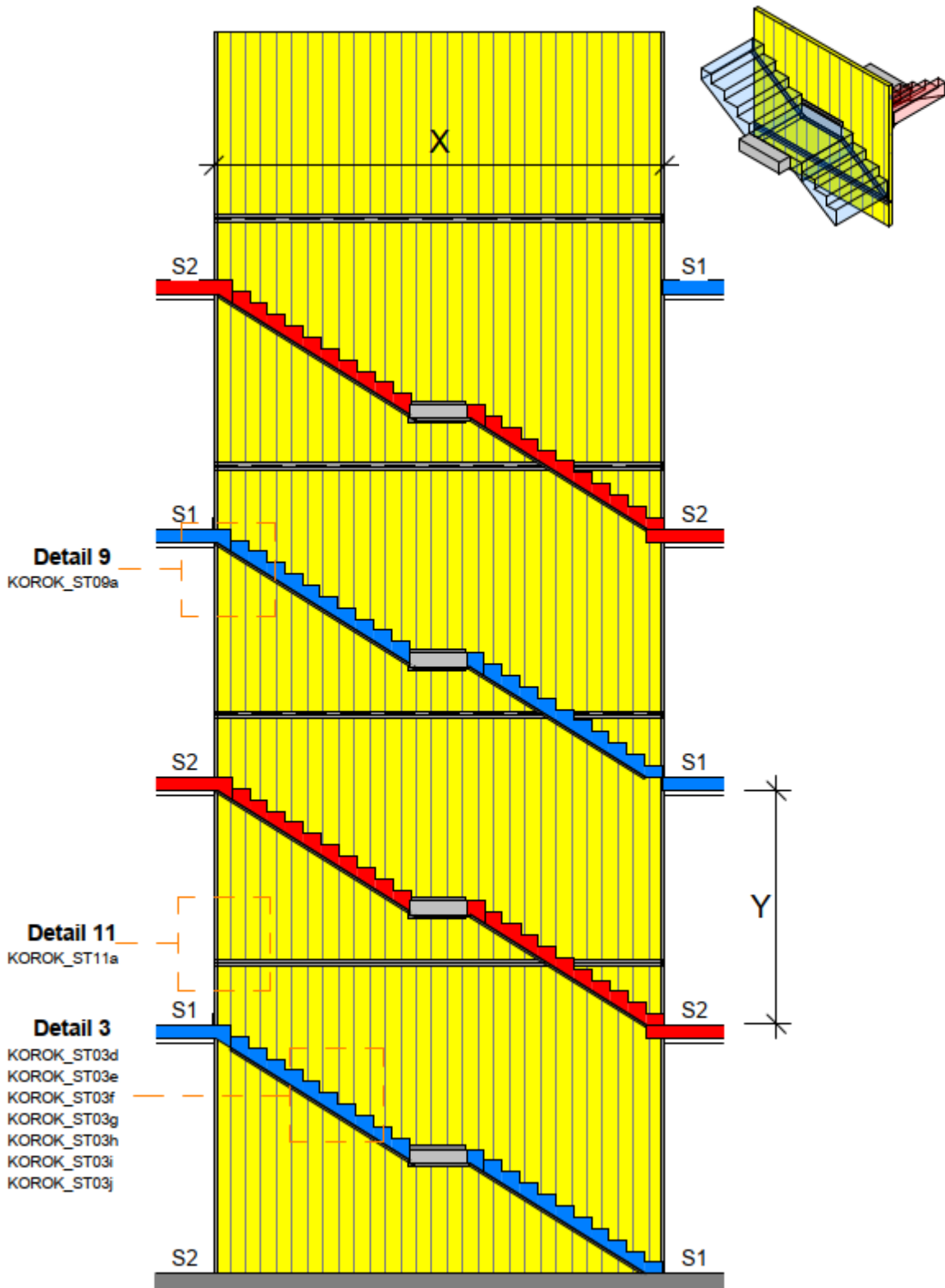

Figure 10 Wall type WT3B with mid-landing continuous through KOROK® wall – elevation

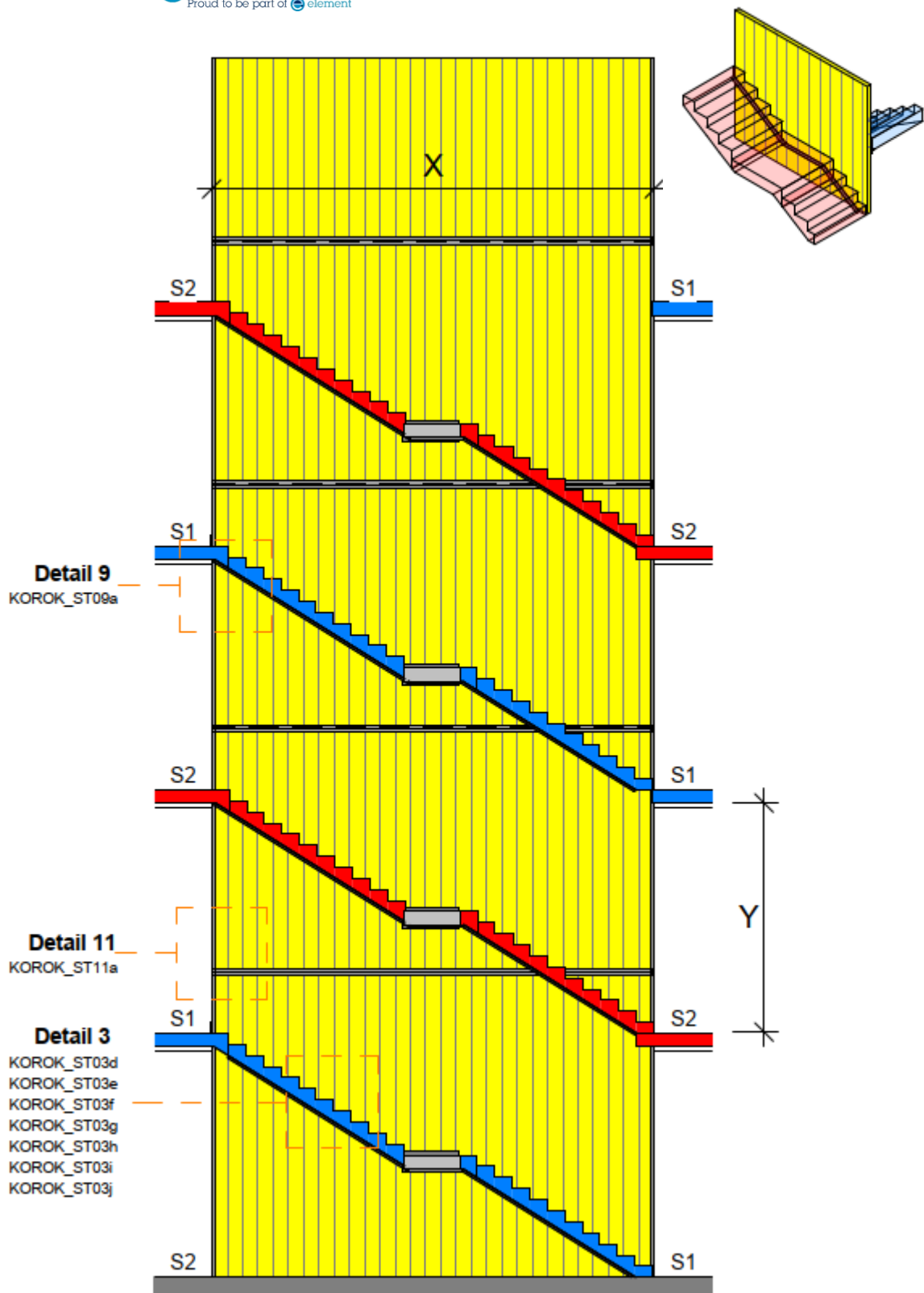

Figure 11 Wall type WT3C with mid-landing discontinuous through KOROK® wall – elevation

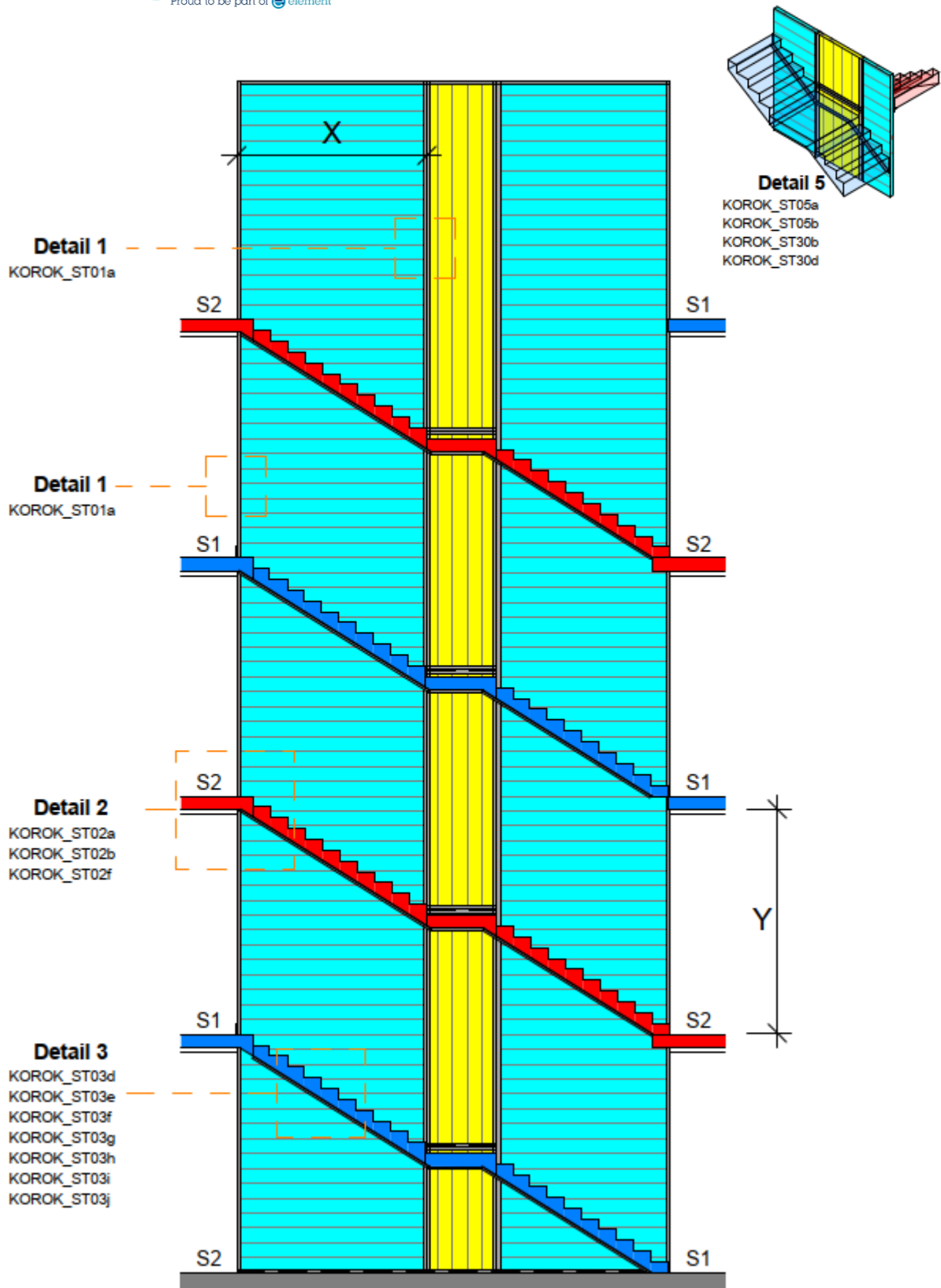

Figure 12 Wall type WT1A with mid-landing discontinuous through KOROK® wall – elevation

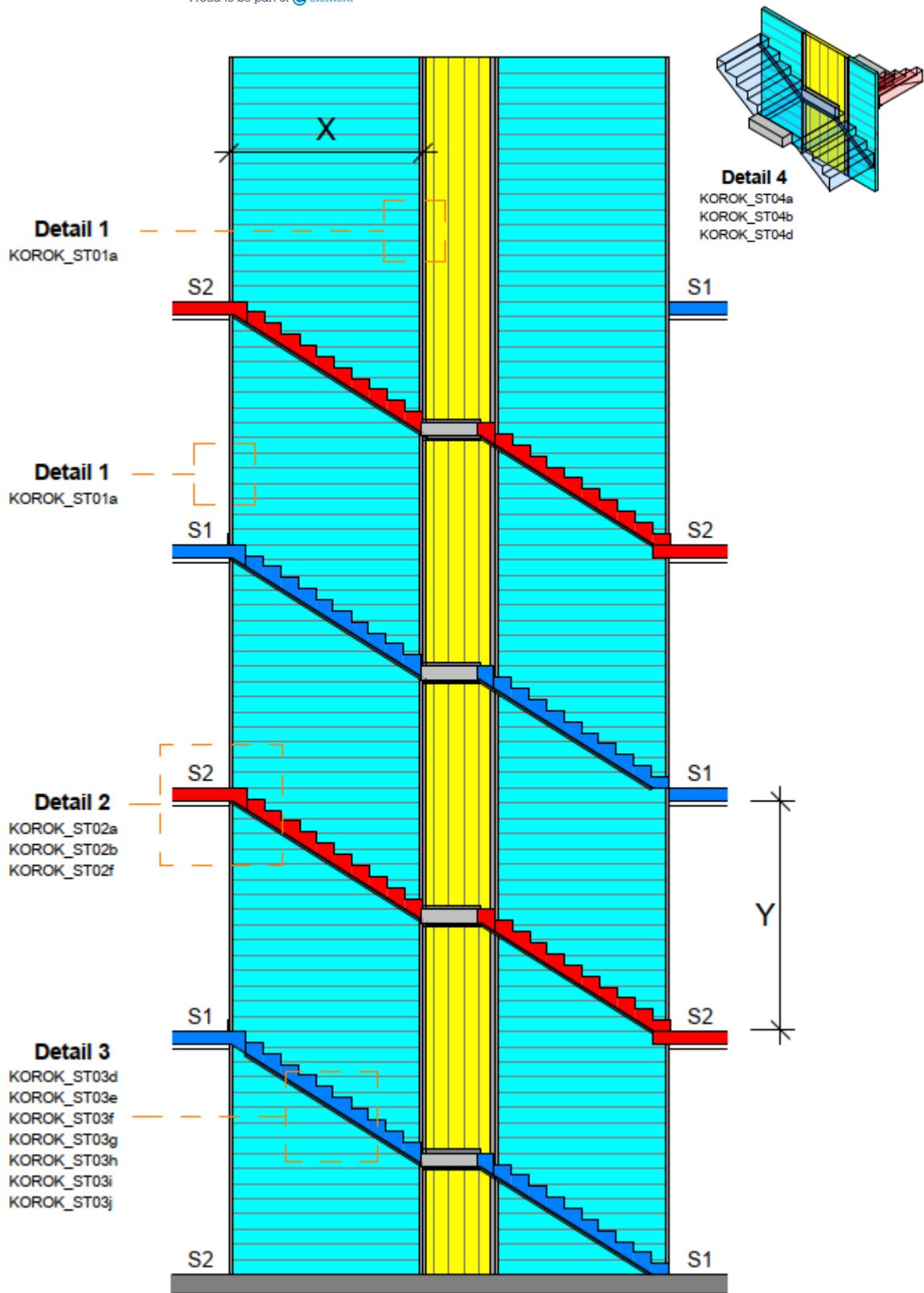

Figure 13 Wall type WT1B with mid-landing continuous through KOROK® wall – elevation

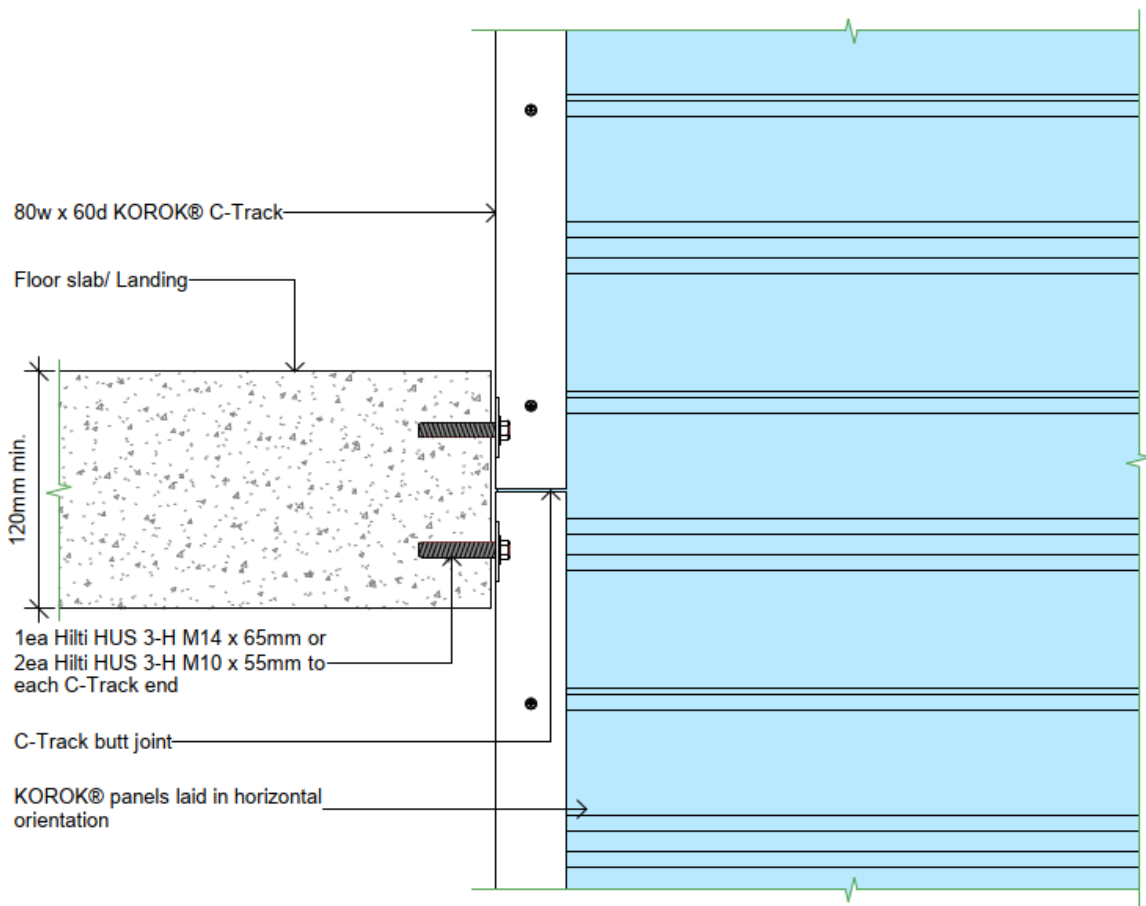

Figure 14 Connection between C-track and landings – elevation (Detail 2 as denoted in Figure 5, Figure 6, Figure 7 and Figure 8)

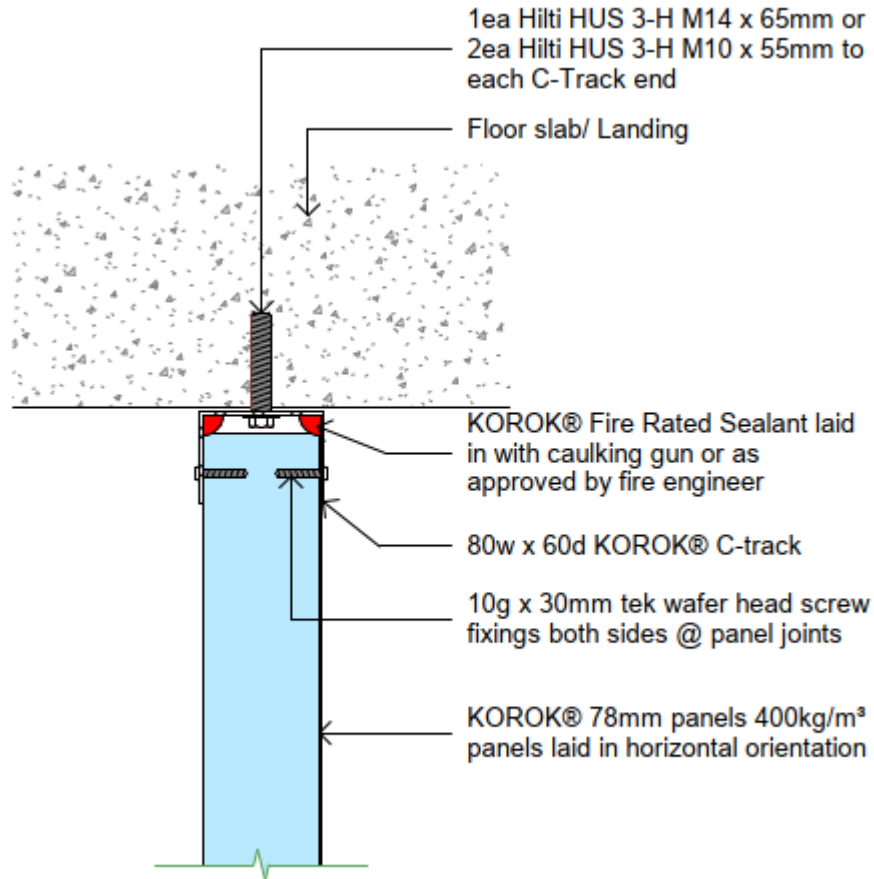

Figure 15 Connection between C-track and landings – plan view (Detail 2 as denoted in Figure 5, Figure 6, Figure 7 and Figure 8)

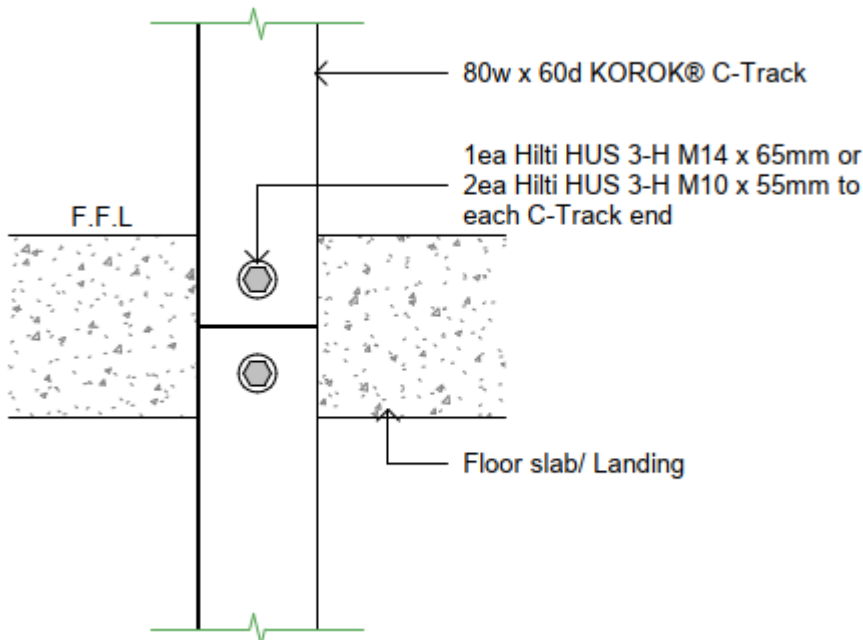

Figure 16 Connection between C-track and landings – section view (Detail 2 as denoted in Figure 5, Figure 6, Figure 7 and Figure 8)

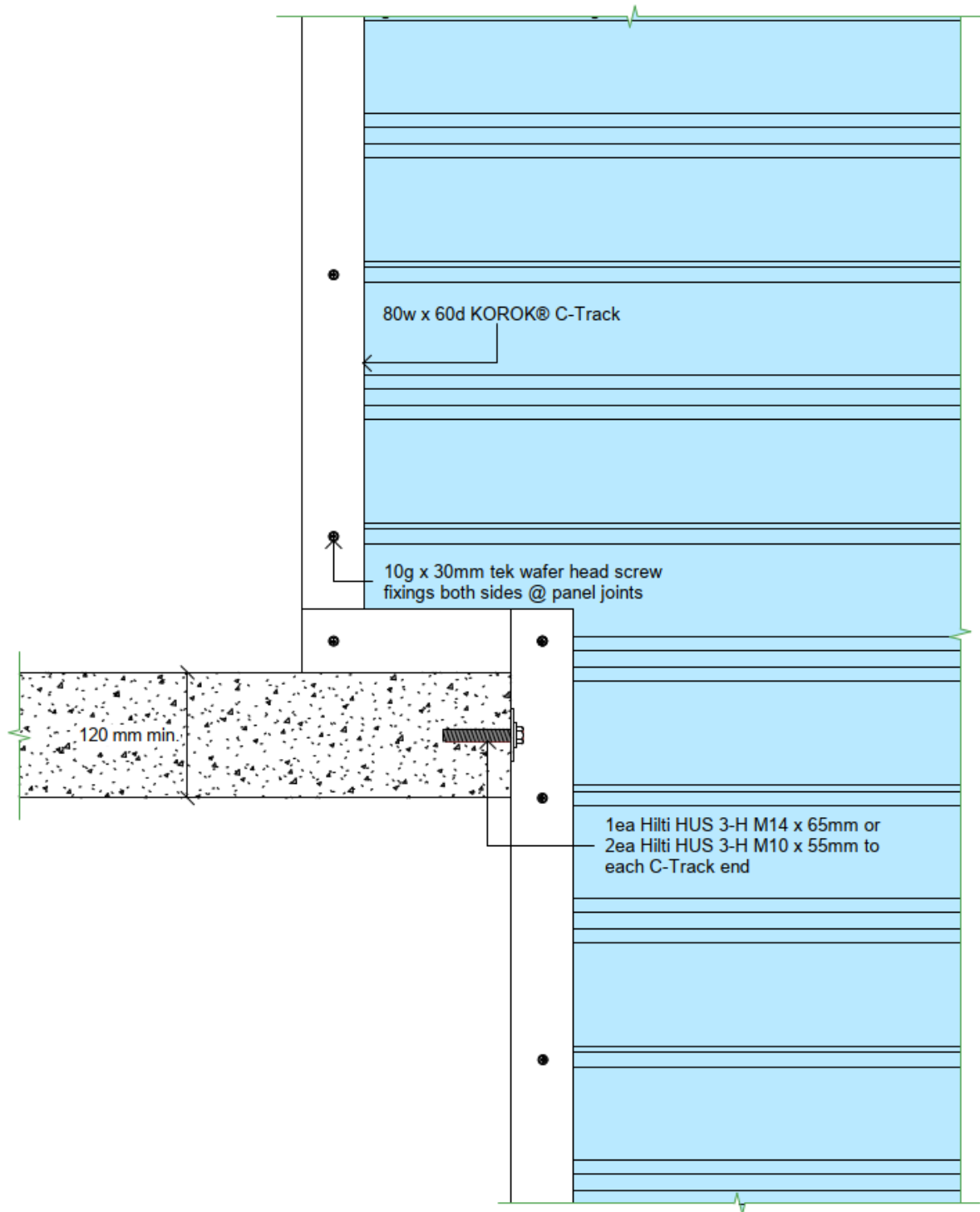

Figure 17 Connection between C-track and landings – stepped landings (Detail 2 as denoted in Figure 5, Figure 6, Figure 7 and Figure 8)

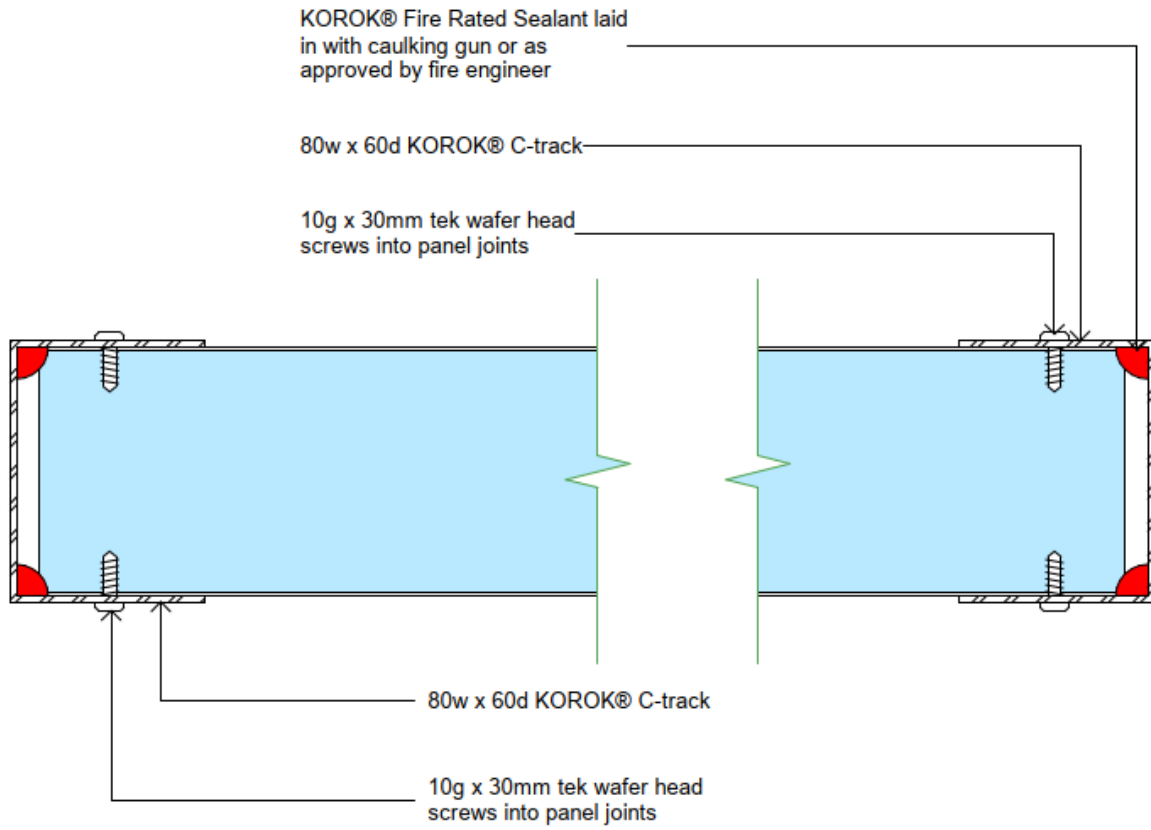

Figure 18 C-track at vertical edges – plan view (Detail 6 as denoted in Figure 5 and Figure 6)

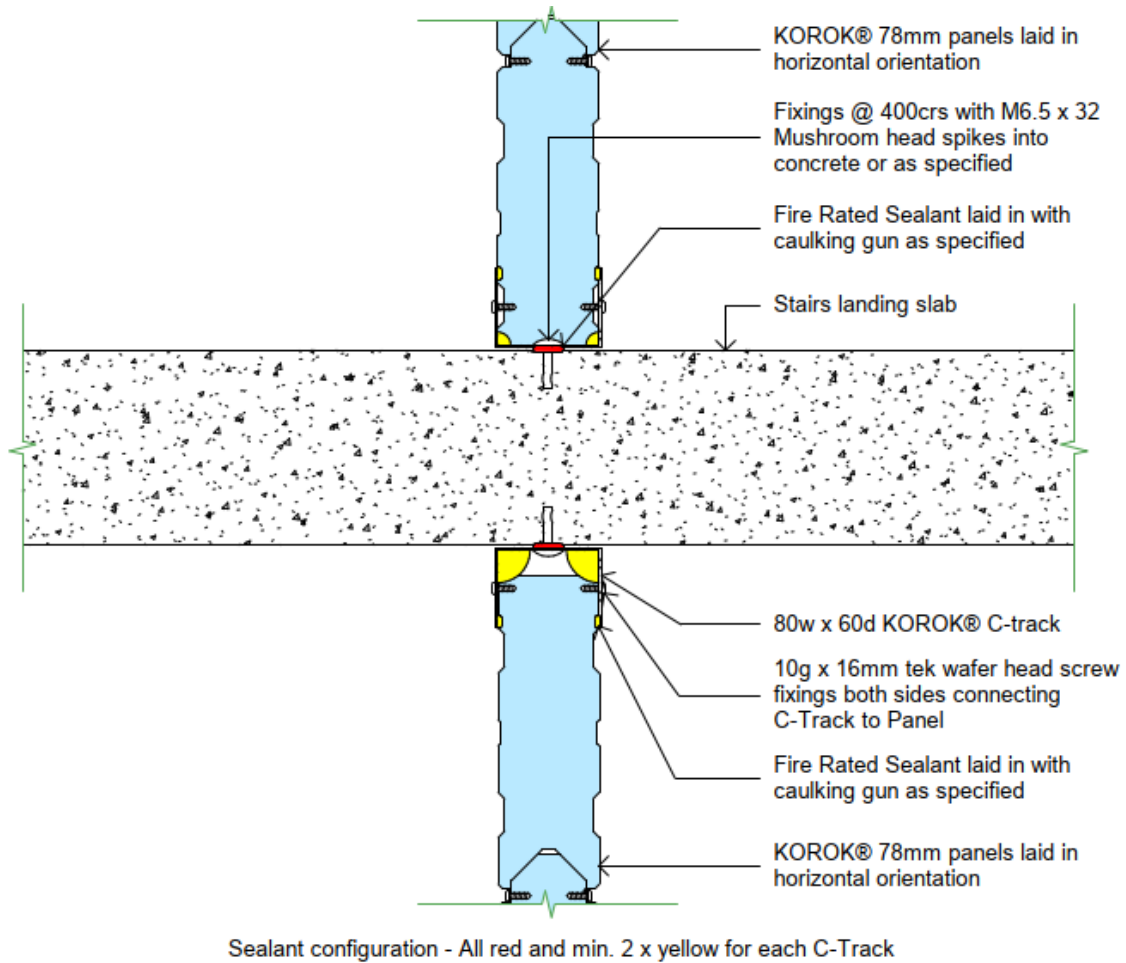
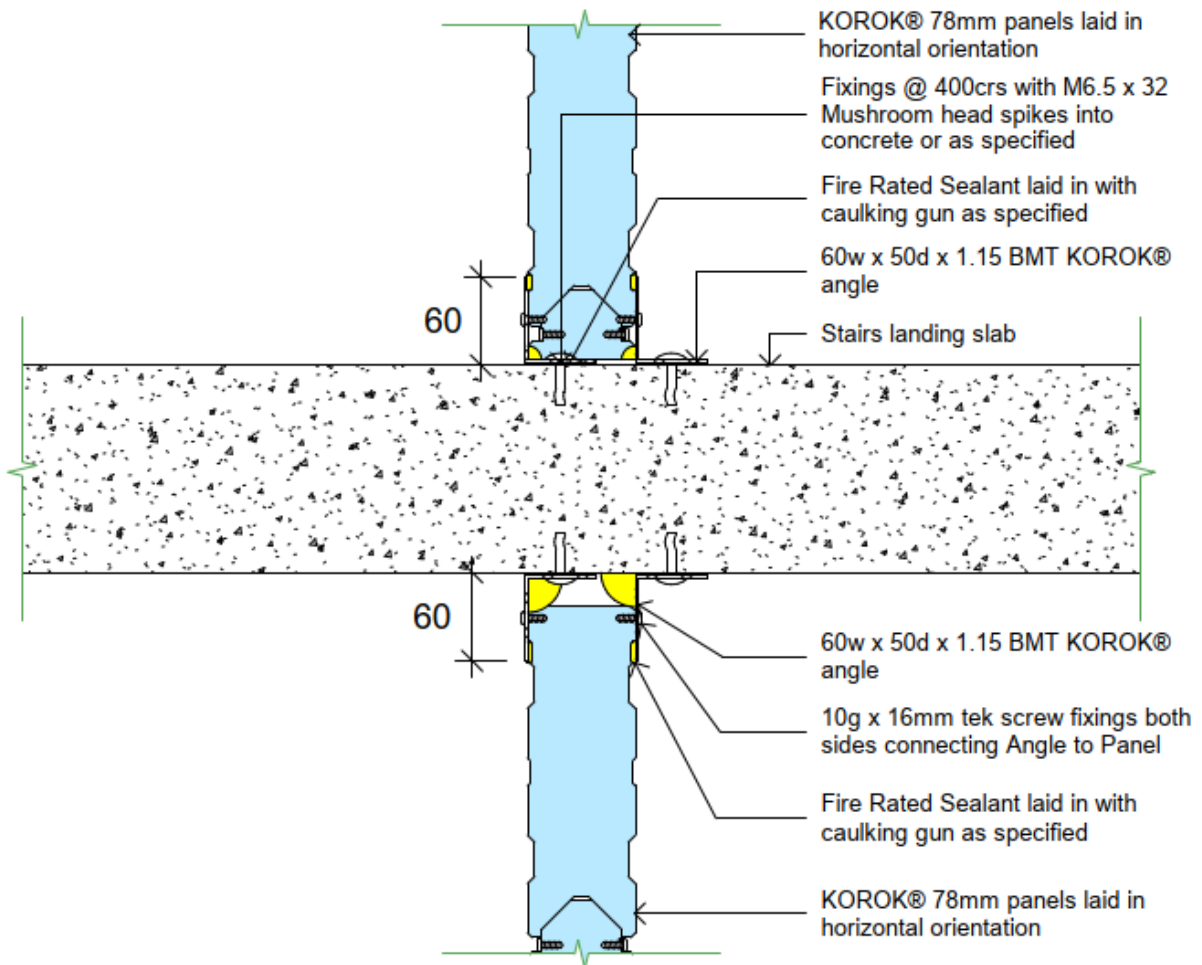
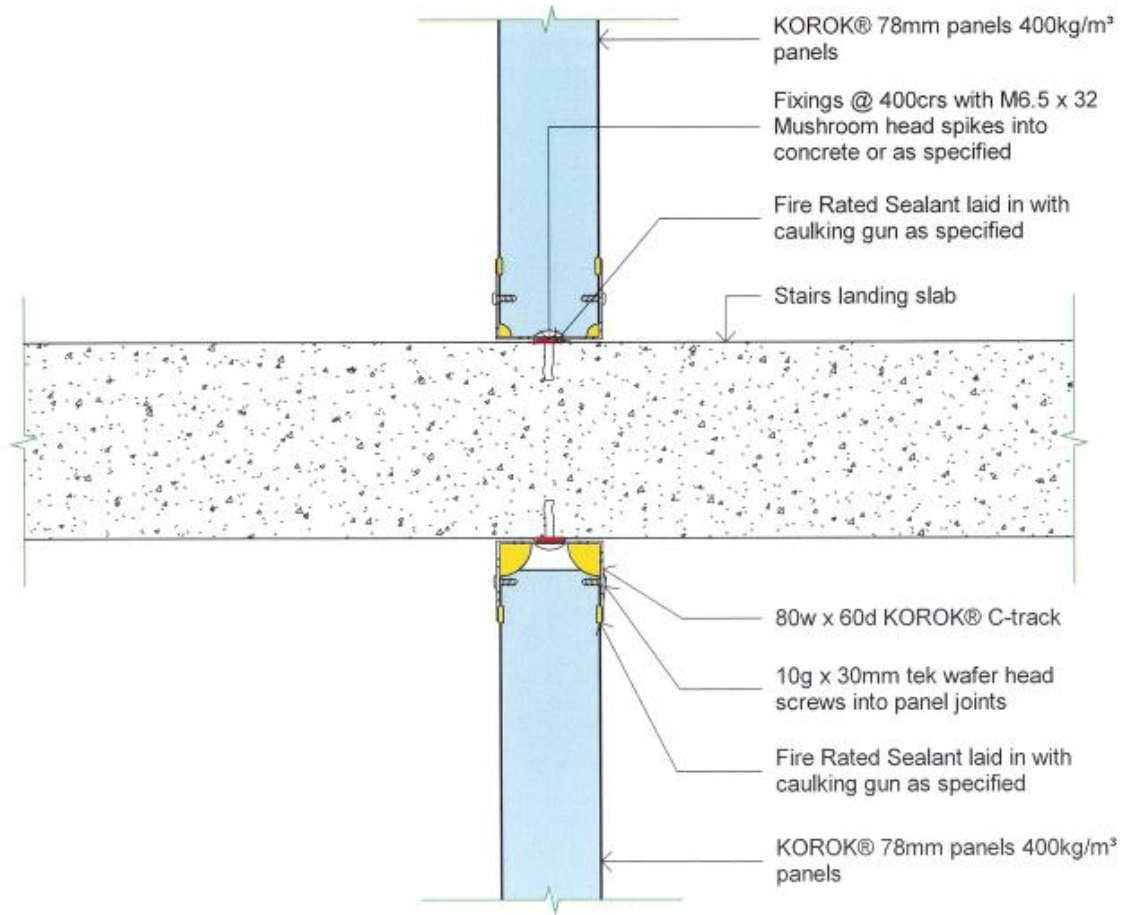

Figure 19 Mid-landing which is continuous across horizontal KOROK® wall – section view (Detail 7 as denoted in Figure 6 and Figure 8) – for a maximum FRL of -/120/60



Sealant configuration - All red and min. 2 x yellow for each C-Track

Figure 20 Mid-landing which is continuous across horizontal KOROK® wall – section view (alternative Detail 7 as denoted in Figure 6 and Figure 8) – for a maximum FRL of - /120/120



Sealant configuration - All red and min. 2 x yellow for each C-Track

Figure 21 Mid-landing which is continuous across vertical KOROK® wall – section view (as denoted in Figure 10 and Figure 13) – for a maximum FRL of -/120/60

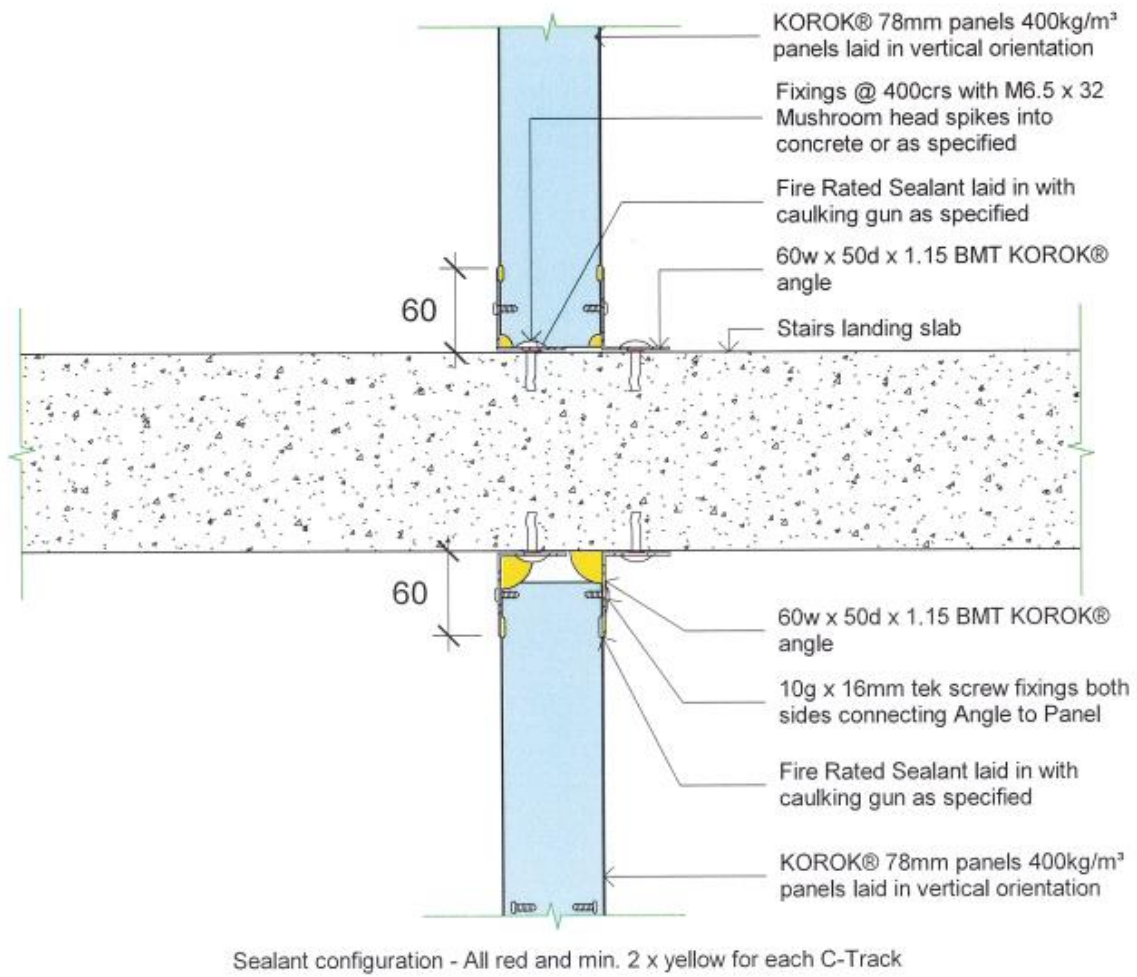

Figure 22 Mid-landing which is continuous across vertical KOROK® wall – section view (as denoted in Figure 10 and Figure 13) – for a maximum FRL of -/120/120

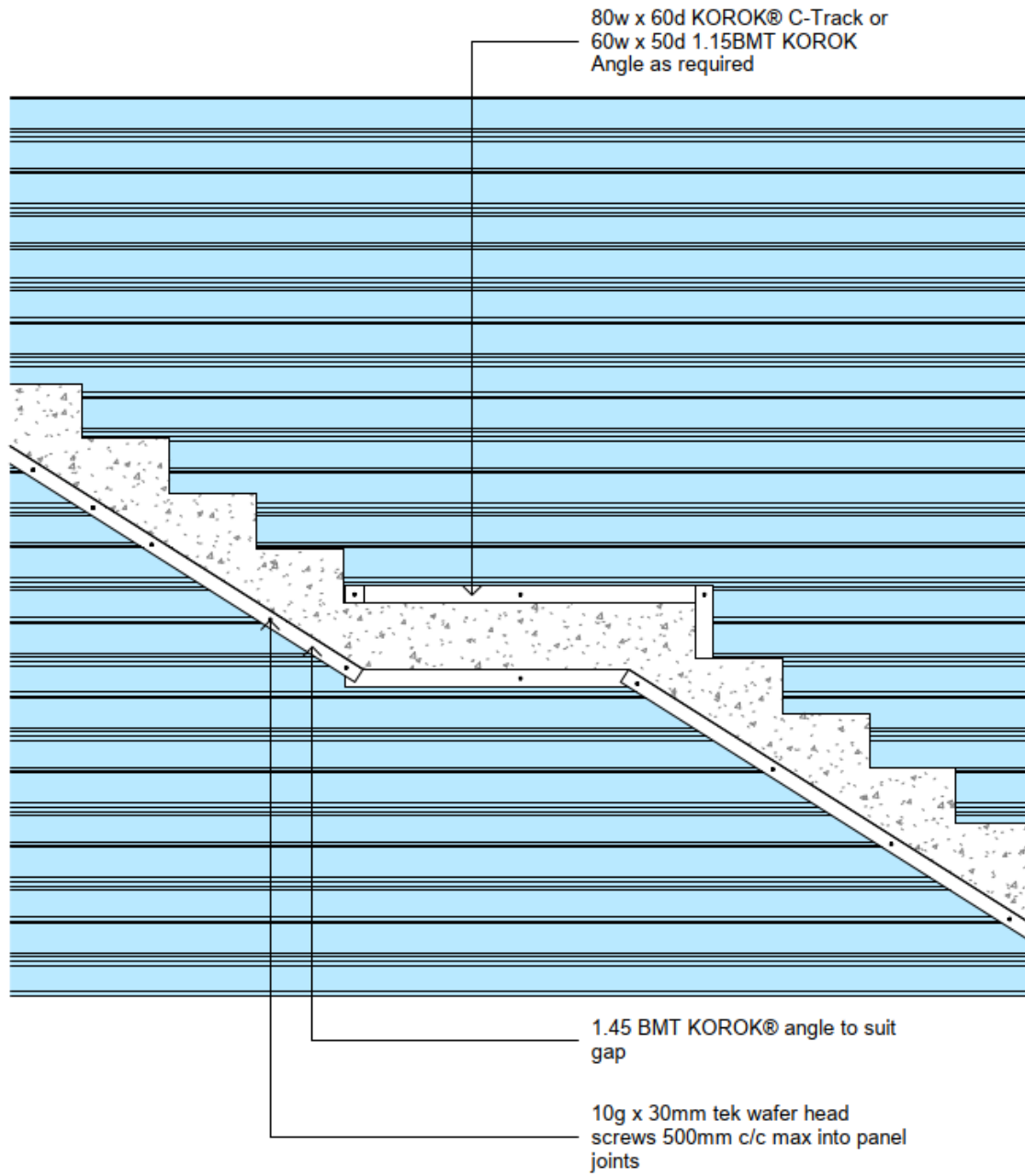

Figure 23 Mid-landing for WT2A – elevation (Detail 7 as denoted in Figure 6)

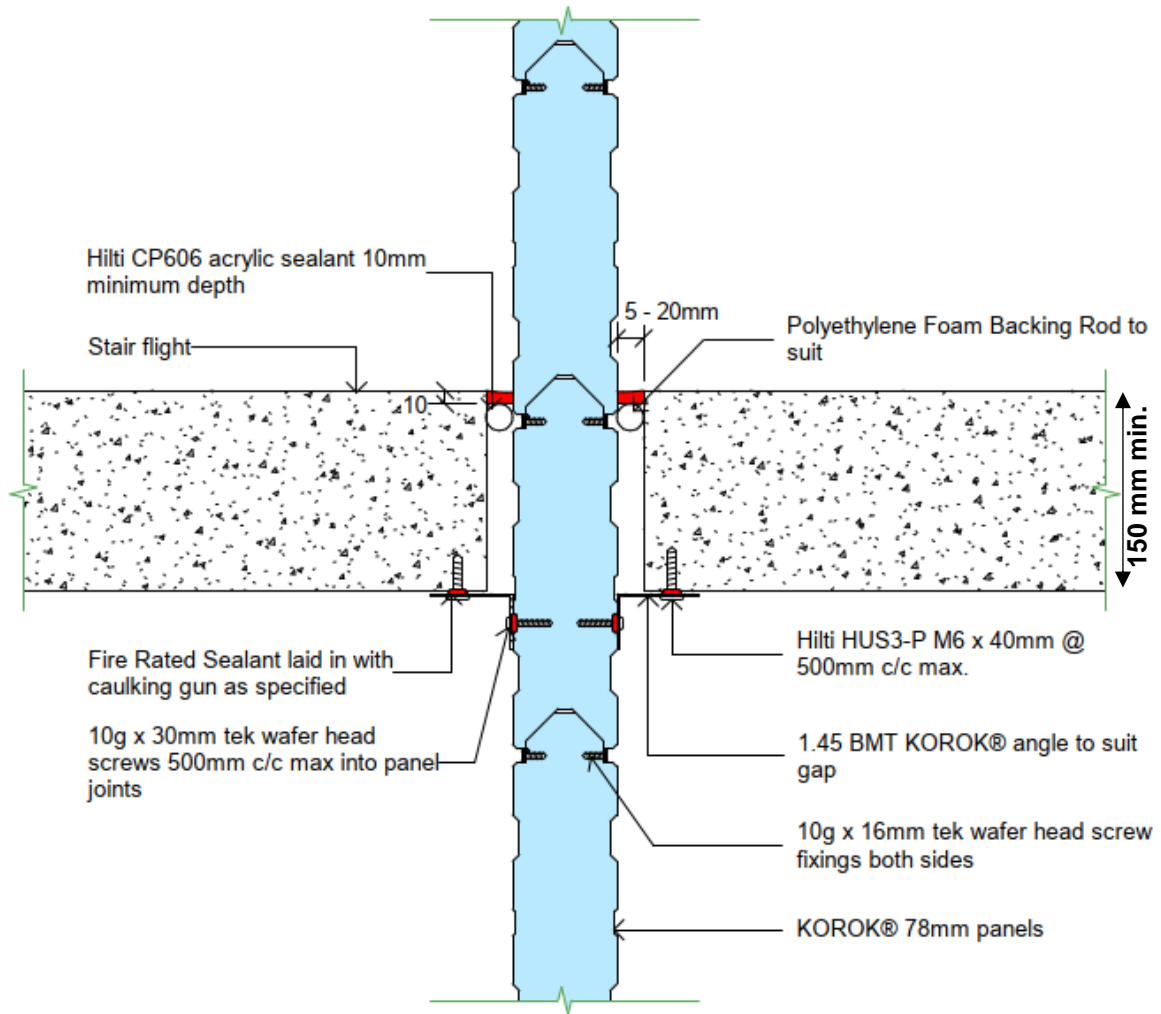

Figure 24 5 mm – 20 mm wide joint between KOROK® wall and stair stringer – protected with Hilti CP606 and PE backing rods

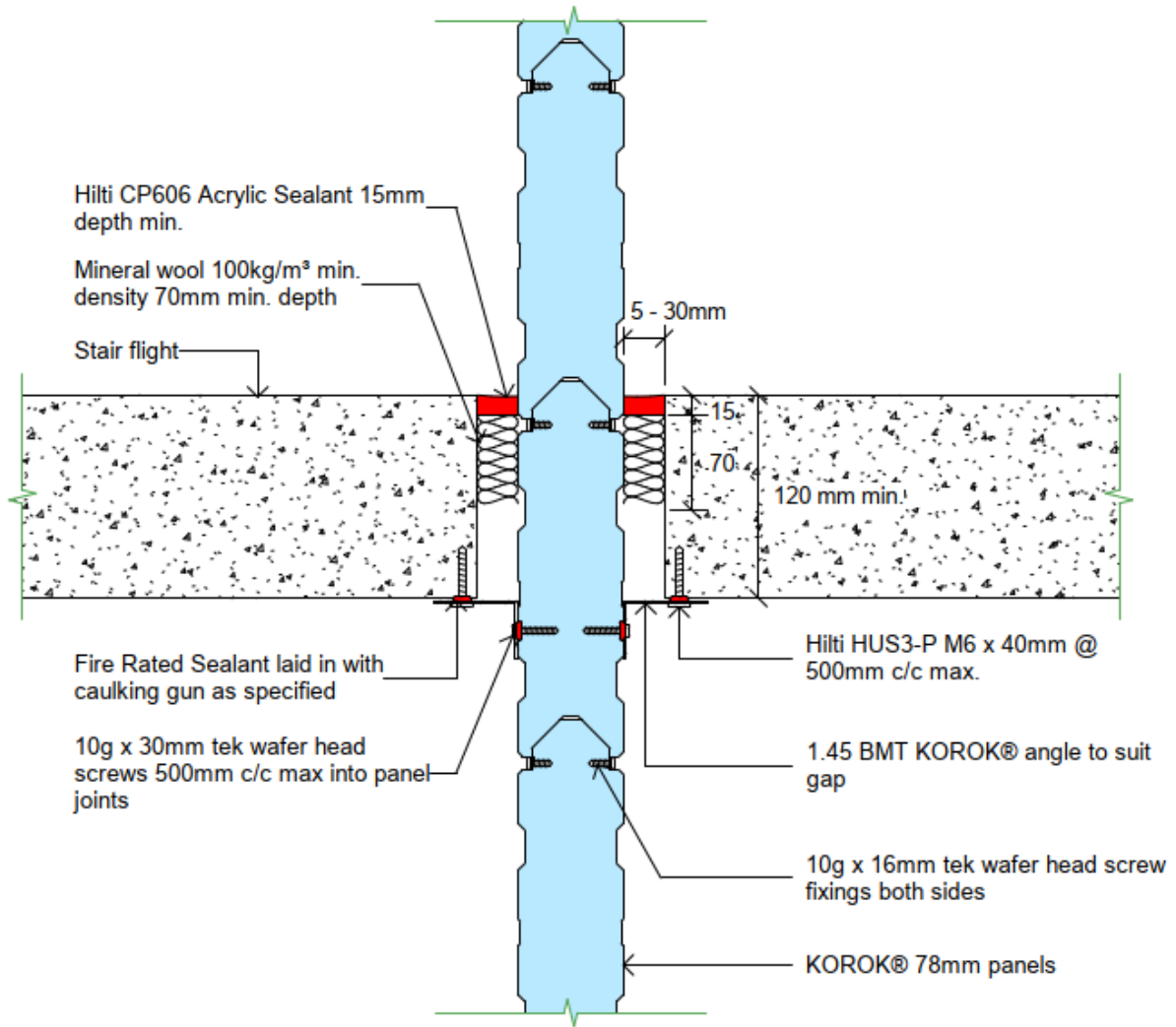

Figure 25 5 mm – 30 mm wide joint between KOROK® wall and stair stringer – protected with Hilti CP606 and mineral wool

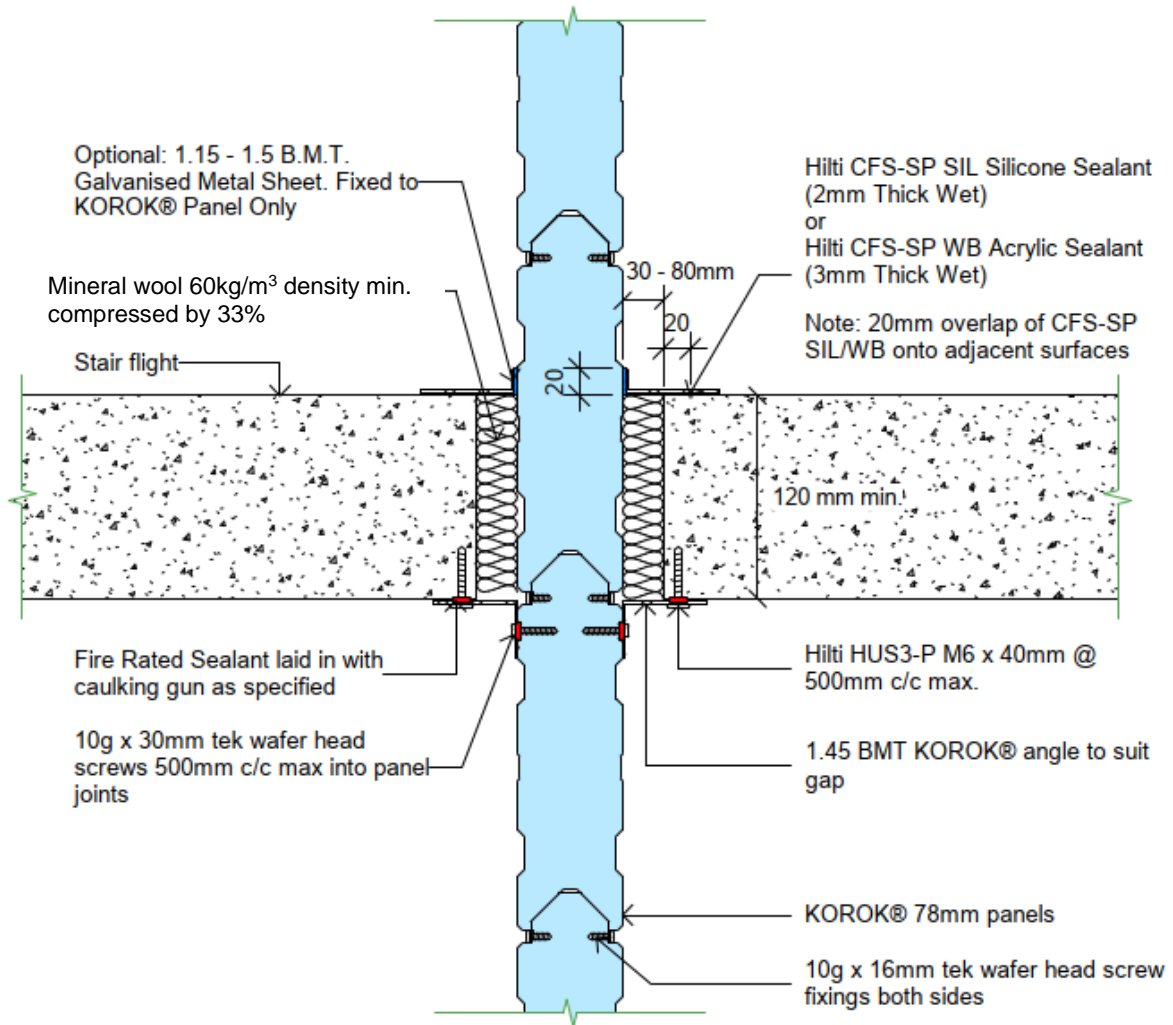

Figure 26 30 mm – 80 mm wide joint between KOROK® wall and stair stringer – protected with mineral wool and Hilti CFS-SP SIL or Hilti CFS-SP WB sealants

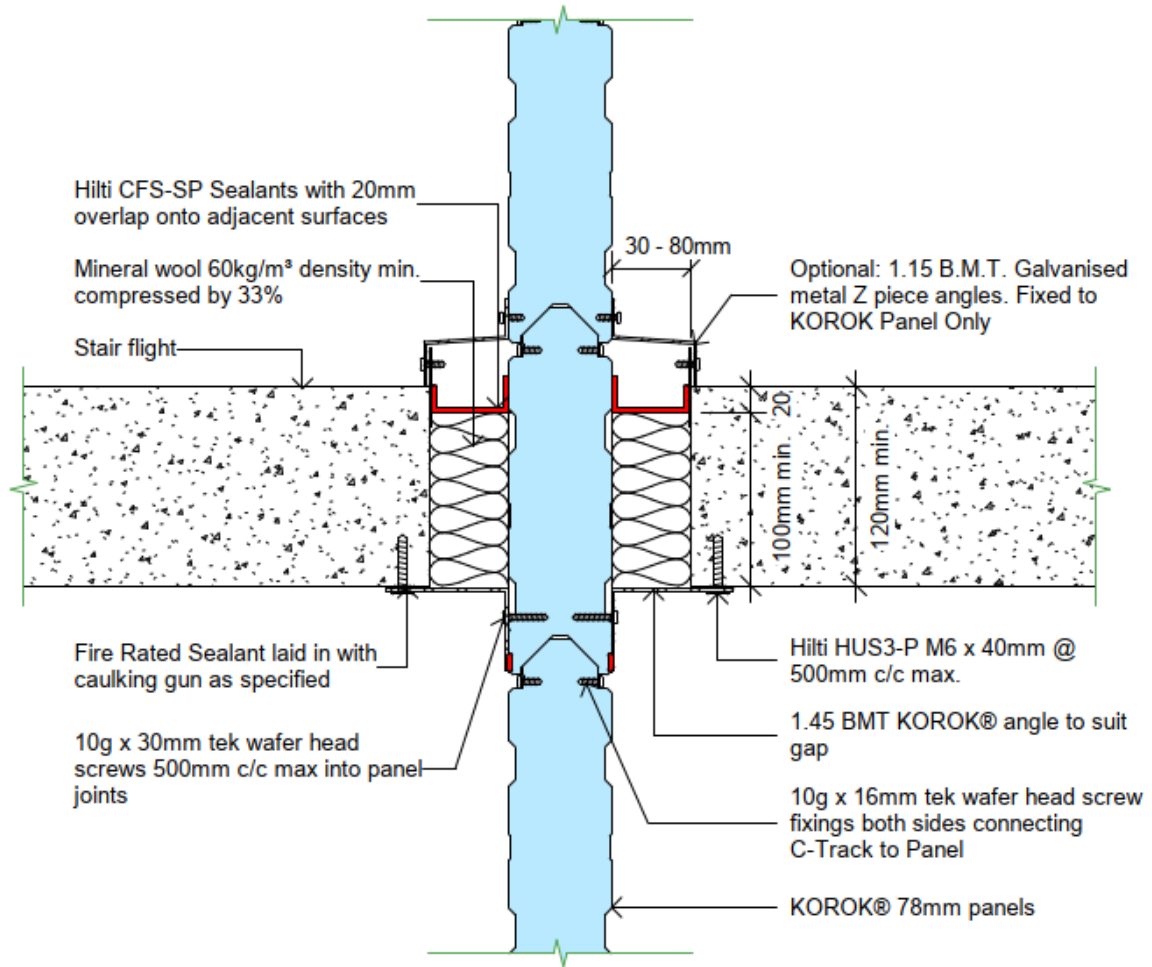

Figure 27 30 mm – 80 mm wide joint between KOROK® wall and stair stringer – protected with mineral wool and Hilti CFS-SP SIL or Hilti CFS-SP WB sealants

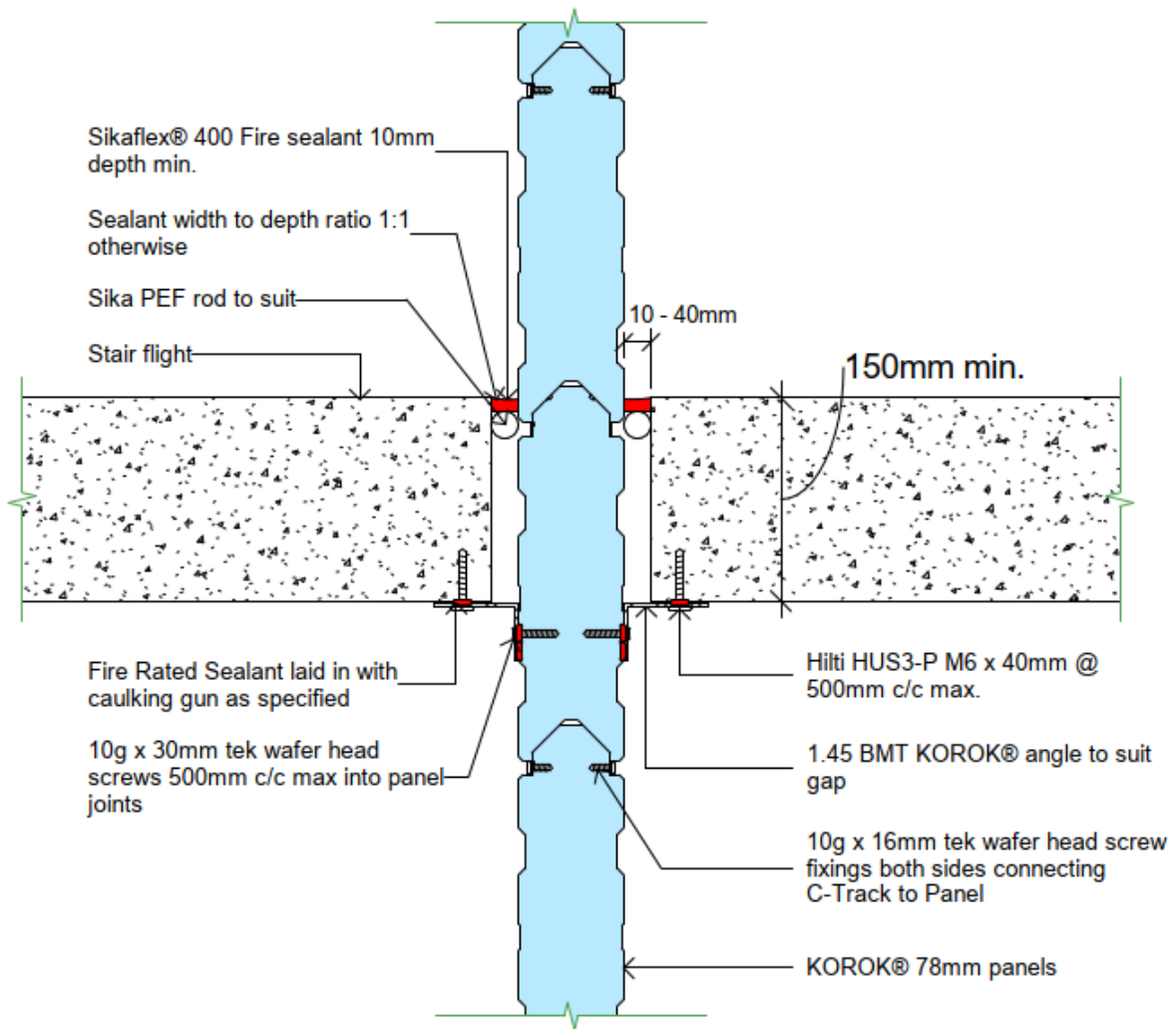

Figure 28 10 mm – 40 mm wide joint between KOROK® wall and stair stringer – protected with Sikaflex® 400 sealant and Sika PEF backing rods

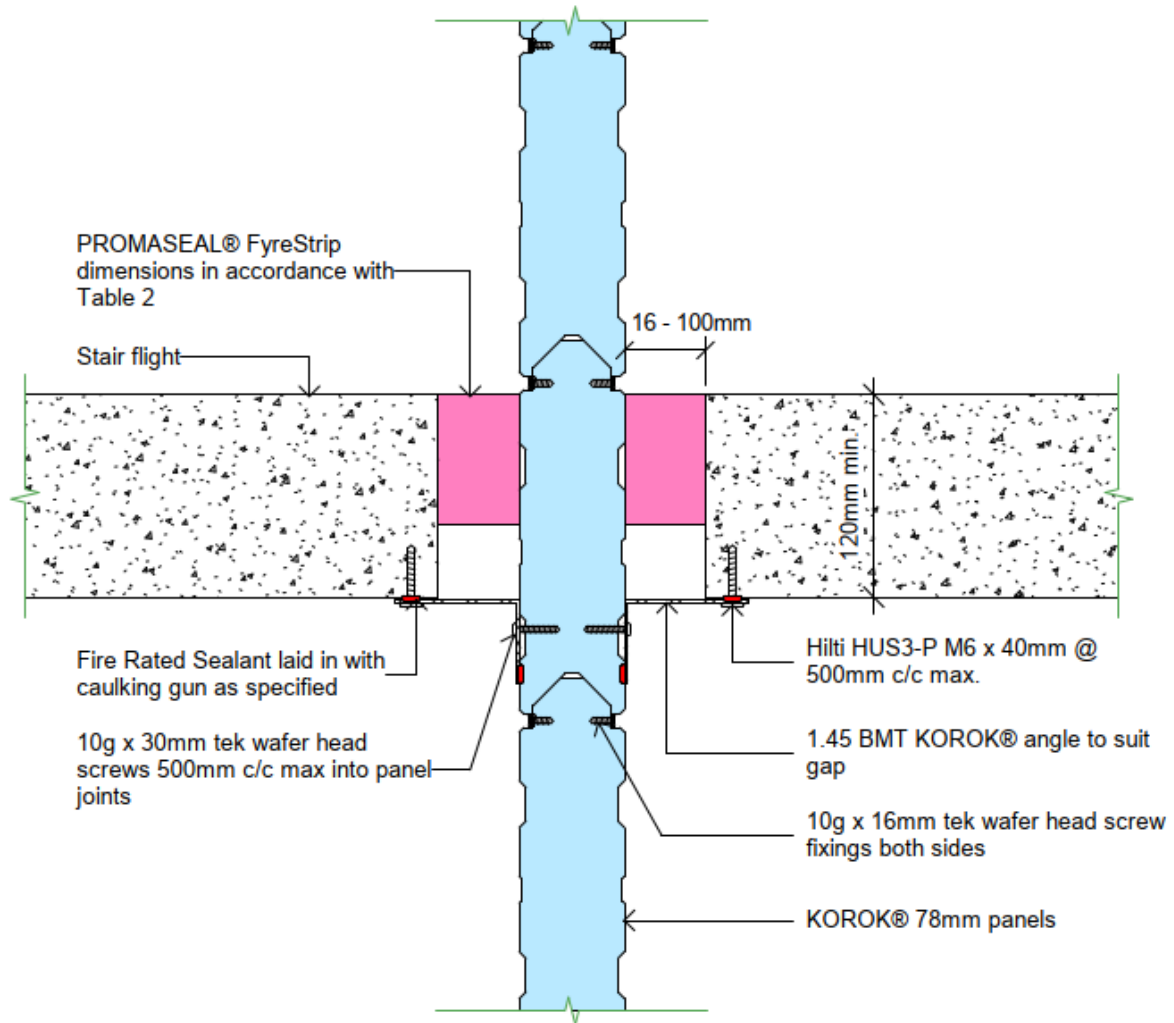

Figure 29 16 mm – 100 mm wide joint between KOROK® wall and stair stringer – protected with PROMASEAL® FyreStrip

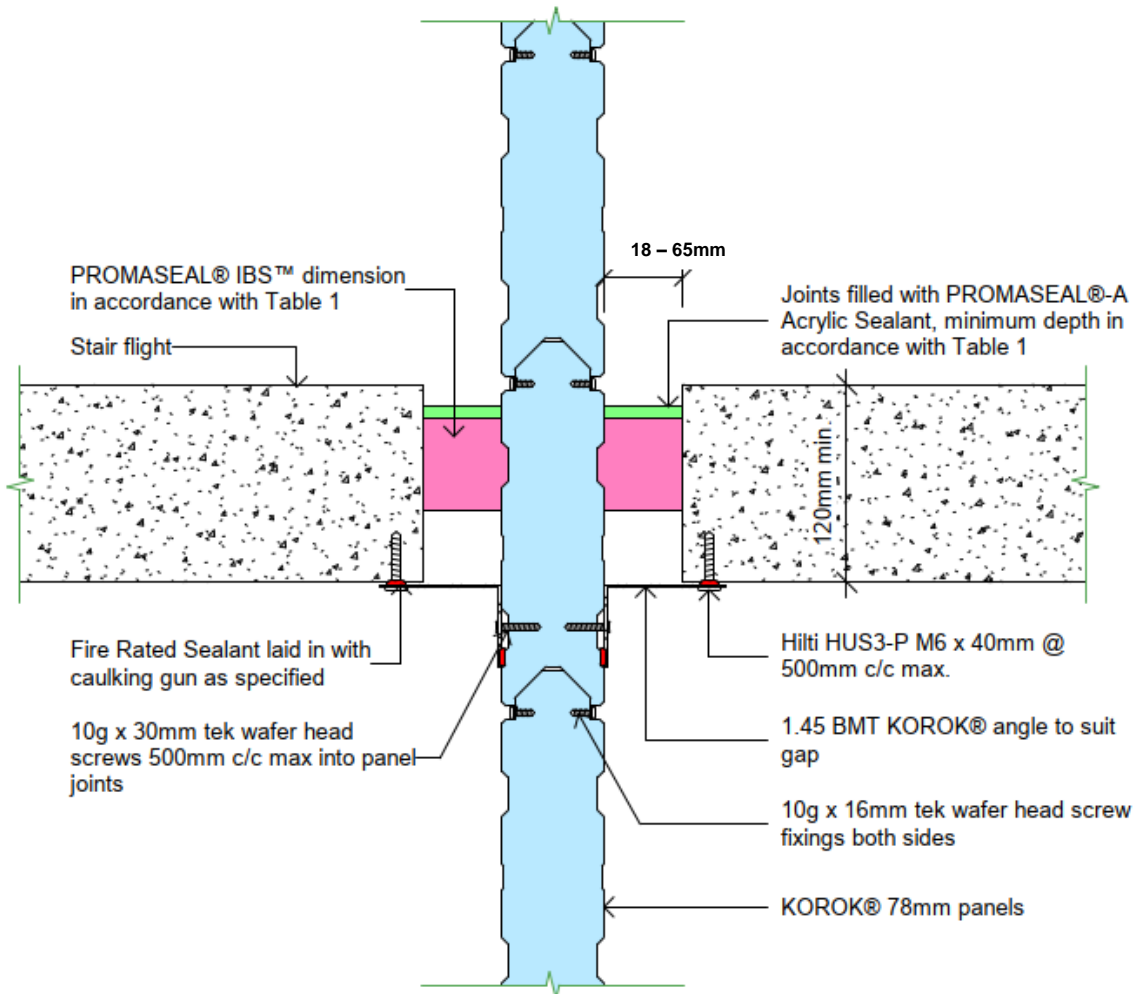

Figure 30 18 mm – 65 mm wide joint between KOROK® wall and stair stringer – protected with PROMASEAL® IBS™ strips and sealant (for applications requiring an FRL of - /60/60 only)

Table 7 Joint dimensions for PROMASEAL® IBS™ strips

Maximum joint width (mm)	Nominal IBS™ thickness (mm)	Minimum depth of non fire-rated sealant (mm)
18	22	9
30	38	12
35	38	12
54	60	18
65	80	20

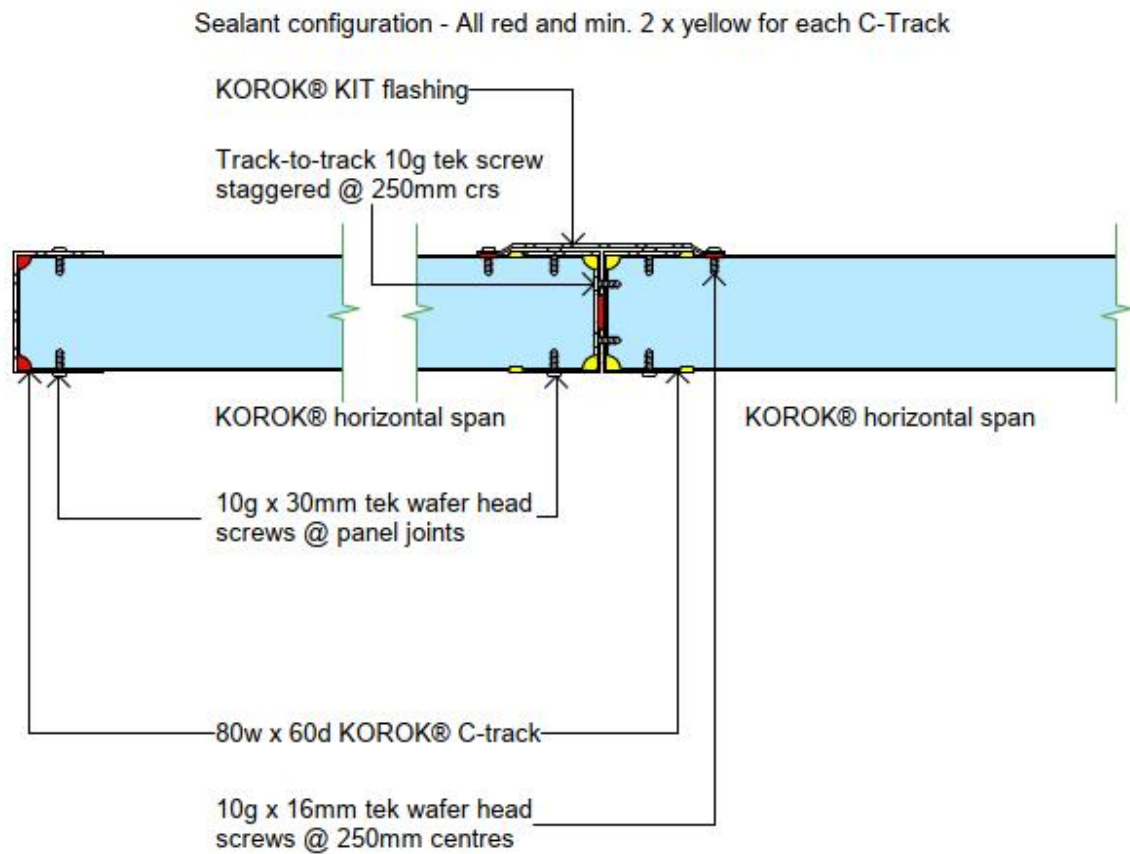

Figure 31 Back-to-back C-track connection for WT2C and WT2D – plan view (Detail 1 as denoted in Figure 7 and Figure 8)

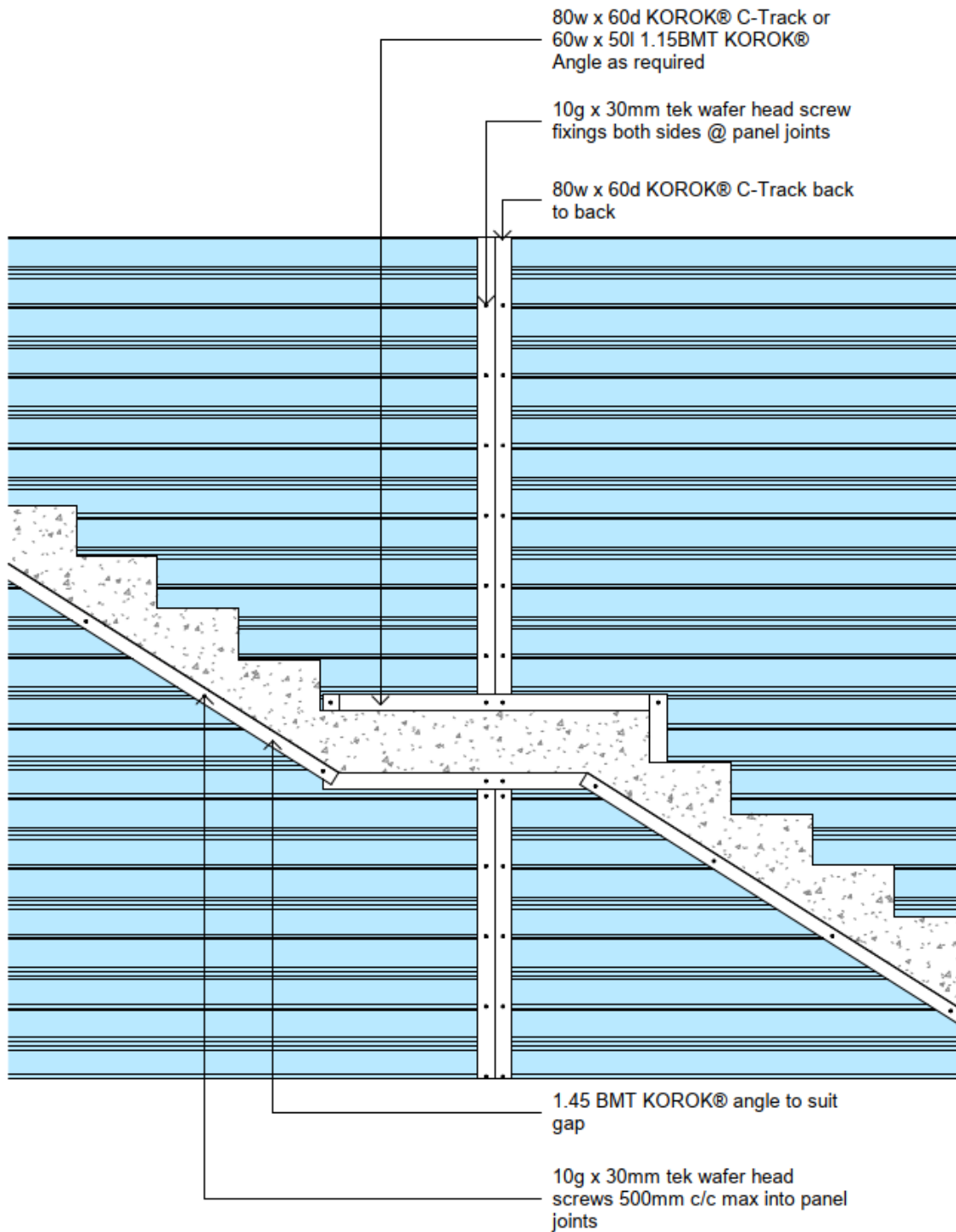

Figure 32 Mid-landing for WT2D – elevation (Detail 7 as denoted in Figure 8)

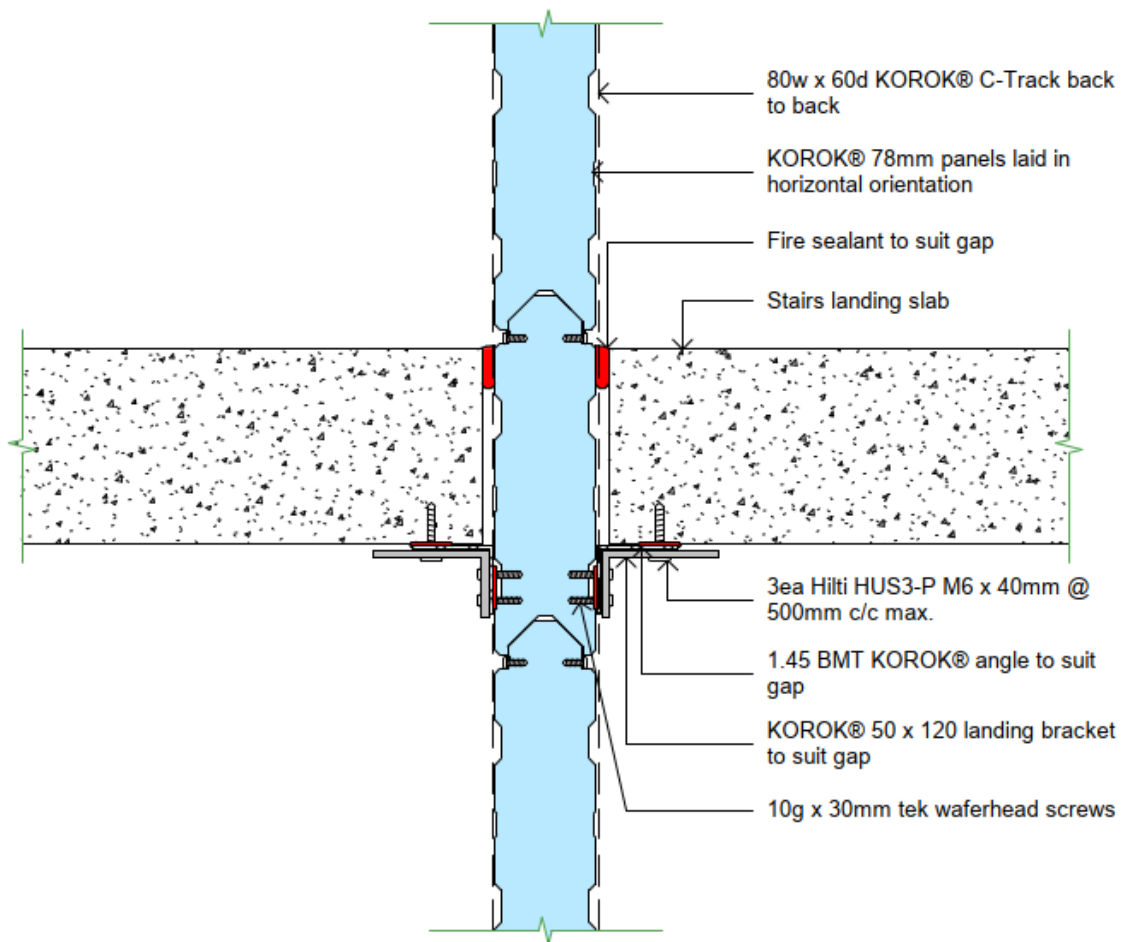

Figure 33 Mid-landing with KOROK® landing bracket – section view (Detail 8 as denoted in Figure 7)

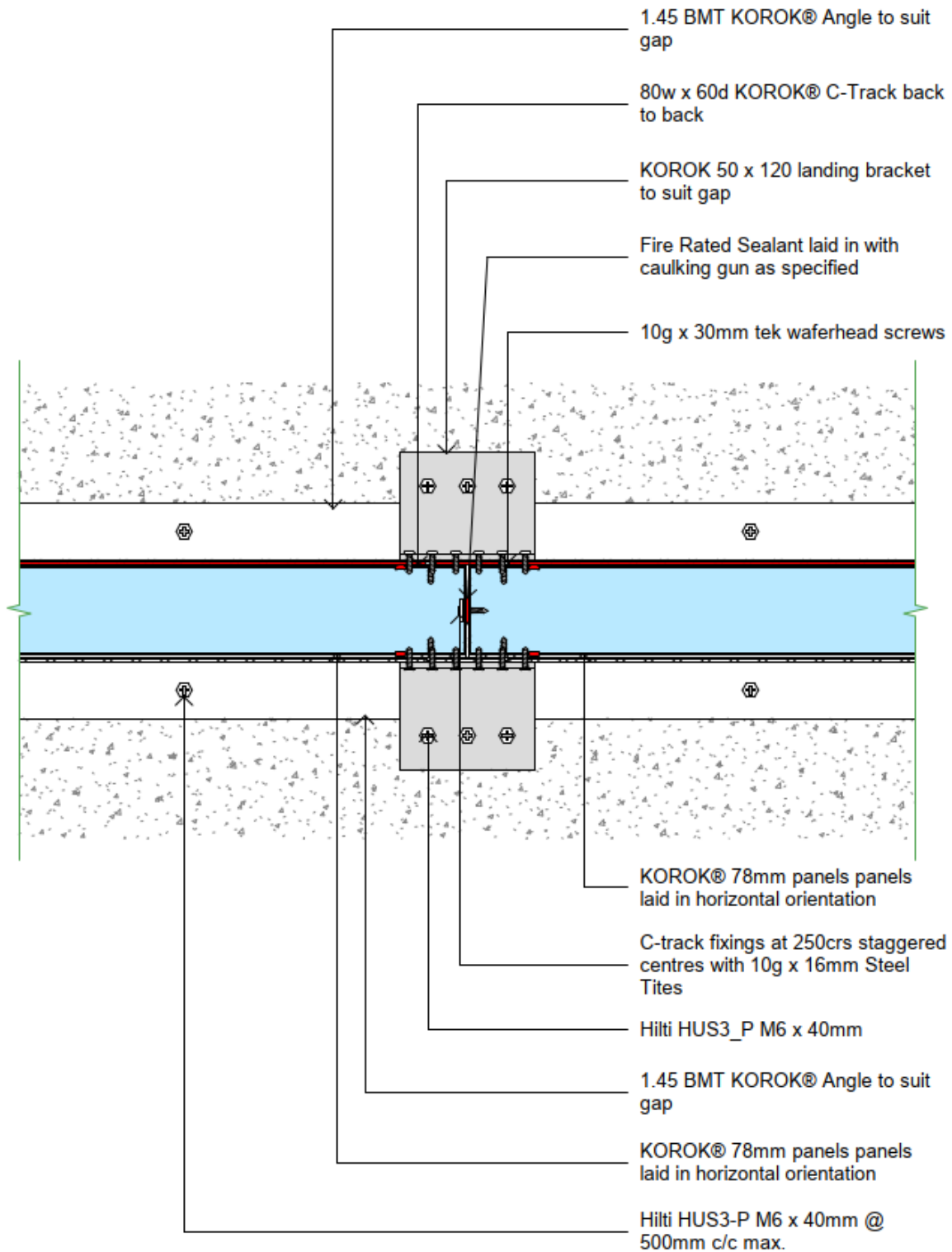

Figure 34 Mid-landing with KOROK® landing bracket – plan view (Detail 8 as denoted in Figure 7)

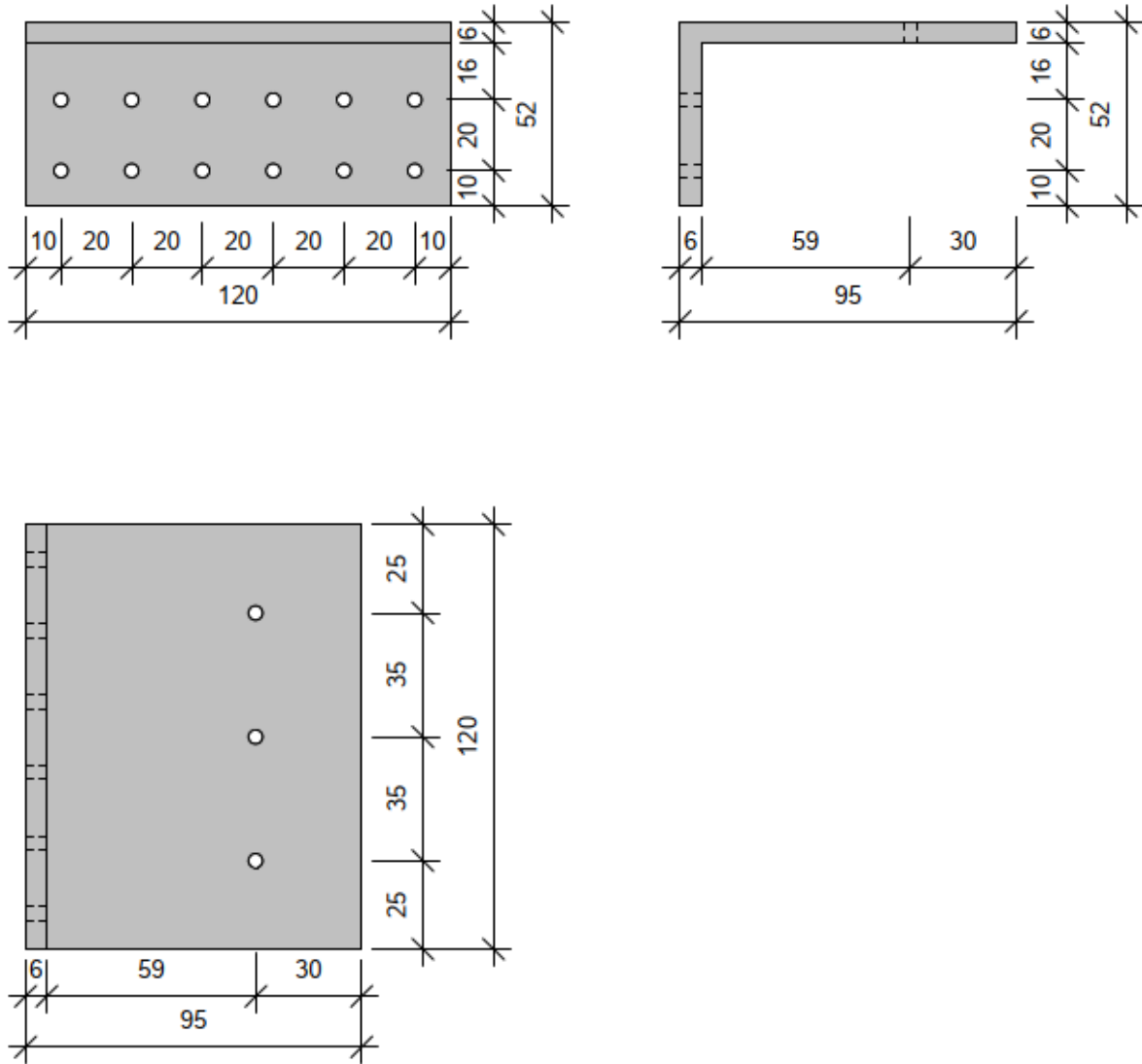

Figure 35 KOROK® 6 mm landing bracket for joint gaps of 0 mm – 30 mm – bracket dimensions

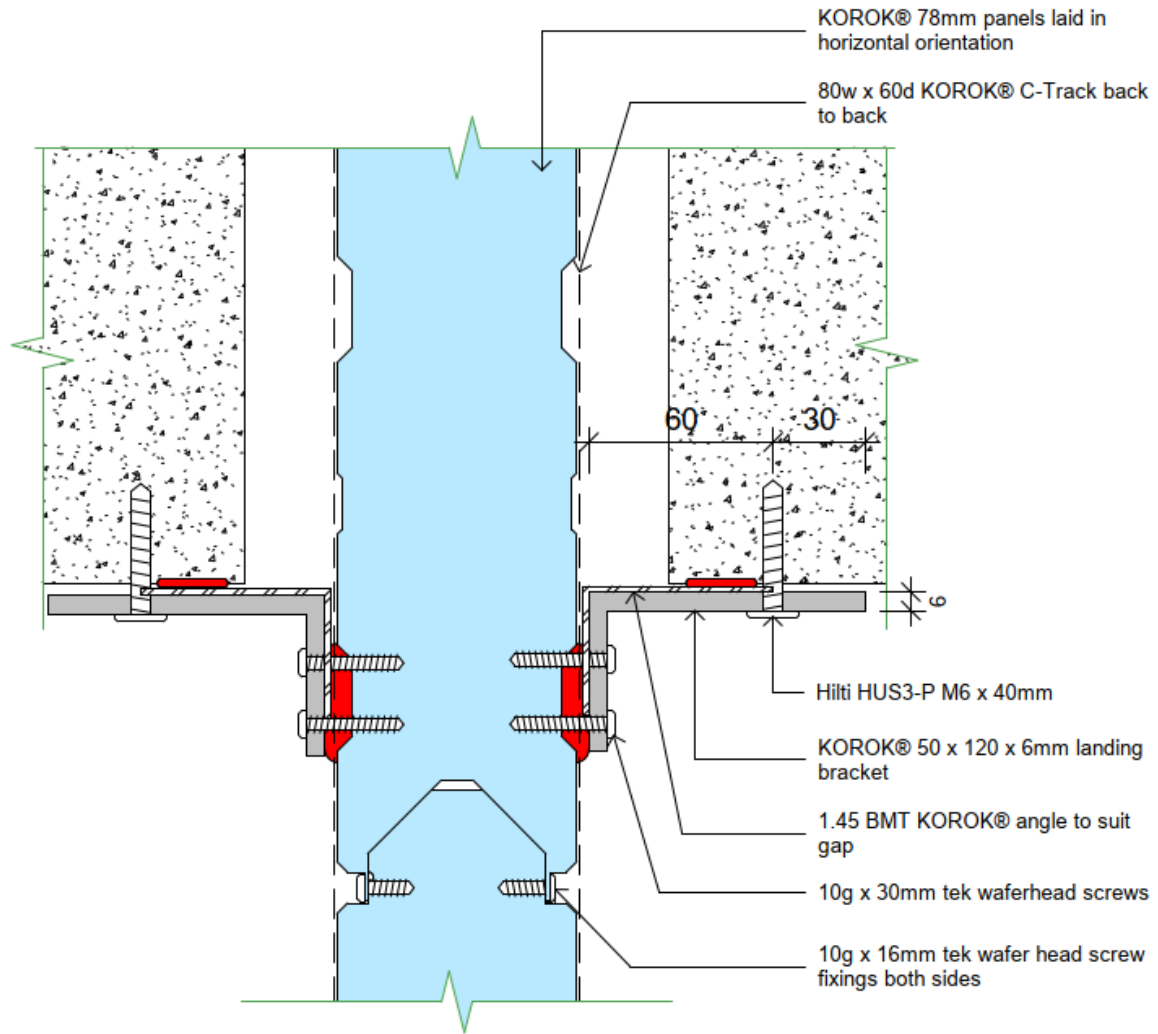

Figure 36 KOROK® 6 mm landing bracket for joint gaps of 0 mm – 30 mm – section view (fire sealing systems not shown here)

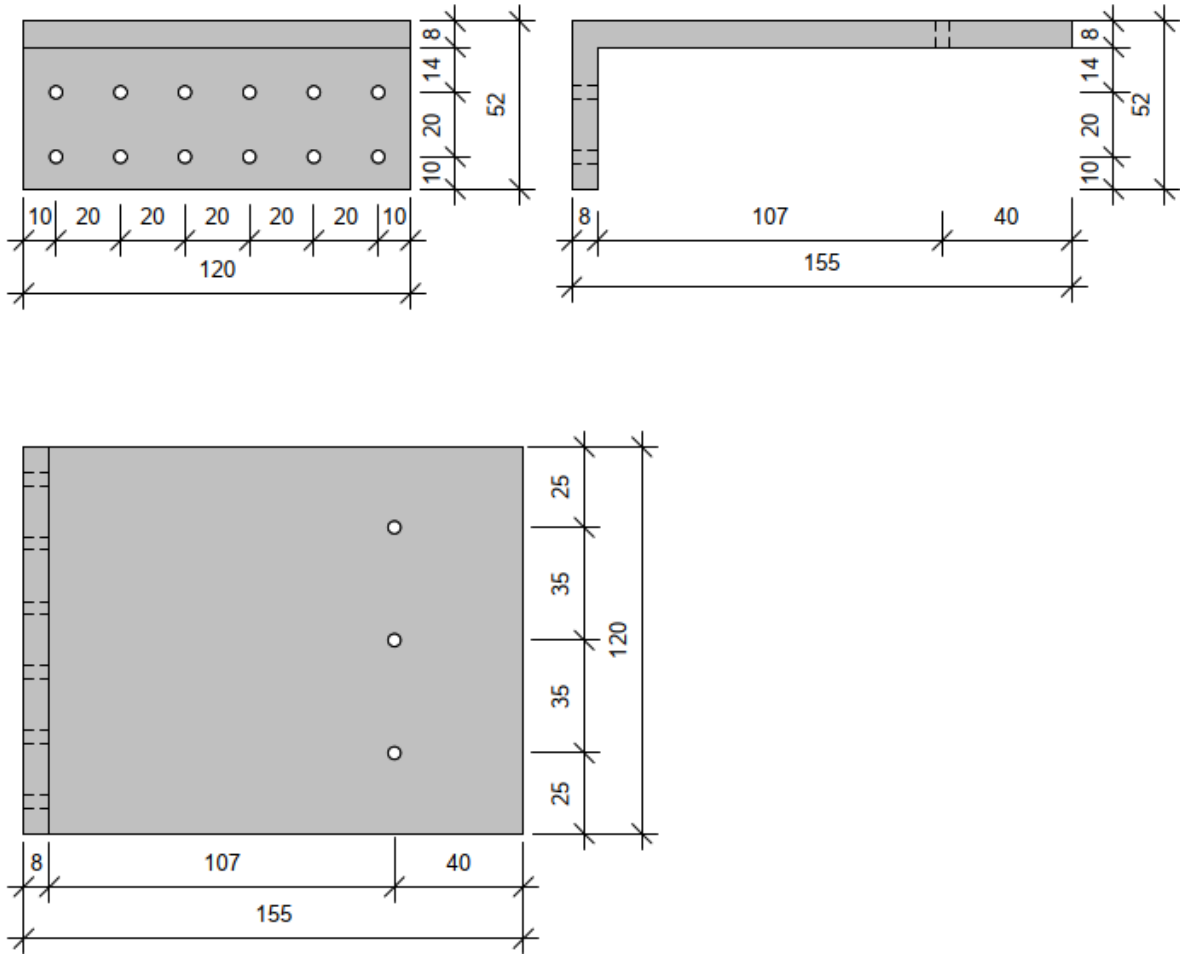

Figure 37 KOROK® 6 mm landing bracket for joint gaps of 30 mm – 80 mm – bracket dimensions

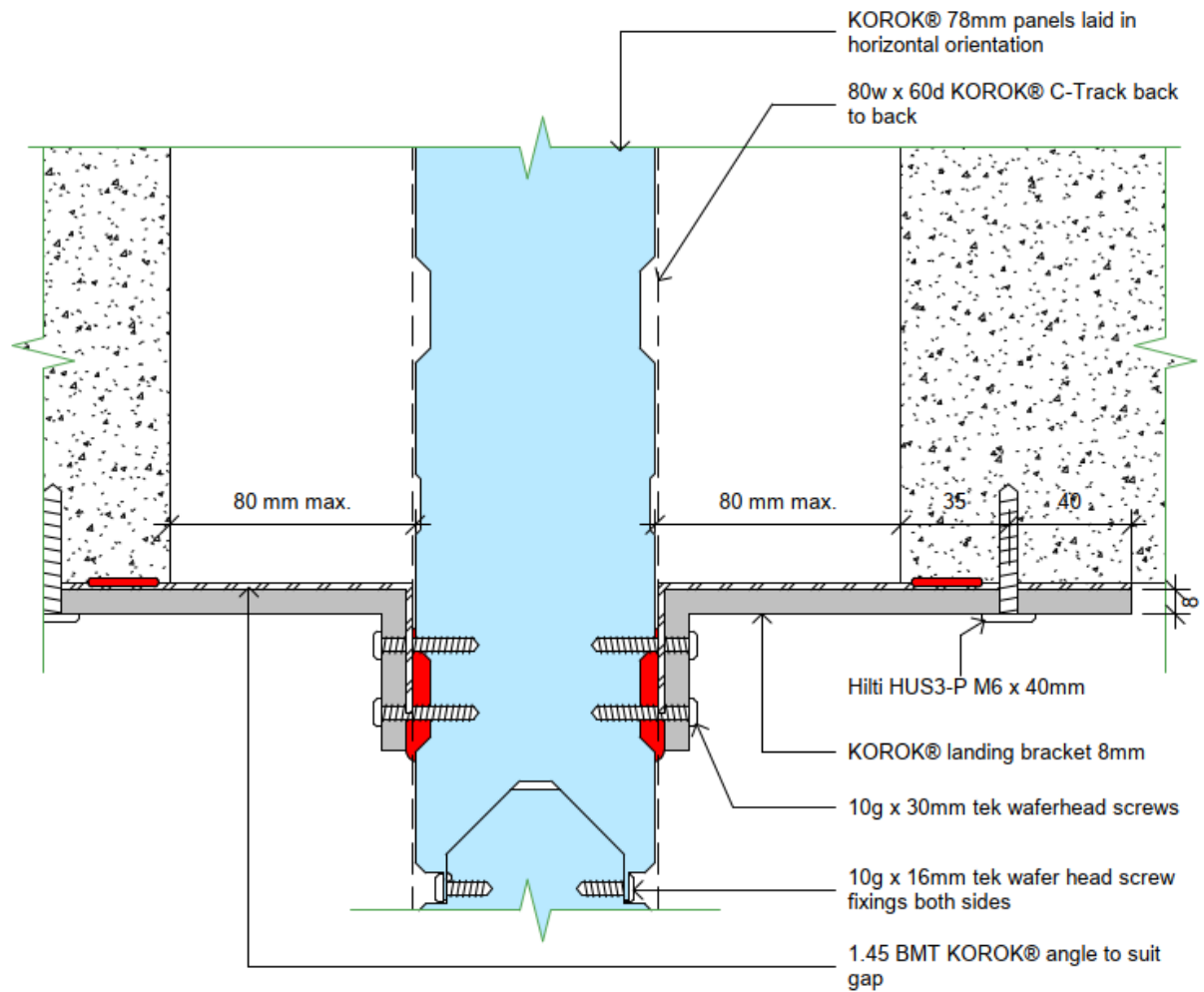

Figure 38 KOROK® 8 mm landing bracket for joint gaps of 30 mm – 80 mm – section view (fire sealing systems not shown here)

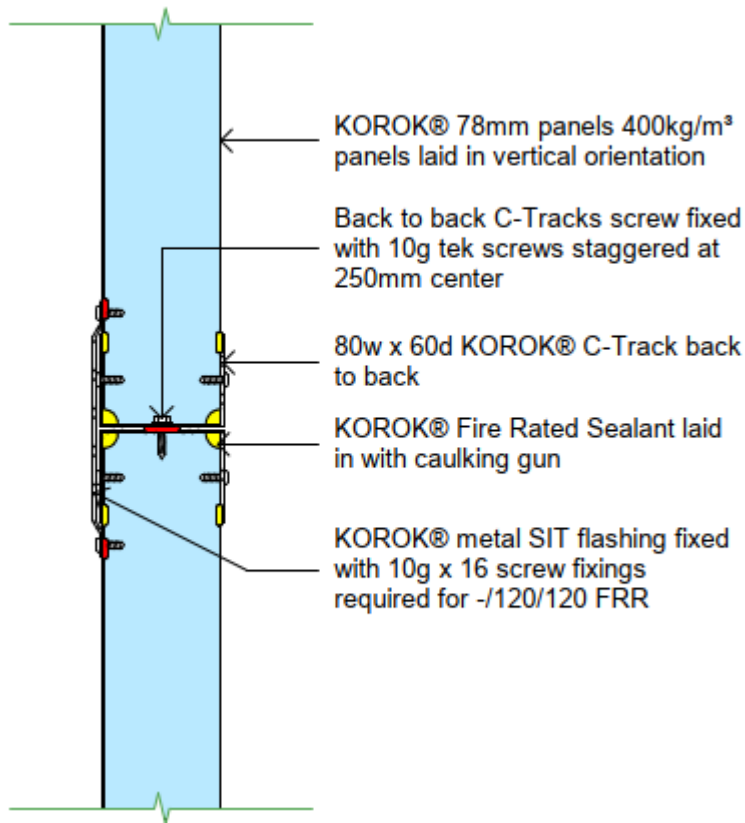

Figure 39 Back-to-back C-track connection for WT3A, WT3B and WT3C – section view (Detail 11 as denoted in Figure 9 to Figure 11)

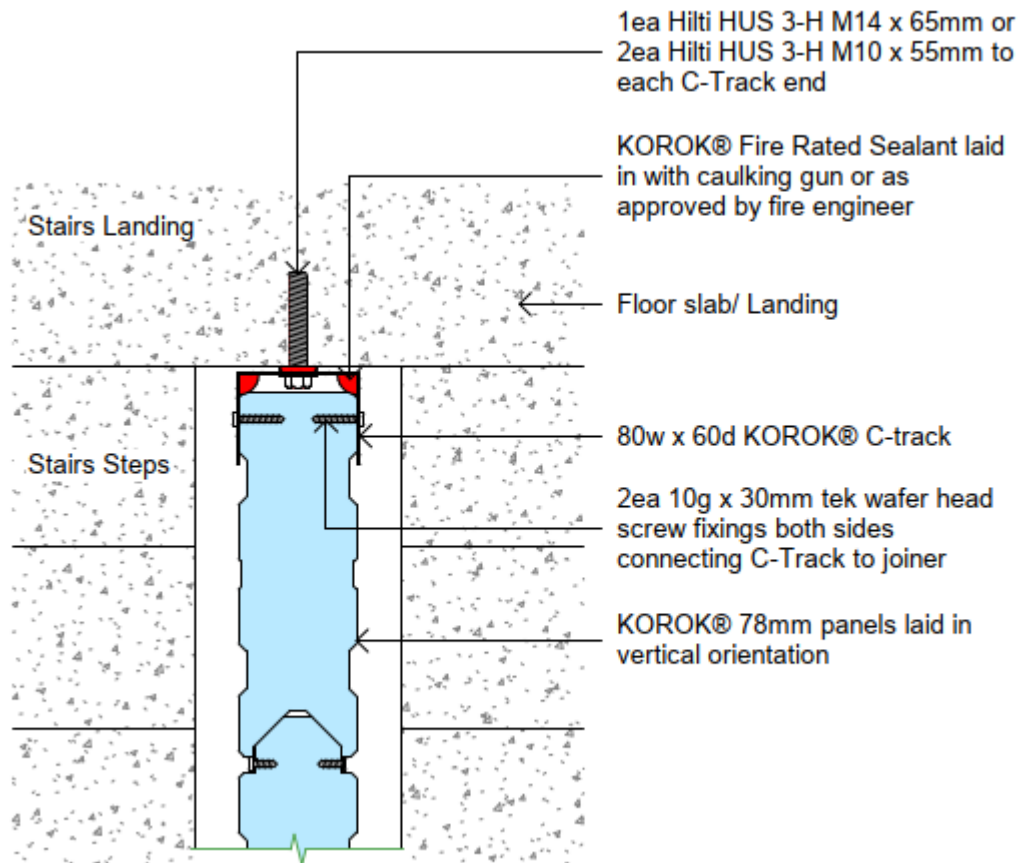

Figure 40 Connection between C-track and landings – elevation (Detail 9 as denoted in Figure 9 to Figure 11)

Sealant configuration - All red and min. 2 x yellow for each C-Track

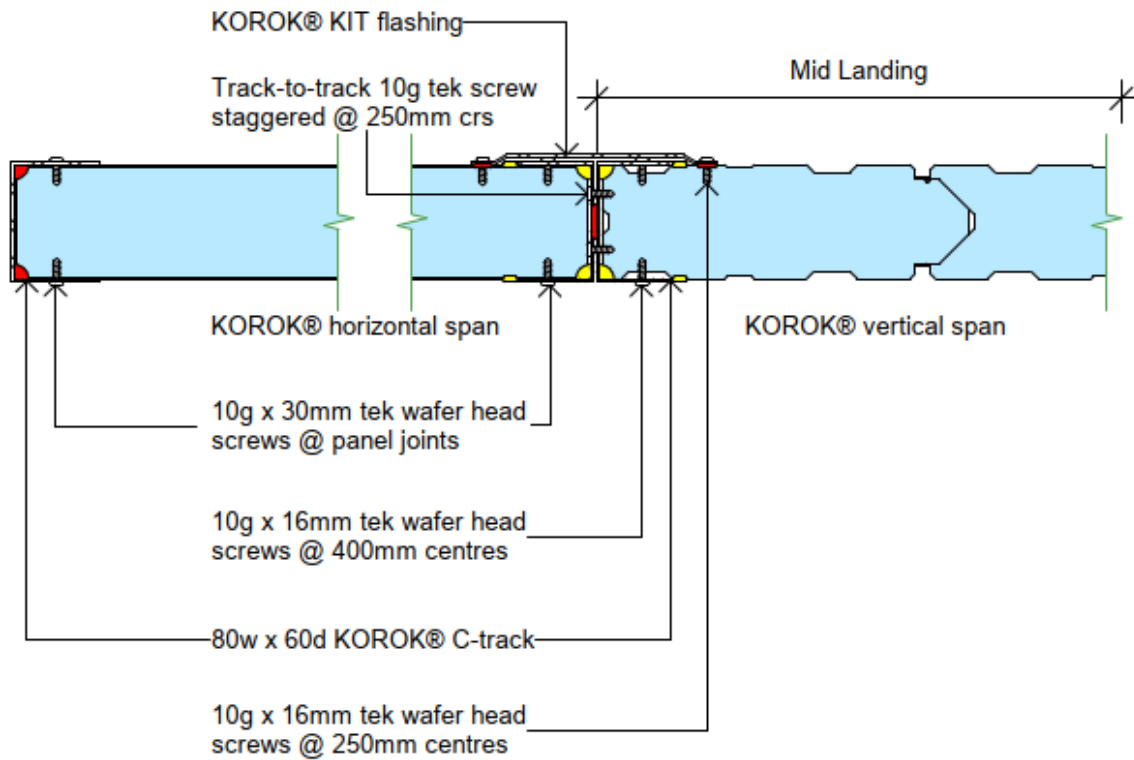

Figure 41 Back-to-back C-track connection for WT1A and WT1B – plan view (Detail 1 as denoted in Figure 12 and Figure 13)

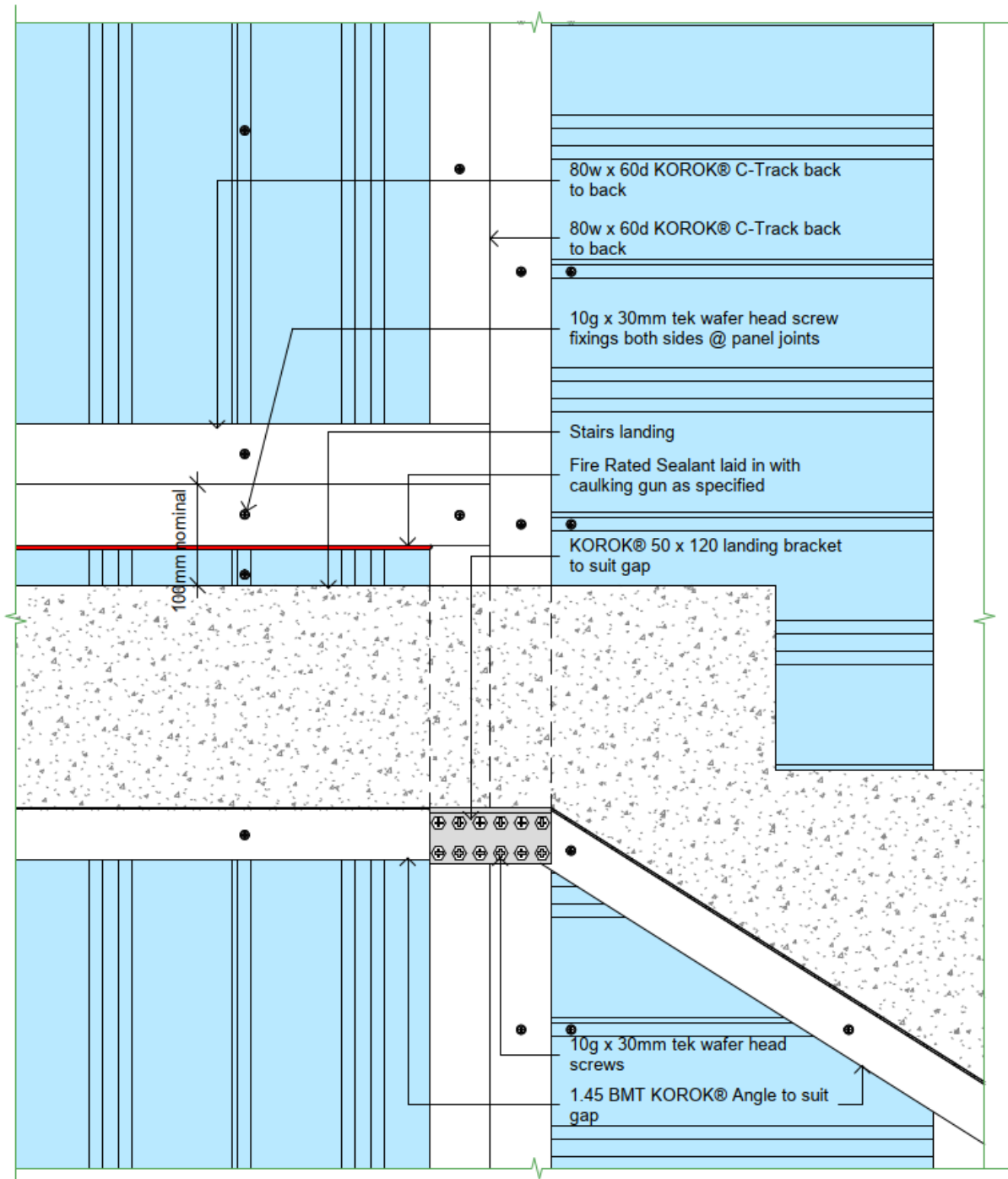
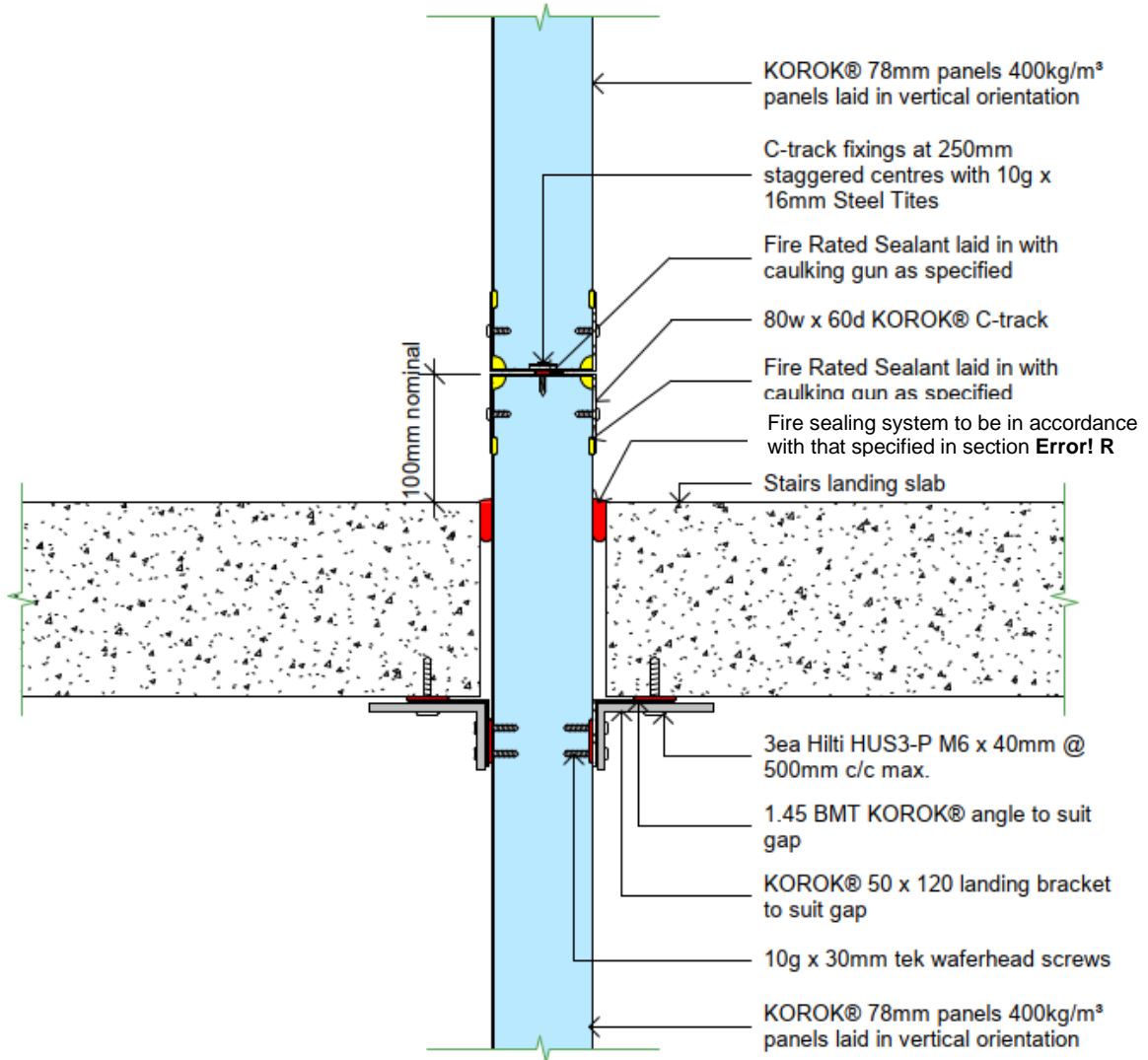
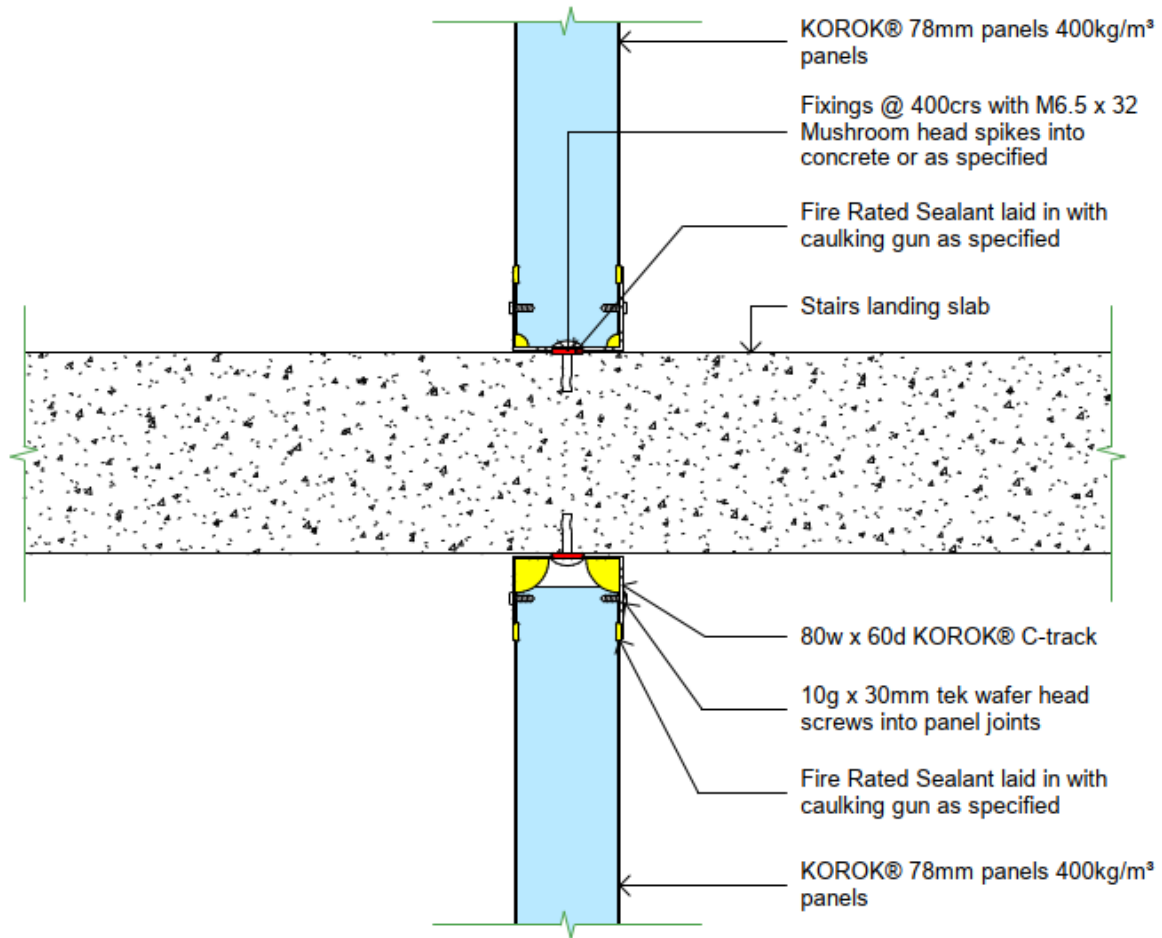

Figure 42 KOROK® landing bracket in WT1A – elevation (Detail 5 as denoted in Figure 12)



Sealant configuration - All red and min. 2 x yellow for each C-Track

Figure 43 KOROK® landing bracket in WT1A – section view (Detail 5 as denoted in Figure 12)



Sealant configuration - All red and min. 2 x yellow for each C-Track

Figure 44 Mid-landing which is continuous across WT1B KOROK® wall – section view (Detail 4 as denoted in Figure 13)

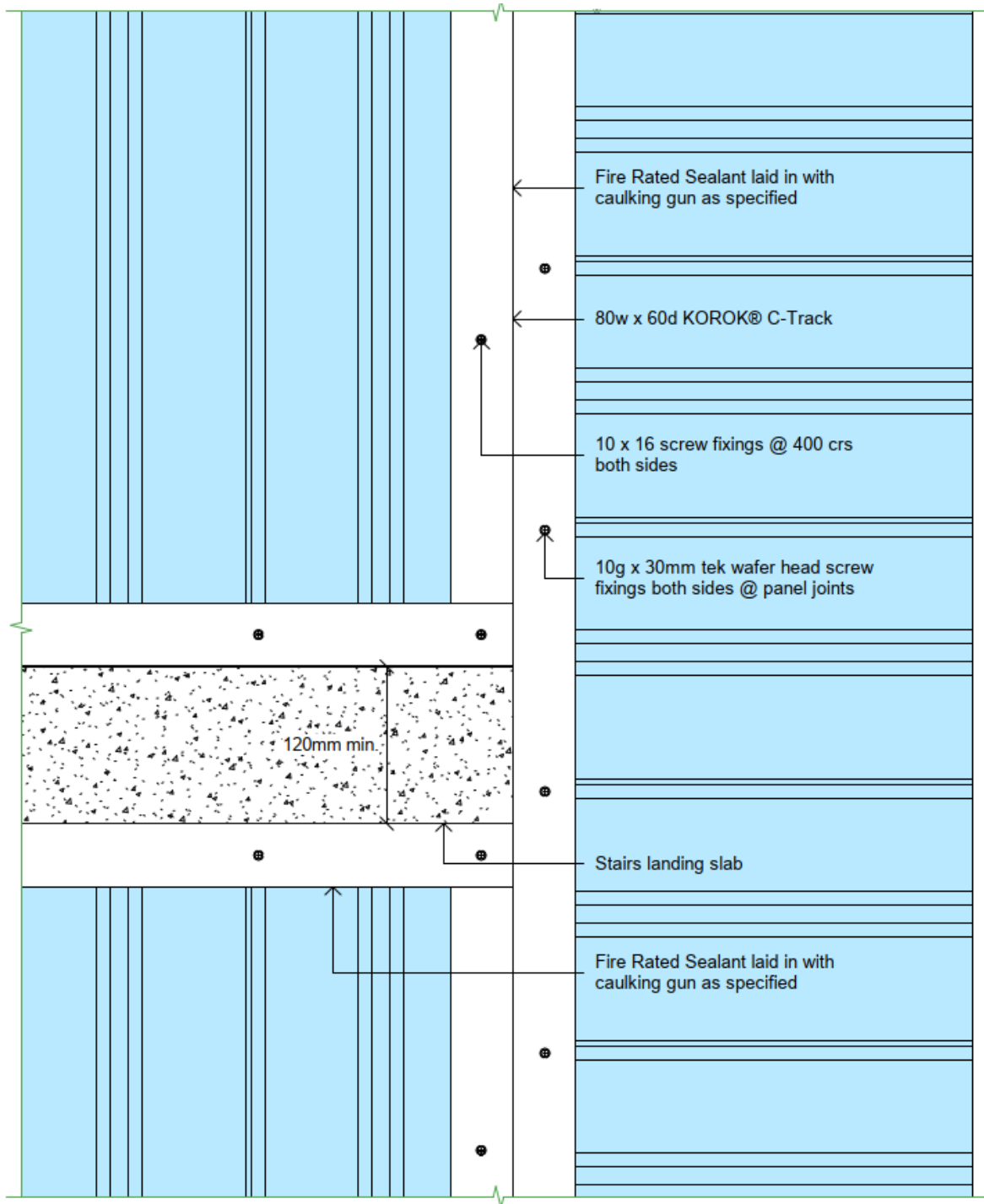

Figure 45 Mid-landing which is continuous across WT1B KOROK® wall – elevation (Detail 4 as denoted in Figure 13)

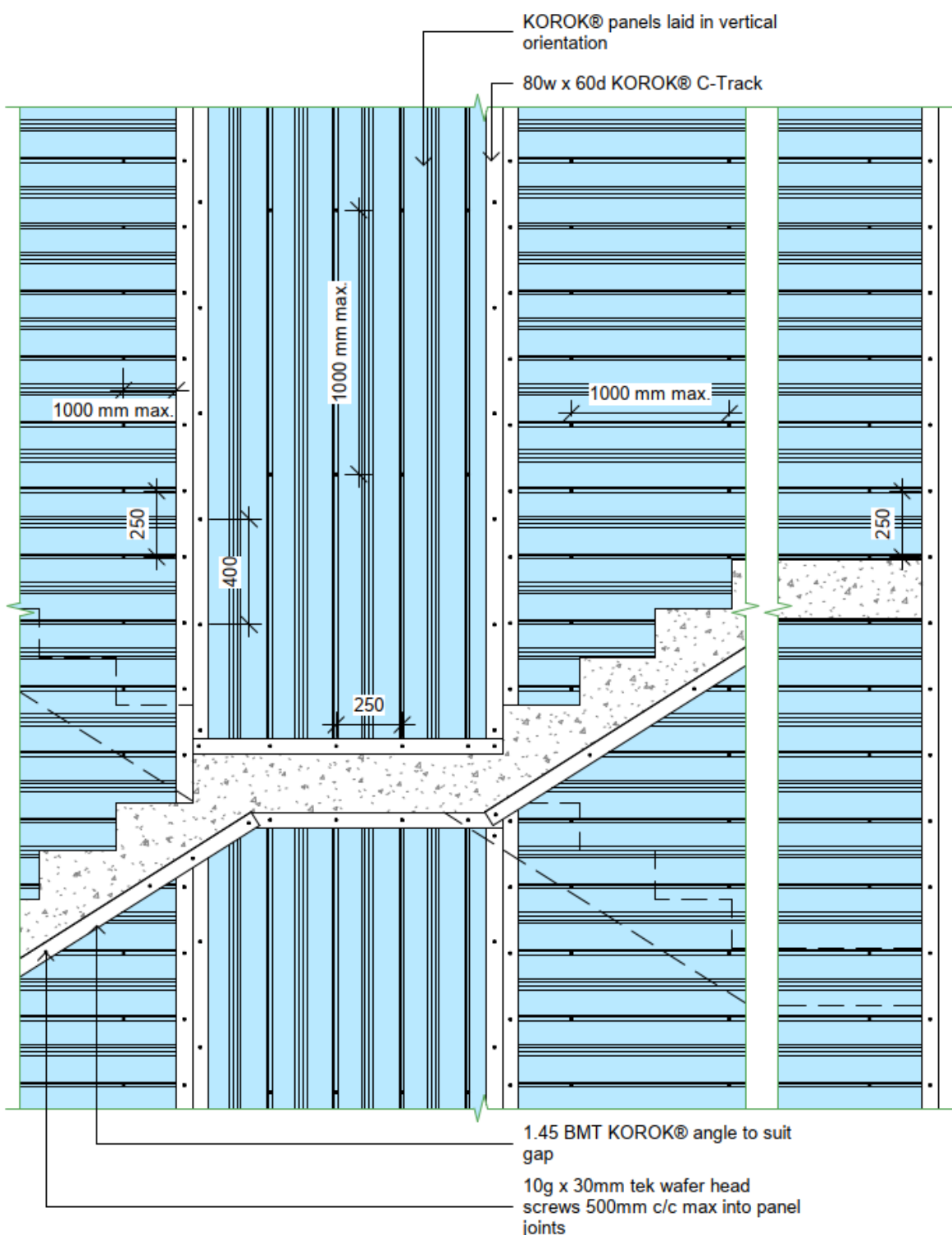

Figure 46 Mid-landing which is continuous across WT1B KOROK® wall – elevation (Detail 4 as denoted in Figure 13)

5. Assessment outcome

Details of the assessment and discussion are only available in the referenced main assessment report. It has been concluded that the proposed systems together with the described variations are expected to achieve the fire resistance levels (FRLs) as stated below in accordance with AS 1530.4 2014. A summary of the assessment outcome is outlined in Table 8.

Table 8 Assessment outcome

Wall type	Variations	FRL*
WT2	<ul style="list-style-type: none"> Single wall consisting of horizontally orientated KOROK® panels connected to C-tracks on the vertical edges. C-tracks are fixed at the top and bottom to concrete landings with M14 or 2 × M10 anchors at each landing. Wall is connected to the steel angle beneath the concrete stair stringers (1.45 mm BMT) on both sides with 10g screws at maximum 500 mm c/c spacing horizontally. The wall system consists of a mid-landing which is discontinuous between the scissor stairs or the wall system may not have a mid-landing. Reference Figure 5. 	<ul style="list-style-type: none"> For -/60/60 – the maximum horizontal span is 5.5 m and the slab-to-slab height is maximum 4 m with 1.15 mm BMT side C-tracks. For -/120/120 – the maximum horizontal span is 5 m and the slab-to-slab height is maximum 4 m with 1.45 mm BMT side C-tracks.
WT2A	<ul style="list-style-type: none"> Same as WT2 but with the mid-landing continuous between the two opposite scissor stairs. Reference Figure 6. 	
WT2C	<ul style="list-style-type: none"> Dual-stack wall system consisting of two wall segments made of horizontally orientated KOROK® panels. The horizontally orientated wall sections are connected via back-to-back C-tracks. The connection point between back-to-back C-tracks must be protected with a 0.7 mm BMT galvanised steel flashing on the unexposed side. For a proposed FRL of -/60/60 – the maximum horizontal span of each wall is 5.5 m and the slab-to-slab height is maximum 4 m with 1.15 mm BMT side C-tracks. For a proposed FRL of -/120/120 – the maximum horizontal span of each wall is 5 m and the slab-to-slab height is maximum 4 m with 1.45 mm BMT side C-tracks. C-tracks are fixed at the top and bottom to concrete landings with M14 or 2 × M10 anchors at each landing including mid-landings. 	<ul style="list-style-type: none"> For -/60/60 – the maximum horizontal span of each wall section is 5.5 m and the slab-to-slab height is maximum 4 m with 1.15 mm BMT side C-tracks. For -/120/120 – the maximum horizontal span of each wall section is 5 m and the slab-to-slab height is maximum 4 m with 1.45 mm BMT side C-tracks.

Wall type	Variations	FRL*
	<ul style="list-style-type: none"> Wall is connected to the steel angle beneath the concrete stair stringers (1.45 mm BMT) on both sides with 10g screws at maximum 500 mm c/c spacing horizontally. Consists of a mid-landing which is discontinuous between the scissor stairs or short and long leg support brackets are used instead of a mid-landing, where required. Reference Figure 7. 	
WT2D	<ul style="list-style-type: none"> Same as WT2C but with the mid-landing continuous between the two opposite scissor stairs. Reference Figure 8. 	
WT3A	<ul style="list-style-type: none"> Same as WT3C and WT3B except that a fire protected structural steel or concrete beam is installed to support the topmost level only. Reference Figure 9. 	<ul style="list-style-type: none"> -/120/120 The maximum total height of the wall can be unlimited provided that the maximum height of each panel spanning between back-to-back tracks is 4 m and is connected to the stair stringer angle (1.45 mm BMT) with minimum one 10 g screw on each side of the wall (therefore minimum two screws per panel) at 250 mm c/c.
WT3B	<ul style="list-style-type: none"> Same as WT3C but with the mid-landing continuous between the two opposite scissor stairs. The horizontal span (X) and maximum total wall height (Y_{max}) can be unlimited provided that each panel extends up to a maximum height of 4 m between back-to-back tracks and is connected to the stair stringer angle (1.45 mm BMT) with minimum one 10 g screw on each side of the wall (therefore minimum two screws per panel). The maximum spacing between 10 g stair stringer angle screws to be 250 mm. At the continuous mid-landing, the self-weight of the vertical panels must be supported by the mid-landing. Reference Figure 10. 	
WT3C	<ul style="list-style-type: none"> Single wall, of unlimited height, consisting of vertically orientated KOROK® panels connected to C-tracks on the vertical edges supported by the connection to the bottom steel angle of the stair stringers. Each wall segment is divided by horizontal back-to-back C-tracks which are not expected to transfer any loads or provide any structural stiffness. The connection point between back-to-back C-tracks must be protected with a 0.7 mm BMT galvanised steel flashing on the unexposed side. The horizontal span (X) and maximum total wall height (Y_{max}) can be unlimited provided that each panel extends up to a maximum height of 4 m between back-to-back tracks and is connected to the stair stringer angle (1.45 mm BMT) 	

Wall type	Variations	FRL*
	<p>with minimum one 10 g screw on each side of the wall (therefore minimum two screws per panel).</p> <ul style="list-style-type: none"> The maximum spacing between 10 g stair stringer angle screws to be 250 mm. Reference Figure 11. 	
WT1A	<ul style="list-style-type: none"> Dual-stack wall system consisting of a wall segment made of vertically orientated KOROK® panels between two wall segments with horizontally orientated KOROK® panels. The horizontal and vertical orientated wall sections are connected via back-to-back C-tracks. The connection point between back-to-back C-tracks must be protected with a 0.7 mm BMT galvanised steel flashing on the unexposed side. The vertical wall – at mid-width of the dual-stack wall system – is supported by the stair stringer angle at the mid-landing or by KOROK® support brackets. For a proposed FRL of -/60/60 – the maximum horizontal span of each horizontal wall segment is 5.5 m. The slab-to-slab height is maximum 4 m with 1.15 mm BMT side C-tracks. For a proposed FRL of -/120/120 – the maximum horizontal span of each horizontal wall segment is 5 m. The slab-to-slab height is maximum 4 m with 1.45 mm BMT side C-tracks. The minimum horizontal width of the vertical wall segment must be 500 mm (two panels orientated vertically). Each panel can extend up to a maximum height of 4 m between back-to-back tracks and must be connected to the stair stringer angle (1.45 mm BMT) with minimum one 10 g screw on each side of the wall (therefore minimum two screws per panel). The maximum spacing between 10 g stair stringer angle screws to be 250 mm. Reference Figure 12. 	<ul style="list-style-type: none"> For -/60/60 – the maximum horizontal span of each horizontal wall segment is 5.5 m. The slab-to-slab height is maximum 4 m with 1.15 mm BMT side C-tracks. For -/120/120 – the maximum horizontal span of each horizontal wall segment is 5 m. The slab-to-slab height is maximum 4 m with 1.45 mm BMT side C-tracks. For both -/60/60 and -/120/120 FRLs, the minimum horizontal width of the vertical wall segment must be 500 mm (two panels orientated vertically). Each panel can extend up to a maximum height of 4 m between back-to-back tracks and must be connected to the stair stringer angle (1.45 mm BMT) with minimum one 10 g screw on each side of the wall (therefore minimum two screws per panel).
WT1B	<ul style="list-style-type: none"> Same as WT1A but with the mid-landing continuous between the two opposite scissor stairs. At the continuous mid-landing, the self-weight of the vertical panels must be supported by the mid-landing. Reference Figure 13. 	
All walls	<ul style="list-style-type: none"> The fire resistance performance of the proposed KOROK® walls in the vertical plane is provided at the wall-to-stair stringer joint at the boundaries of the KOROK® wall section highlighted in Figure 4. 	Integrity and insulation performances expected to be maintained for up to 120 minutes.

Wall type	Variations	FRL*
	<ul style="list-style-type: none"> The wall-to-stair stringer joint detail varies based on the width of the joint between the KOROK® wall and the concrete stairs. The various joint configurations are shown in Figure 24 to Figure 30. 	
<p>Note – For walls WT2A, WT2D, WT3B, WT3A and WT1B where the mid-landing of the scissor stairs breaches the KOROK® wall, the use of the head and base details shown in Figure 19 will reduce the assessed FRLs to -/120/60 or -/60/30. Alternatively, the use of the head and base details shown in Figure 20 will maintain the assessed FRLs.</p>		

6. Validity

Warringtonfire Australia does not endorse the tested or assessed products and systems in any way. The conclusions of the referenced assessment may be used to directly assess fire resistance, but it should be recognised that a single test method will not provide a full assessment of fire resistance under all conditions.

Due to the nature of fire testing and the consequent difficulty in quantifying the uncertainty of measurement, it is not possible to provide a stated degree of accuracy. The inherent variability in test procedures, materials and methods of construction, and installation may lead to variations in performance between elements of similar construction.

The referenced assessment is based on test data, information and experience available at the time of preparation. If contradictory evidence becomes available to the assessing authority, the assessment will be unconditionally withdrawn and the report sponsor will be notified in writing. Similarly, the assessment should be re-evaluated, if the assessed construction is subsequently tested since actual test data is deemed to take precedence.

The procedures for the conduct of tests and the assessment of test results are subject to constant review and improvement. The sponsor is therefore recommended that the referenced assessment report be reviewed on, or before, the stated expiry date.

The referenced assessment represents our opinion about the performance of the proposed systems that is expected to be demonstrated when subjected to test conditions in accordance with AS 1530.4:2014, based on the evidence referred to in the referenced assessment report.

The referenced assessment is provided to KOROK Building Systems NZ Ltd for their own specific purposes. The referenced assessment report may be used as evidence of suitability in accordance with the requirements of the relevant National Construction Code. Building certifiers and other third parties must determine the suitability of the systems described in the referenced assessment report for a specific installation.

Global locations



Warringtonfire Australia Pty Ltd
ABN 81 050 241 524

Perth

Suite 4.01, 256 Adelaide Terrace
Perth WA 6000
Australia
T: +61 8 9382 3844

Canberra

Unit 10, 71 Leichhardt Street
Kingston ACT 2604
Australia
T: +61 2 6260 8488

Melbourne

Level 4, 152 Elizabeth Street
Melbourne Vic 3000
Australia
T: +61 3 9767 1000

Sydney

Suite 802, Level 8, 383 Kent Street
Sydney NSW 2000
Australia
T: +61 2 9211 4333

Brisbane

Suite B, Level 6, 133 Mary Street
Brisbane Qld 4000
Australia
T: +61 7 3238 1700

Melbourne – NATA accredited laboratory

409-411 Hammond Road
Dandenong South Vic 3175
Australia
T: +61 3 9767 1000