

SEPT 2018



**SEISMIC
BRACING GUIDE
PARTITIONS & CEILINGS**

**NEW ZEALAND
FOURTH EDITION**

TRACKLOK®

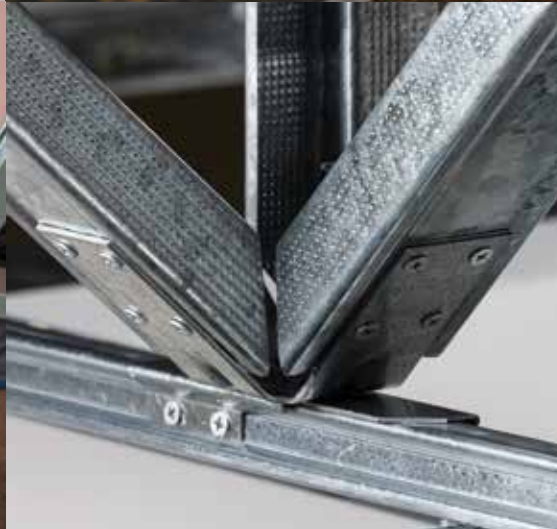

CONTENTS/

About us	2
TRACKLOK® Range	3
Features and Benefits	4
Install Instructions & Plenum Guidance	5
TRACKLOK® Plan & Elevations	6
Seismic Zone Chart	7
Setout Chart One	8
Setout Chart Two	9
Setout Chart Three	10
GAPLOK	11
TRACKLOK® FLAT	13
Features and Benefits	14
Install Instructions	15
TRACKLOK® FLAT Plan & Elevations	15
TRACKLOK® FLAT Partition Elevations	16
Top Connections	
Concrete Connection Detail	18
Comflor Connection Detail	19
Parallel Steel Connection Detail	20
Perpendicular Steel Connection Detail	21
Parallel Timber Connection Detail	22
Perpendicular Timber Connection Detail	23
Bridging and Bulkheads	
Parallel Bridge Detail	24
Perpendicular Bridge Detail	25
Parallel & Perpendicular Bridge Notes	26
Service Bridge Detail	27
Service Bridge Notes	28
Bulkhead Bracing Detail	29
Bulkhead Bracing Notes	30
GRIDLOK®	31
GRIDLOK® Range	32
Features and Benefits	33
Install Instructions & Plenum Guidance	34
GRIDLOK® Isometric	35
GRIDLOK® Peak Form Isometric	36
GRIDLOK® Kwikloc Isometric	37
GRIDLOK® Top Cross Rail (TCR) Isometric	38
GRIDLOK® C Channel Isometric	39
GRIDLOK® U-Profile Isometric	40
Accessories	
BC45 Connectors	42
BC90 Connectors	43
Appendix – TRACKLOK®	44
Appendix – GRIDLOK®	46
Terms & Conditions	48

ABOUT US/

TRACKLOK® LTD BELIEVES THE WAY TO "BUILD IT BETTER" IS THROUGH A SYSTEMISED APPROACH, WHILE PROVIDING A BASE LINE FOR SPECIFIC DESIGN.

The intent of this document is to provide guidance for the bracing of non-structural walls and ceilings, while providing engineers with a first principles document enabling efficient and consistent specific designs, where required.

This range of pre-engineered, off the shelf solutions enables architects, designers, structural engineers, construction companies and installers to mitigate the risk of non-structural failure in commercial buildings.

TRACKLOK® Ltd provides bracing options to take the guesswork and liability out of securing non-structural walls and ceilings. Both the TRACKLOK® and GRIDLOK® range of connections have been designed to comply with building code requirements and ceiling manufacturers warranties.

The TRACKLOK® system for walls and the GRIDLOK® system for ceilings are perfect examples of applying logic, innovation and best practice to mitigate risk and improve building resilience.

Interior fit out is a complicated, multi trade discipline, which requires cost and time efficient solutions to standard practices. The use of these products allows wall and ceiling systems to perform independently as designed.

The testing regime has been thorough, extensive and has utilised the best minds in the engineering, architectural and academic world. These results have been accredited, peer reviewed and ultimately tested in real world seismic events.

TRACKLOK® Ltd continues to help the construction industry "build it better".

TRACKLOK® Ltd works with like-minded industry leaders worldwide. We work with industry organisations, regulators and governments to ensure design through to build consistency and compliance.

TRACKLOK RANGE/



TRACKLOK® - TRACKLOK® for new builds, allows you to connect directly through the partition head, separating wall from ceiling. Tested to provide structural and seismic performance for internal non-structural walls and glazing lines. Steel head track must be a minimum of .75 BMT, while aluminium head track must have a minimum material thickness of 1.3mm. Utilises steel stud for bracing stock. Using 10-gauge wafer tek screws to attach bracing stock to the unit and top connectors. Set out charts provide clear guidance for placement. Utilised in IL2, IL3 and IL4 buildings. **STOCK CODE: SPT-10**



TRACKLOK® RETRO - Bringing an existing fit out up to seismic code, adding value to your clients existing fit out, or create time efficiencies by bracing after lining. TRACKLOK® RETRO is an effective way to retroactively attach to the partition head using 10-gauge wafer tek screws. Steel head track must be a minimum of .75 BMT, while aluminium head track must have a minimum material thickness of 1.3mm. Utilises steel stud for bracing stock. Using 10-gauge wafer tek screws to attach bracing stock to the unit and top connectors. Disengage walls and ceilings by using TRACKLOK® RETRO. Set out charts provide clear guidance for placement. Utilised in IL2, IL3 and IL4 buildings. **STOCK CODE: SPT-10R**



TRACKLOK® TIMBA - Timber framed walls and timber top plates present a unique bracing challenge. TRACKLOK® TIMBA is a uniquely designed solution, allowing the appropriate bracing while ensuring maximum connection to timber using minimum 10-gauge 35mm wood screws. Timber top plate must be minimum 90 x 45mm S8 Radiata Pine or Douglas Fir. Locator notch provides perfect placement every time. Utilises steel stud for bracing stock. Using 10-gauge wafer tek screws to attach bracing stock to the unit and top connectors. Set out charts provide clear guidance for placement. Utilised in IL2, IL3 and IL4 buildings. **STOCK CODE: SPT-10T**



TRACKLOK® VERT - Service clashes are inevitable and although the TRACKLOK® range provides flexibility with bracing angles from 30° to 60° there will always be some situations where this is not enough. TRACKLOK® VERT gives the installer a tool to use a vertical brace on one arm allowing for the ultimate in clash avoidance. Steel head track must be a minimum of .75 BMT, while aluminium head track must have a minimum material thickness of 1.3mm. Utilises steel stud for bracing stock. Using 10-gauge wafer tek screws to attach bracing stock to the unit and top connectors. Also, available with RETRO and TIMBA bases. Set out charts provide clear guidance for placement. Utilised in IL2, IL3 and IL4 buildings. **STOCK CODE: SPT-10V**

FEATURES AND BENEFITS/

- All products have been tested with steel and aluminium head track to ensure compatibility.
- Steel head track must be a minimum of .75 BMT, while aluminium head track must have a minimum material thickness of 1.3mm.
- Full wall system, quasi static testing provides specifiers with confidence.
- Provides seismic separation between wall and ceiling, preserving warranties.
- Ensures validity of installers PS3.
- Tested under ULS and SLS loads to ensure longevity of performance.
- Unique design allows for + or – 50mm of inter story drift.
- Top plate pivot points allow for + or – 45mm of in-line deflection.
- Unique design allows for 20mm of wall “spring back” in ULS event.
- Patented low profile connection bolt allows for clearance in glazing pockets.
- Unit allows a 30° – 60° bracing angle to mitigate service clashes.
- TRACKLOK® VERT allows vertical bracing to mitigate service clashes.
- TRACKLOK® RETRO allows for retroactive installation using 10-gauge wafer tek screws to affix to head track.
- TRACKLOK® TIMBA allows for bracing of timber framed walls using 10-gauge 35mm wood screws to affix to timber top plate. Please note timber top plate must be minimum 90 x 45mm.
- Allows for 64mm and 92mm bracing to be used, reducing waste on site.

OBJECTIVES/

- Prevent injury caused by failure of all types of internal partition wall and glazing line systems due to seismic activity.
- Prevent loss of amenity caused by the behaviour of all types of internal partition wall and glazing line systems during seismic activity.
- Protect property and structures from physical damage caused by the failure of all types of internal partition wall and glazing line systems due to seismic activity.
- Preserve ceiling manufacturer's warranty by providing required seismic separation of partition and glazing lines from ceiling system.
- Prevent business interruption caused by the failure of all types of internal partition wall and glazing line systems due to seismic activity.
- Create efficiencies in construction of all types of internal partition wall and glazing lines.

COMPLIANCE/

- Complies with NZ Building Code Clause B1-Structure
- Complies with NZ Building Code Clause B2-Durability
- Contributes to compliance with NZ Building Code Clause F6 – Visibility in Escape Routes and Clause D1 – Access Routes.

APPLICATIONS/

- Importance Level 2, 3 and 4 Buildings
- Hospitals
- Commercial Interiors
- Schools

INSTALL INSTRUCTIONS/

- 1/ Set out head track (clamp or screw temporarily) must be min .75 BMT steel or min 1.3mm aluminium.
- 2/ Measure TRACKLOK® placements (refer to TRACKLOK® specification sheet).
- 3/ Create 30mm - 40mm clearance hole in ceiling tile with holesaw (pilot bit marks centre point on head track).
- 4/ Enlarge pilot hole in head track to 9mm. RETRO affixed to head track with 10-gauge wafer tek screws. TIMBA affixed to 90mm x 45mm timber top plate with minimum 10-gauge 35mm wood screws.
- 5/ Bolt TRACKLOK® firmly to head track using washer and bolt provided.
- 6/ Measure distance to structure from fly plate below screw holes and cut your brace material to length as per chart provided.
- 7/ Connect bracing material to TRACKLOK® fly brace and top plates.
- 8/ Fix TRACKLOK® top plates to structure with approved anchor.
- 9/ Remove temporary fixings.

For further installation and limitation information please refer to TRACKLOK® Terms and Conditions on page 48 or at www.tracklok.com.

PLENUM HEIGHT CHART/

PLENUM HEIGHT MM/	64 OR 92MM X 0.55BMT STUDS*/	64 OR 92MM X 0.55BMT BOXED STUDS*/	64 OR 92MM X 0.75BMT BOXED STUDS*/
0 - 2000	241kgf/2.37kN	241kgf/2.37kN	241kgf/2.37kN
2000 - 3150	-	241kgf/2.37kN	241kgf/2.37kN
3150 - 4000	-	-	241kgf/2.37kN

* Stud to TRACKLOK® connection to consist of 6/10g tek screws.

TRACKLOK ELEVATIONS/

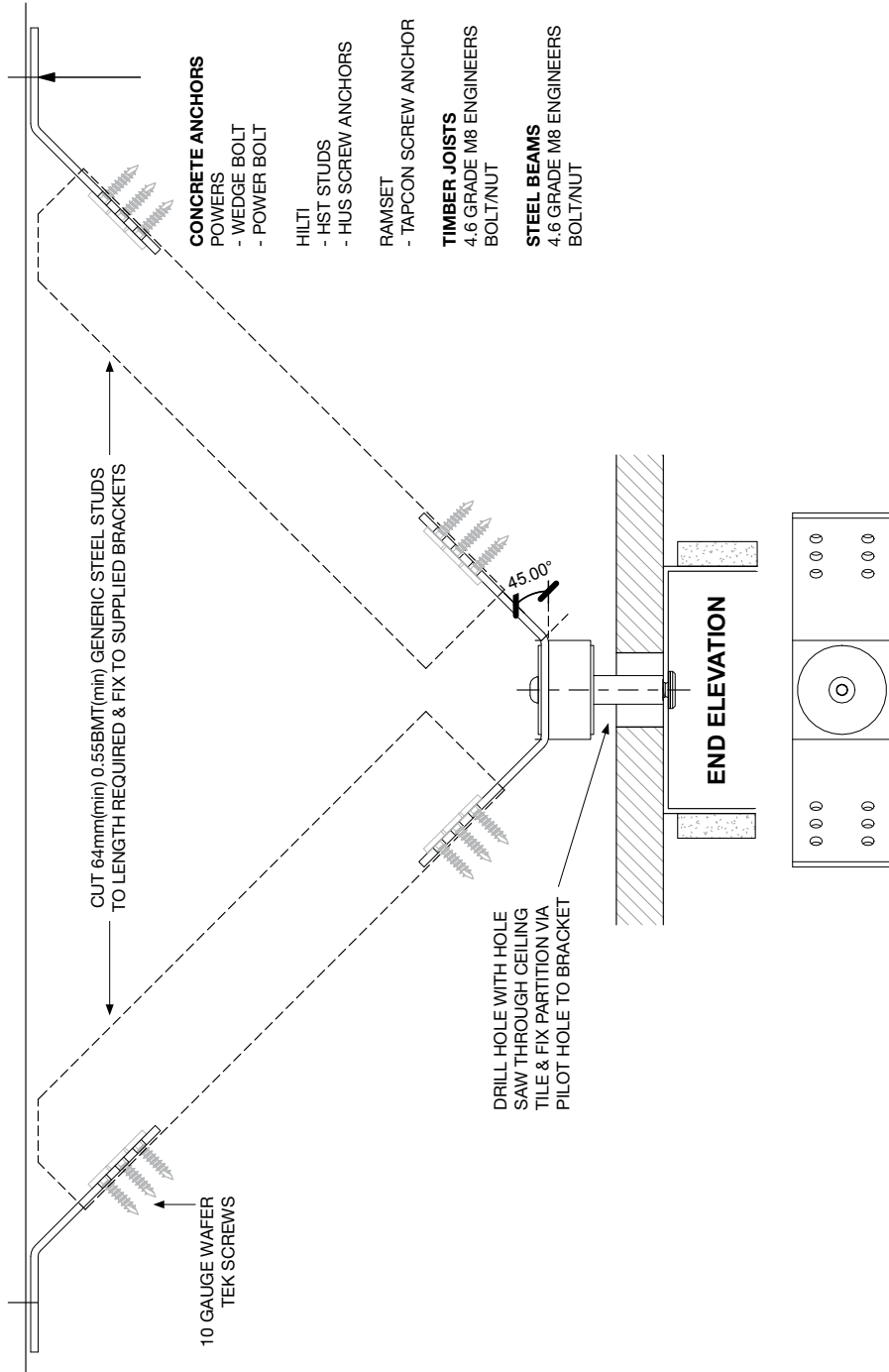

SEISMIC ZONE CHART/

HEIGHT	< 3M	< 6M	< 9M	9M +
ZONE 1	CHART 1	CHART 1	CHART 1	CHART 1
ZONE 2	CHART 1	CHART 1	CHART 2	CHART 2
ZONE 3	CHART 1	CHART 2	CHART 2	CHART 3

NOTES

- 1/ Height (m) is to floor above partition.
- 2/ Allows for 50mm of inter story drift.
- 3/ For wall heights up to 3.0m.
- 4/ For wall weights up to 40kg per m2.
- 5/ For wall weights heavier than 40kg per m2 and for Importance Level 3 and 4 Buildings please contact TRACKLOK® Ltd.

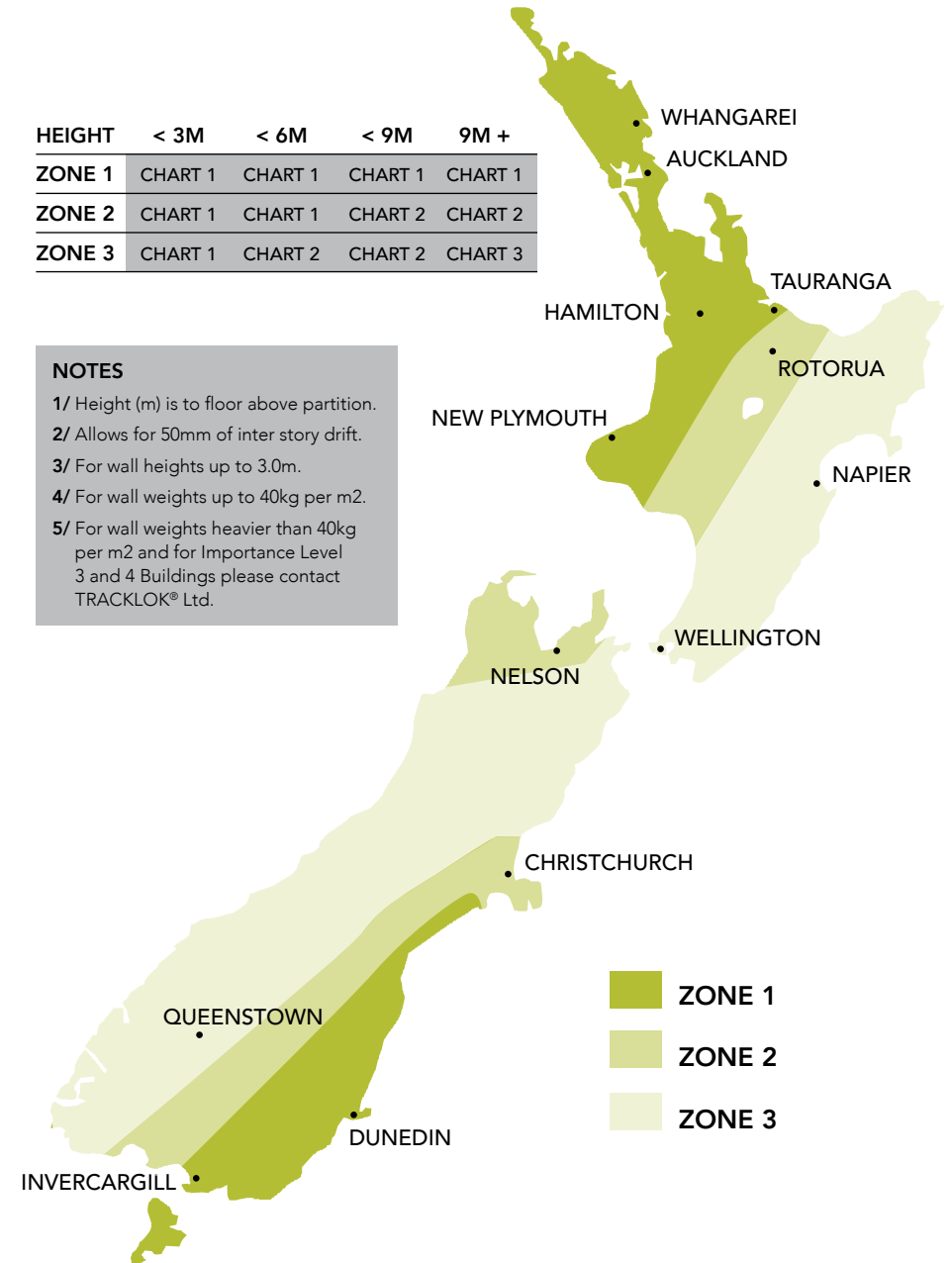
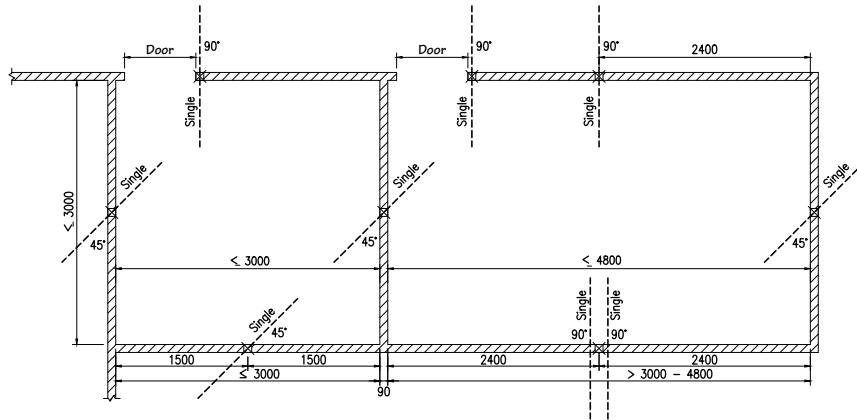
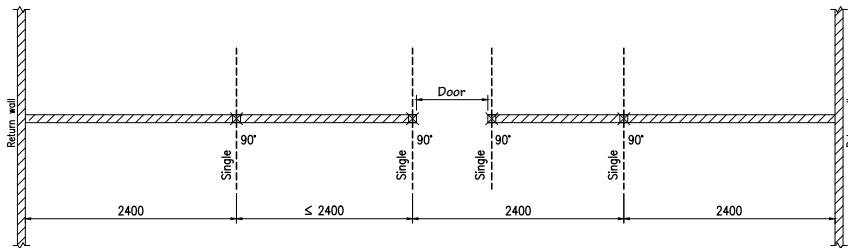

CHART ONE/



BRACING AROUND SMALL ROOMS



BRACING BETWEEN RETURN WALLS

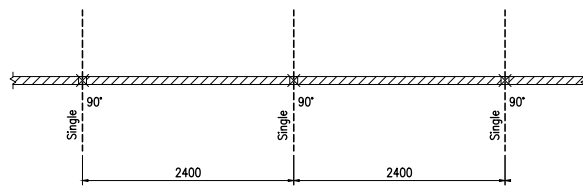

STRAIGHT WALLS WITH NO RETURN WALLS

AUCKLAND/ all levels

WELLINGTON/ up to 3.0m above ground

CHRISTCHURCH/ up to 6.0m above ground

NOTES

- 1/ Height (m) is to floor above partition.
- 2/ Spacings based on horizontal load < 0.75 kN/m
- 3/ Allows for 50mm of inter story drift.
- 4/ For wall heights up to 3.0m.
- 5/ For wall weights up to 40kg per m².
- 6/ Each dashed line represents one brace.

For wall weights heavier than 40kg per m² and for Importance Level 3 and 4 Buildings please contact TRACKLOK® Ltd.

CHART TWO/

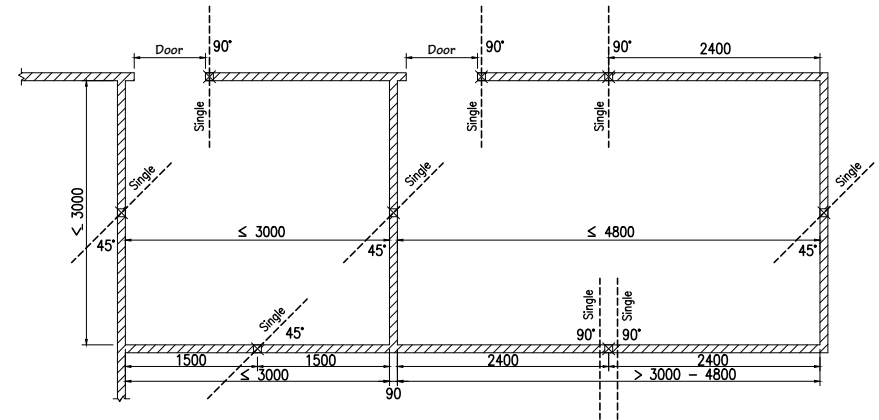

BRACING AROUND SMALL ROOMS

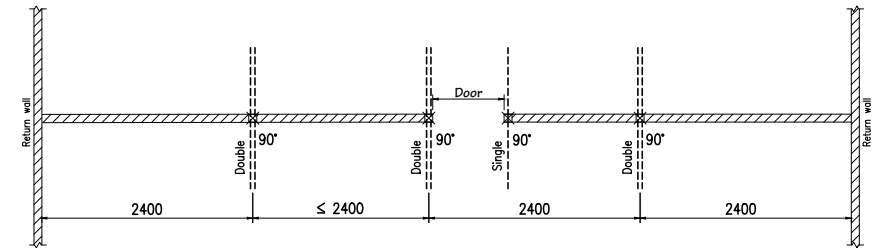

BRACING BETWEEN RETURN WALLS

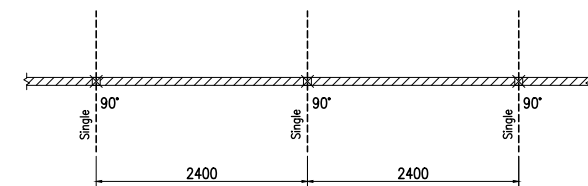

STRAIGHT WALLS WITH NO RETURN WALLS

WELLINGTON/ from 3.0m to 9.0m above ground

CHRISTCHURCH/ above 6.0m from ground

NOTES

- 1/ Height (m) is to floor above partition.
- 2/ Spacings based on horizontal load < 1.20 kN/m
- 3/ Allows for 50mm of inter story drift.
- 4/ For wall heights up to 3.0m.
- 5/ For wall weights up to 40kg per m².
- 6/ Each dashed line represents one brace.

For wall weights heavier than 40kg per m² and for Importance Level 3 and 4 Buildings please contact TRACKLOK® Ltd.

CHART THREE/

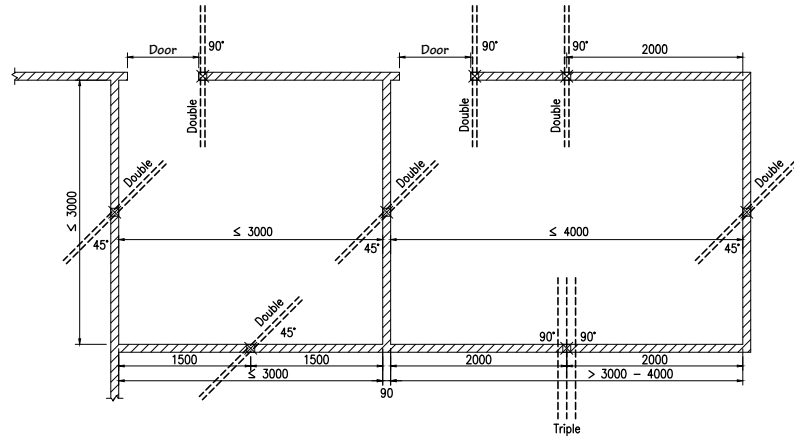

BRACING AROUND SMALL ROOMS

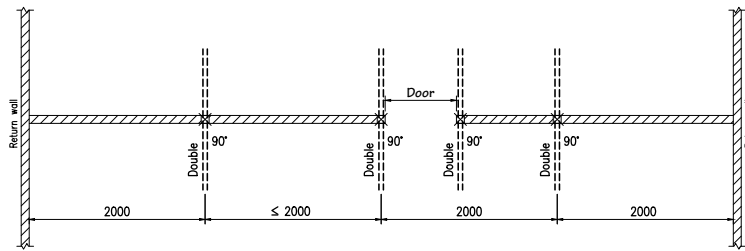

BRACING BETWEEN RETURN WALLS

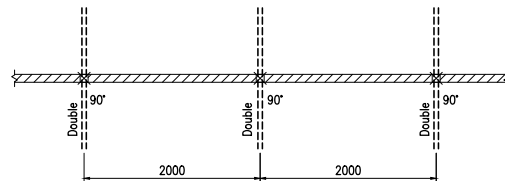

STRAIGHT WALLS WITH NO RETURN WALLS

WELLINGTON/ above 9.0m from ground

NOTES

- 1/ Height (m) is to floor above partition.
- 2/ Spacings based on horizontal load < 1.60 kN/m
- 3/ Allows for 50mm of inter story drift.
- 4/ For wall heights up to 3.0m.
- 5/ For wall weights up to 40kg per m².
- 6/ Each dashed line represents one brace.

For wall weights heavier than 40kg per m² and for Importance Level 3 and 4 Buildings please contact TRACKLOK® Ltd.

GAPLOK/



On occasion, a partition wall or a glazing line placement may coincide with the main runner or nog of a two-way grid ceiling system. In this instance, there would be no way for a TRACKLOK® to pass through the grid, with the required clearance. GAPLOK has been carefully designed, developed and engineered to allow installers to accommodate TRACKLOK® bracing in these instances. GAPLOK provides for 316kgf of capacity.

GAPLOK allows installers to take a 40mm section out of the grid. Clamp GAPLOK to either side of the remaining grid section to bridge the gap, reinstate the grid's structural integrity and allow the clearance required of the TRACKLOK® unit.

STOCK CODE: GGP-10



New Zealand's Ministry of Social Development is located at 56 The Terrace, Wellington. This is an area prone to seismic activity and can be difficult to design for, however the MSD is an important post earthquake agency. TRACKLOK® secured internal, non-structural walls and glazing lines within the building, as it experienced the forces generated by the 2016 7.8 magnitude Kaikoura earthquake, 400kms to the south. Great design and engineering have allowed the MSD to continue its work in a safe environment, post earthquake and TRACKLOK® is proud to have played its part.



TRACKLOK FLAT/



TRACKLOK® FLAT

Wall bracing can need to allow for large amounts of vertical deflection greater than that accommodated by wall build up and/or deflection track. Also, projects with a very high plenum can be impractical to brace. While intense services can leave an installer with no space through which to install a wall brace. These three situations led to the design and development of the engineered solution TRACKLOK® FLAT.

TRACKLOK® FLAT utilises the benefits of the TRACKLOK® design and applies it to horizontally brace partition walls. Employing the principles of a "dragon tie" in residential terms, TRACKLOK® FLAT can brace one wall off another. TRACKLOK® FLAT is revolutionary.

Ensuring seismic separation, providing ceiling clearance and featuring unique adjustability to clear troffer lights, sprinkler pipes and services - TRACKLOK® FLAT is an elegant, yet robust solution. Available in RETRO and TIMBA bases to ensure ease of use.

Steel head track must be a minimum of .75 BMT, while aluminium head track must have a minimum material thickness of 1.3mm. RETRO affixed to head track with 10-gauge wafer tek screws. TIMBA affixed to 90mm x 45mm timber top plate with minimum 10-gauge 35mm wood screws.

STOCK CODE: SPT-10F / SPT-10FR / SPT-10FT

FEATURES AND BENEFITS/

- All products have been tested with steel and aluminium head track to ensure compatibility.
- Steel head track must be a minimum of .75 BMT, while aluminium head track must have a minimum material thickness of 1.3mm.
- Full wall system, quasi static testing provides specifiers with confidence.
- Provides seismic separation between wall and ceiling, preserving warranties.
- Ensures validity of installers PS3.
- Tested under ULS and SLS loads to ensure longevity of performance.
- Unique design allows for unlimited inter story drift.
- Patented low profile connection bolt allows for clearance in glazing pockets.
- TRACKLOK® FLAT can be retroactively installed when combined with a RETRO fitting and using 10-gauge wafer tek screws to affix to head track.
- TRACKLOK® FLAT can brace timber framed walls when combined with a TIMBA fitting and using 35mm 10-gauge wood screws to affix to timber top plate.
- Allows for 64mm and 92mm boxed bracing to be used, reducing waste on site.

OBJECTIVES/

- Prevent injury caused by failure of all types of internal partition wall and glazing line systems due to seismic activity.
- Prevent loss of amenity caused by the behaviour of all types of internal partition wall and glazing line systems during seismic activity.
- Protect property and structures from physical damage caused by the failure of all types of internal partition wall and glazing line systems due to seismic activity.
- Preserve ceiling manufacturer's warranty by providing required seismic separation of partition and glazing lines from ceiling system.
- Prevent business interruption caused by the failure of all types of internal partition wall and glazing line systems due to seismic activity.
- Create efficiencies in construction of all types of internal partition wall and glazing lines.

COMPLIANCE/

- Complies to and provides compliance with NZS 1170.5, AS1170.4 and AS/NZS 4219.
- Provides compliance with NZ Building Code Clause B1 – Structure, B2 – Durability, F2 – Hazardous Building Materials.
- Contributes to compliance with NZ Building Code Clause F6 – Visibility in Escape Routes, Clause D1 – Access Routes.

APPLICATIONS/

- Importance Level 2, 3 and 4 Buildings
- Hospitals
- Commercial Interiors
- Schools

INSTALL INSTRUCTIONS/

- 1/ Set out head track (clamp or screw temporarily) must be min .75 BMT steel or min 1.3mm aluminium.
- 2/ Measure TRACKLOK® FLAT placements (refer to TRACKLOK® FLAT Set Out Guidance).
- 3/ Create 30mm - 40mm clearance hole in ceiling tile with holesaw (pilot bit marks centre point on head track).
- 4/ Enlarge pilot hole in head track to 9mm. RETRO affixed to head track with 10-gauge wafer tek screws. TIMBA affixed to 90mm x 45mm timber top plate with minimum 10-gauge 35mm wood screws.
- 5/ Connect first TRACKLOK® FLAT to head track firmly with attachment method supplied.
- 6/ Measure distance from TRACKLOK® FLAT unit one to unit two and cut 2x lengths of steel stud (.75 BMT) to form box section.
- 7/ Connect bracing material to each TRACKLOK® FLAT unit filling all screw holes.
- 8/ Screw off plasterboard top and bottom and silicone glazing into all channels at 300mm centres.
- 9/ Remove temporary fixings.

For further installation and limitation information please refer to TRACKLOK® Terms and Conditions on page 48 or at www.tracklok.com.

TRACKLOK FLAT ELEVATIONS/

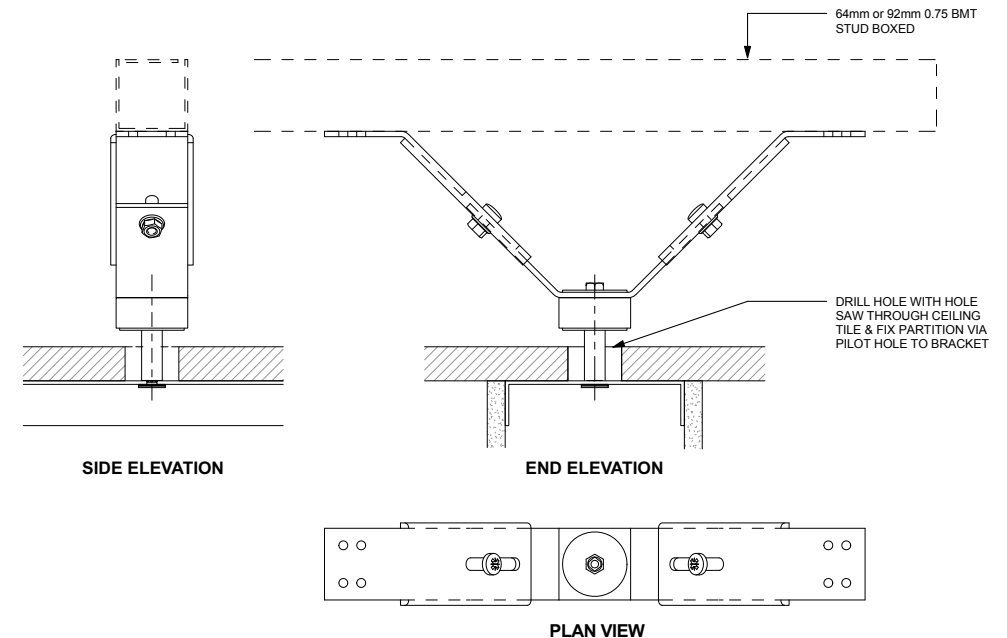

TRACKLOK FLAT PARTITION ELEVATIONS/

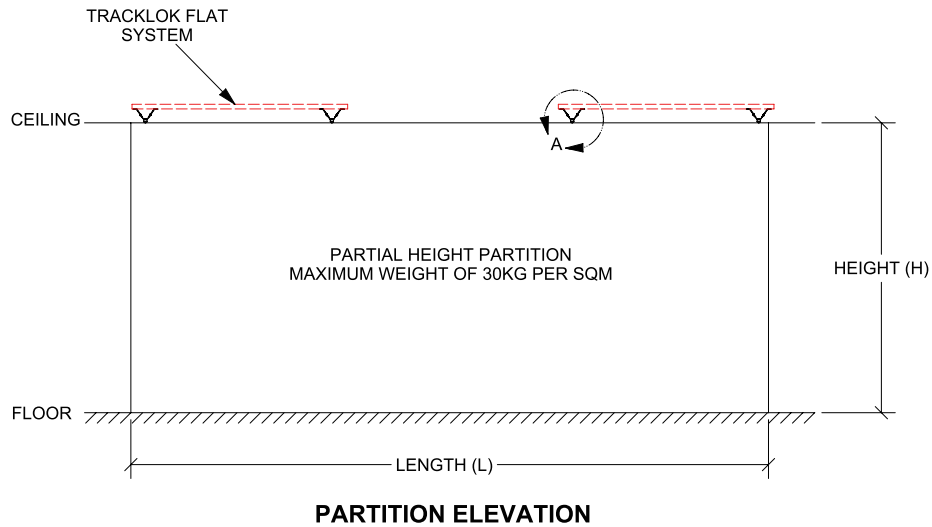

TRACKLOK FLAT PARTITION ELEVATIONS/

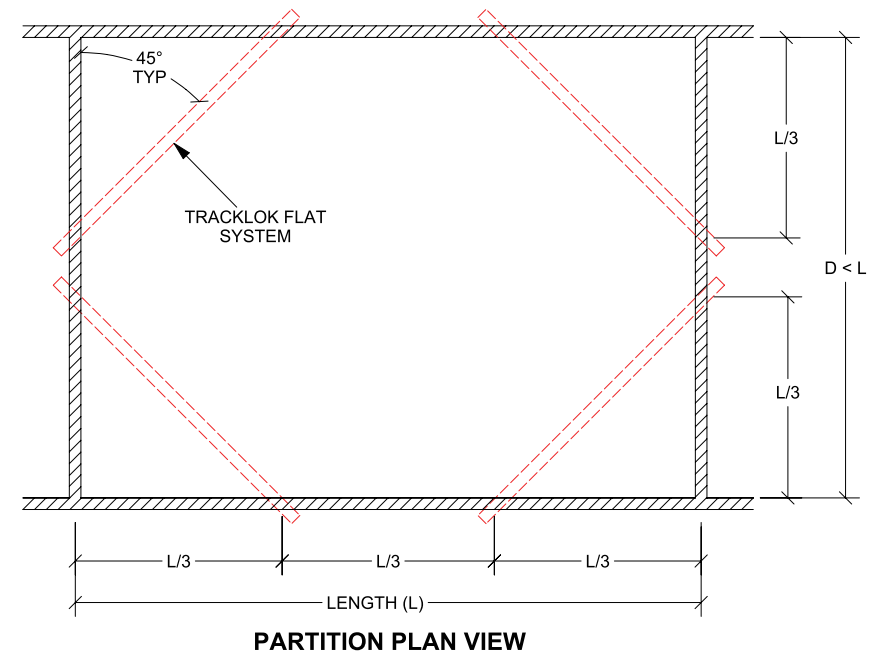

PERMISSIBLE PARTITION LENGTH (L) (MM)

HEIGHT MM/	PARTITION HEADTRACK SIZE/			
	64 X 0.75 BMT/	64 X 1.15 BMT/	92 X 0.75 BMT/	92 X 1.15 BMT/
2500	4800	6150	5550	7000
2750	4800	5590	5050	7000
3000	4630	5120	4630	7000
3250	4270	4730	4270	6710
3500	3960	4390	3960	6230
3750	3700	4100	3700	5820
4000	3470	3840	3470	5450

NOTES

- Partition walls are to be internal and non-load bearing
- Structural engineer should confirm strength of partition studs and connections
- Partition walls to be lined both sides with 10mm(min) plasterboard to transfer shear loading
- Permissible partition length shall be taken as the lowest value of in Table 1 when bracing various headtrack sizes. For example when a 64x0.75BMT is braced to a 92x1.15BMT the permissible wall length is that of the 64x0.75BMT headtrack
- Based upon a maximum partition weight of 30kg per square metre
- Minimum yield strength of 270mpa and ultimate strength 330MPA required for generic steel studs
- All steel stud brace material must be boxed min .75BMT (see page 26 for detail)

CONCRETE CONNECTION DETAILS/

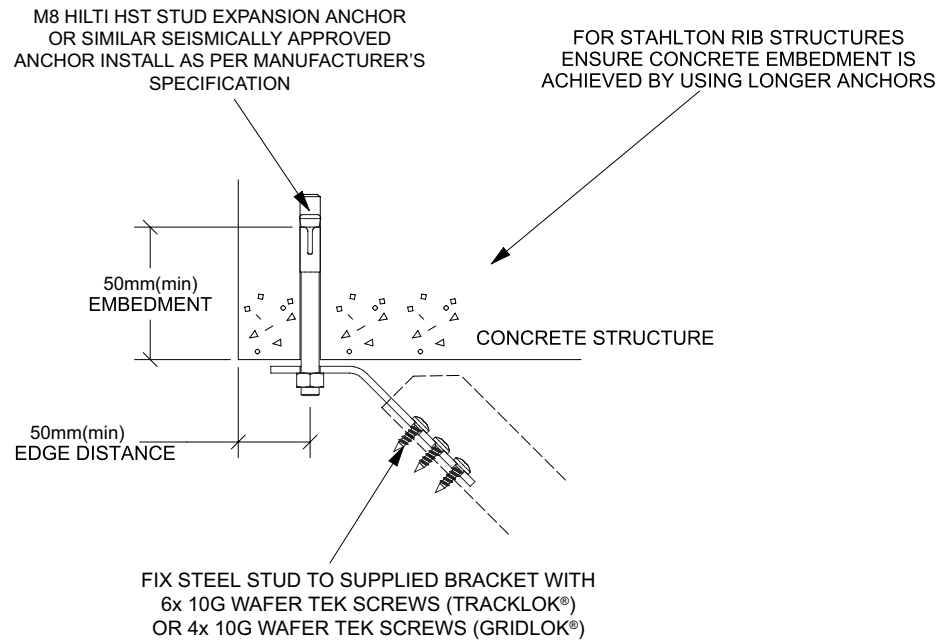

COMFLOR CONNECTION DETAILS/

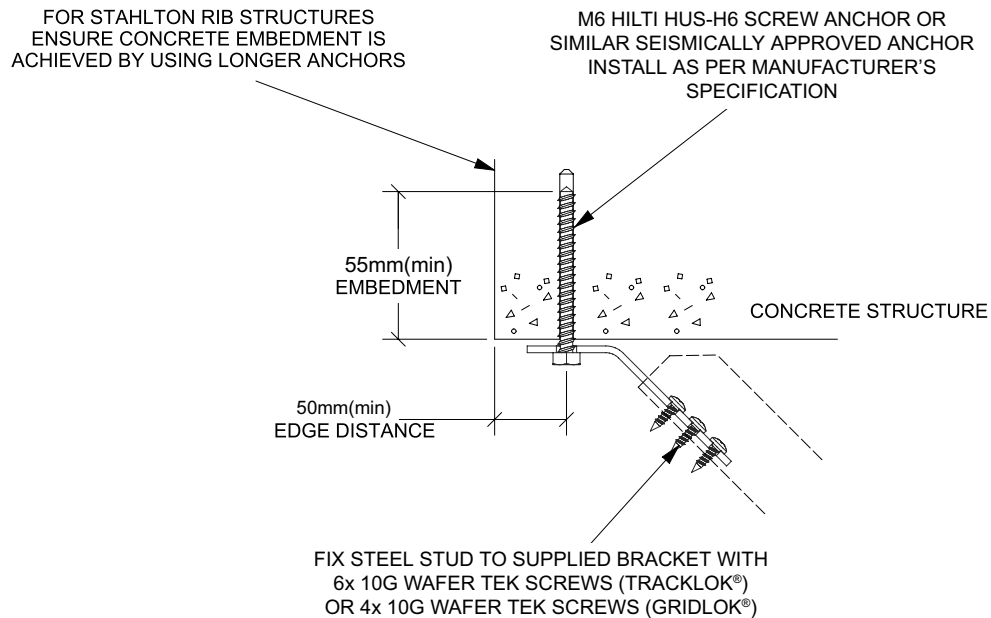
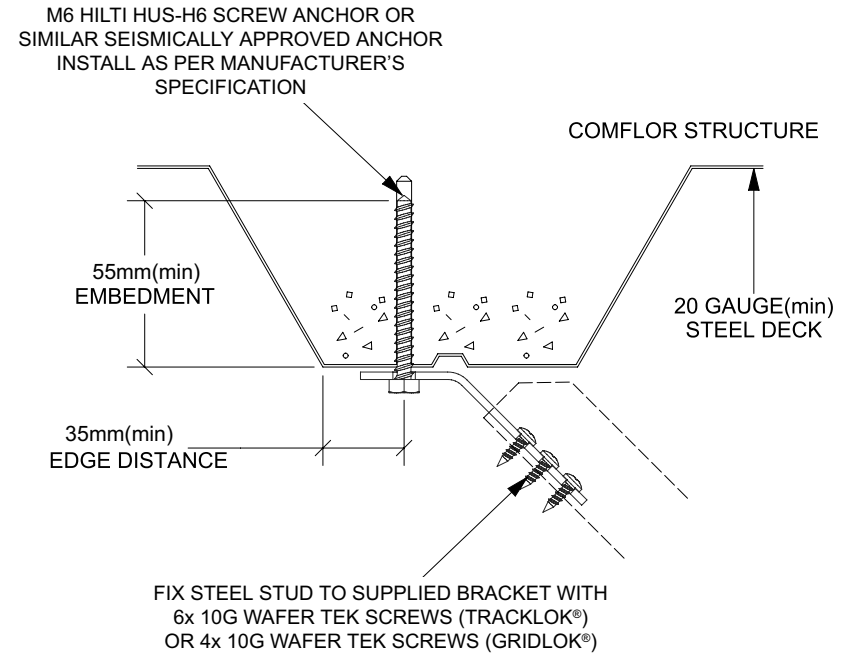

PARALLEL STEEL CONNECTION DETAILS/

TEK SCREW FIXING

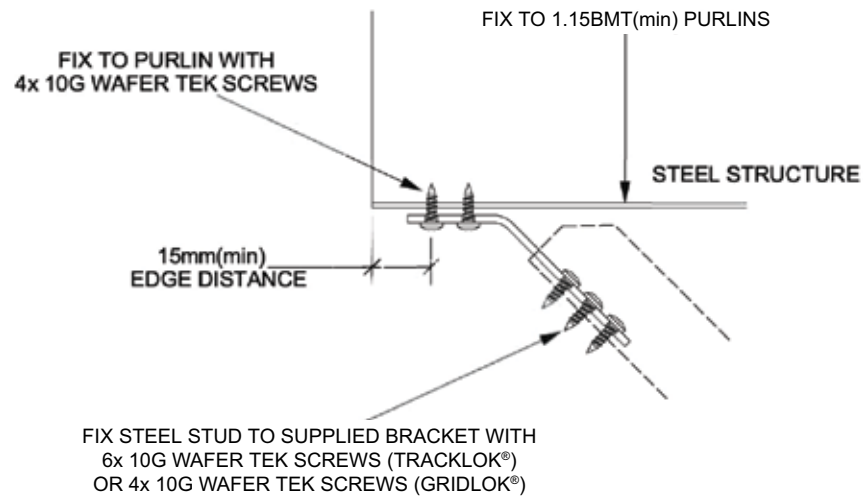

BOLT FIXING

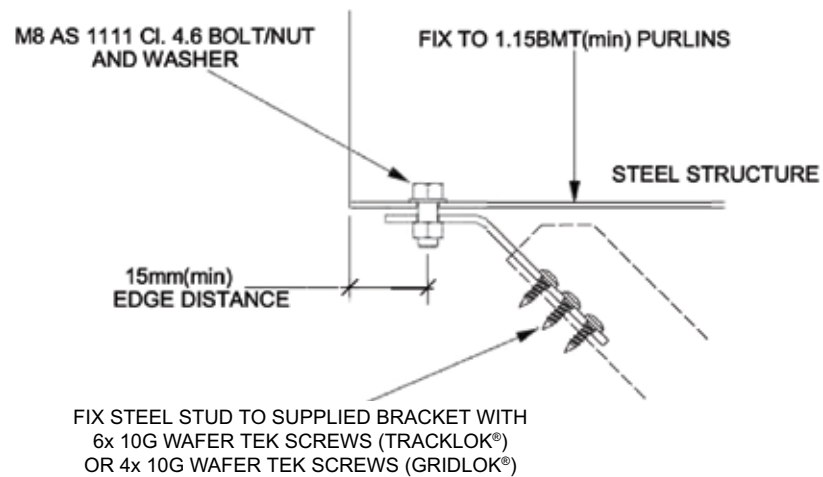

PERPENDICULAR STEEL CONNECTION DETAILS/

TEK SCREW FIXING

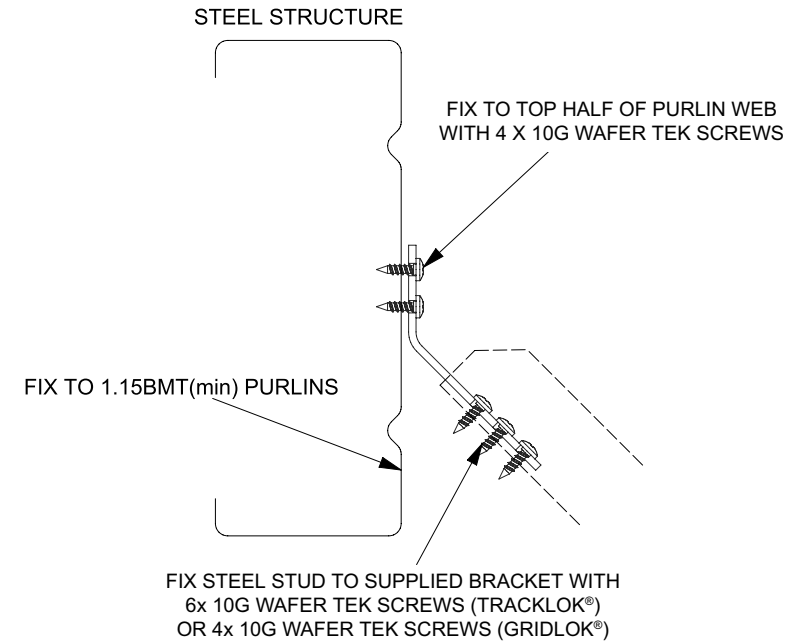

BOLT FIXING

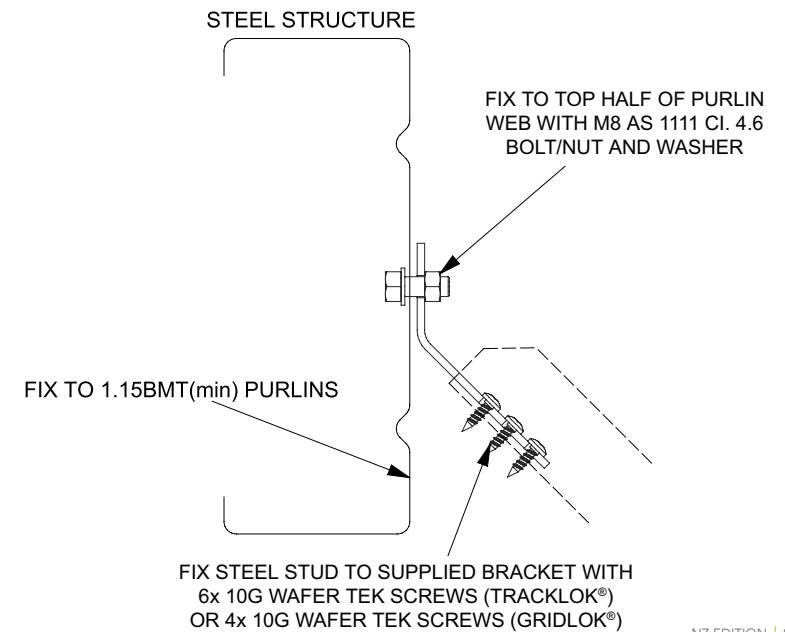

PARALLEL TIMBER CONNECTION DETAILS/

WOOD SCREW FIXING

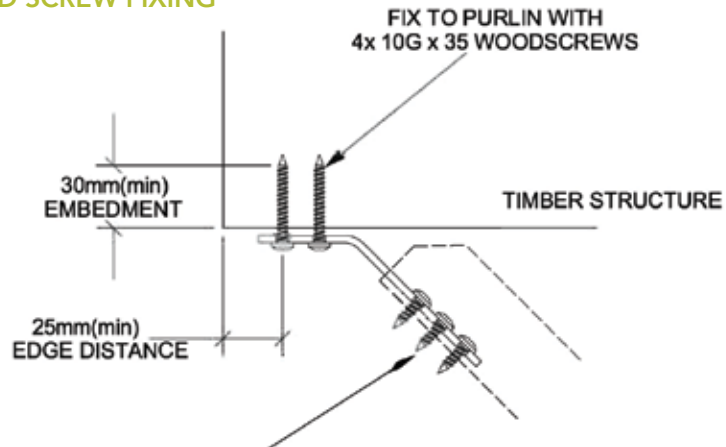

FIX STEEL STUD TO SUPPLIED BRACKET WITH
6x 10G WAFER TEK SCREWS (TRACKLOK®)
OR 4x 10G WAFER TEK SCREWS (GRIDLOK®)

COACH SCREW FIXING

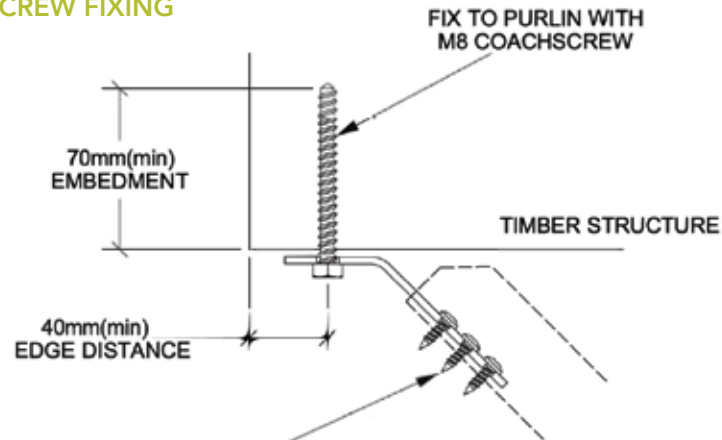

FIX STEEL STUD TO SUPPLIED BRACKET WITH
6x 10G WAFER TEK SCREWS (TRACKLOK®)
OR 4x 10G WAFER TEK SCREWS (GRIDLOK®)

NOTES

- Structural engineer should confirm loading into the purlins is acceptable
- Bridge detail suitable for TRACKLOK® (241kg vertical and horizontal)

PERPENDICULAR TIMBER CONNECTION DETAILS/

WOOD SCREW FIXING

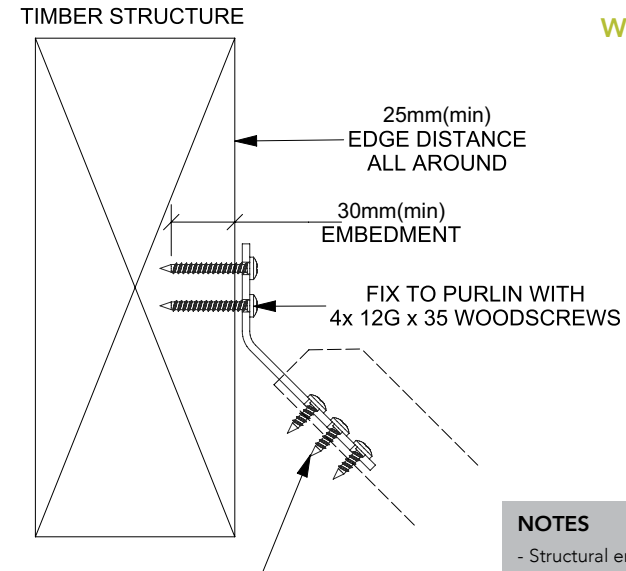

FIX STEEL STUD TO SUPPLIED BRACKET WITH
6x 10G WAFER TEK SCREWS (TRACKLOK®)
OR 4x 10G WAFER TEK SCREWS (GRIDLOK®)

NOTES

- Structural engineer should confirm loading into the purlins/joists is acceptable
- Bridge detail suitable for TRACKLOK® (241kg vertical and horizontal)

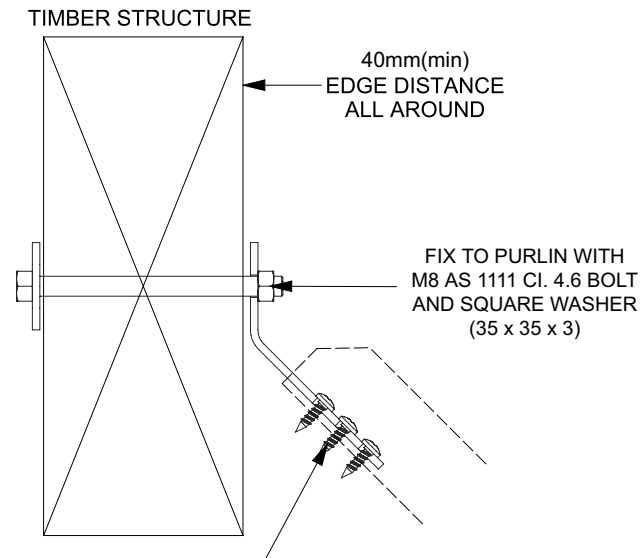

FIX STEEL STUD TO SUPPLIED BRACKET WITH
6x 10G WAFER TEK SCREWS (TRACKLOK®)
OR 4x 10G WAFER TEK SCREWS (GRIDLOK®)

BOLT FIXING

PARALLEL BRIDGE DETAIL/

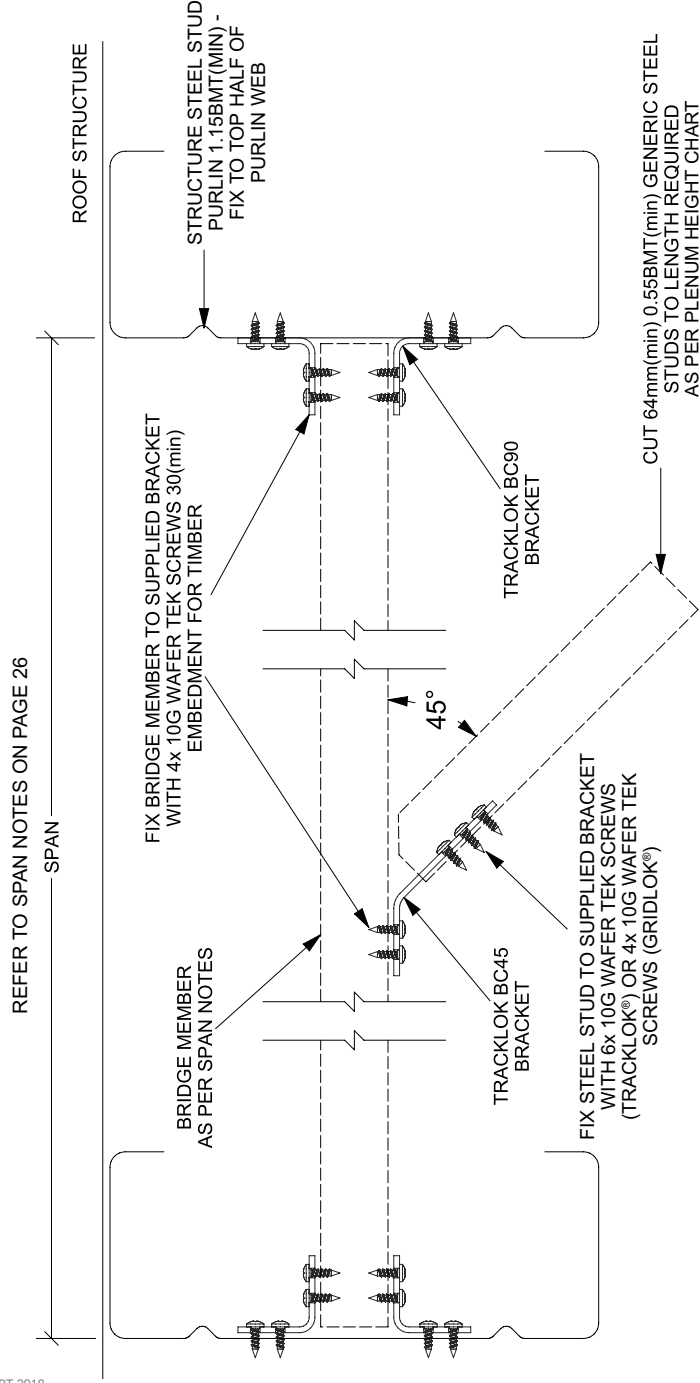

PERPENDICULAR BRIDGE DETAIL/

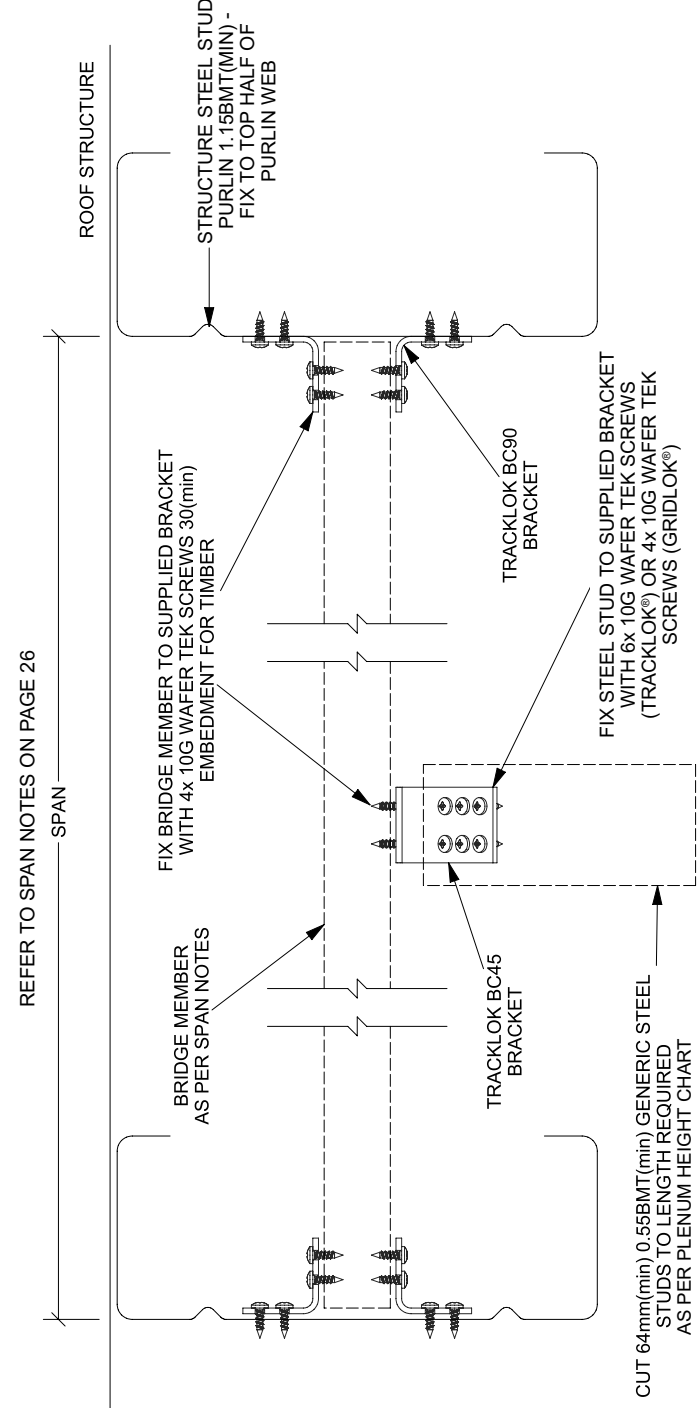

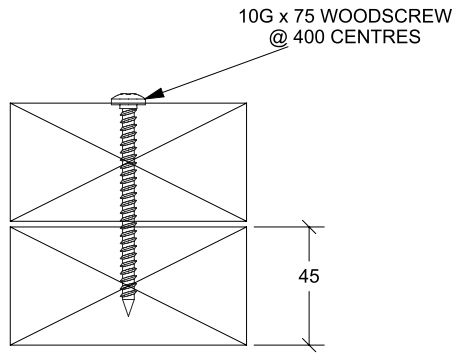

TIMBER DETAIL

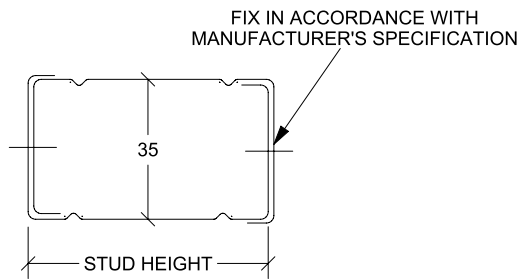

BOXED STUD DETAIL

SPAN NOTES

- Boxed 92mm 0.75BMT(min) generic steel studs maximum permissible span of 950mm
- Boxed 150mm 0.75BMT(min) generic steel studs maximum permissible span of 1500mm
- 90 x 45 SG8 Radiata Pine or Douglas Fir timber maximum permissible span of 850mm
- 2x 70 x 45 SG8 Radiata Pine or Douglas Fir timber maximum permissible span of 1500mm
- 2x 90x 45 SG8 F5 Radiata Pine or Douglas Fir timber maximum permissible span of 2000mm

NOTES

- Structural engineer should confirm loading into the purlins is acceptable
- Bridge detail suitable for TRACKLOK®, TRACKLOK® VERT, GRIDLOK®, (210kg vertical and horizontal)

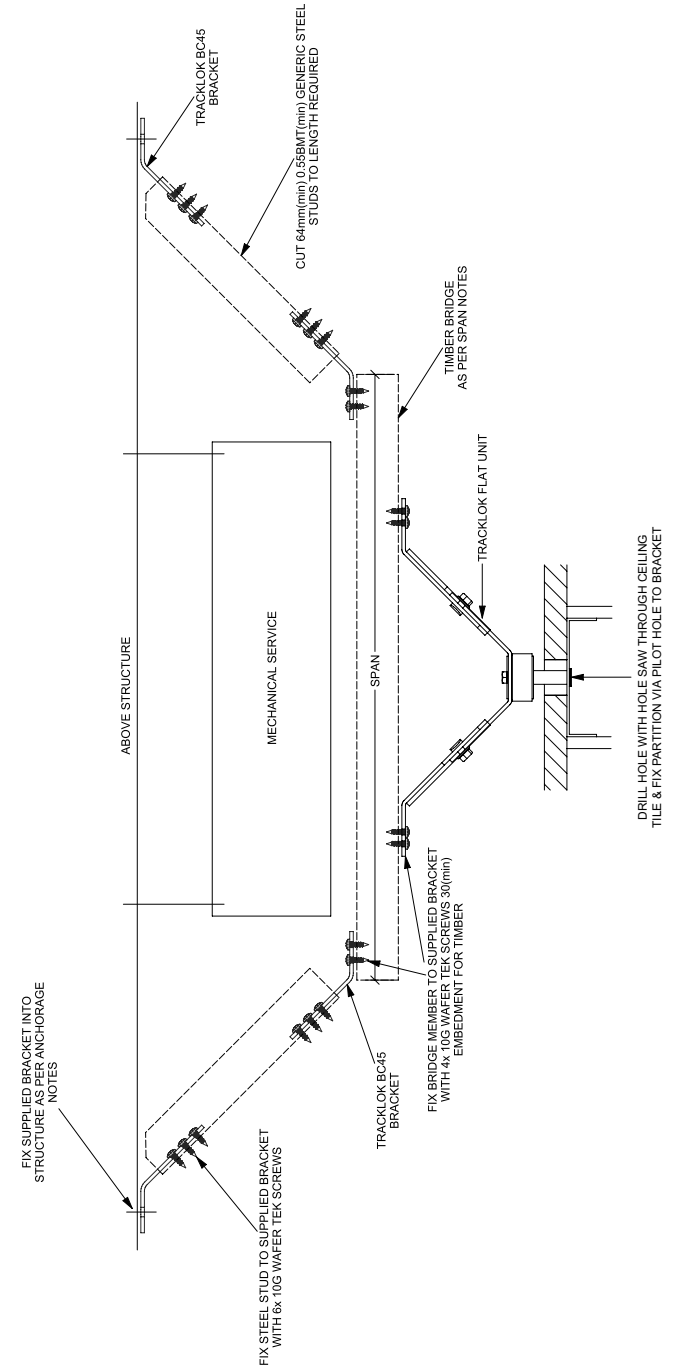

SERVICE BRIDGE DETAIL NOTES/

10G x 75 WOODSCREW
@ 400 CENTRES

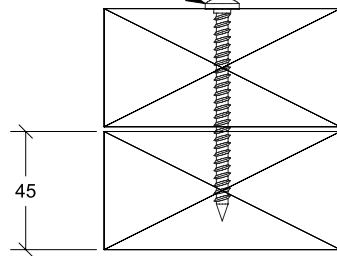

TIMBER DETAIL

FIX IN ACCORDANCE WITH
MANUFACTURER'S SPECIFICATION

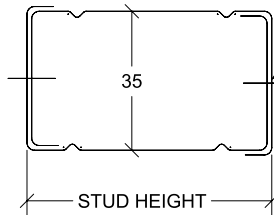

BOXED STUD DETAIL

STRUCTURE ANCHORAGE NOTES

CONCRETE:

- M8 HILTI HST stud anchor 50mm(min) embedment
- M8 HILTI HUS screw anchor 50mm(min) embedment

STEEL:

- M8 CI. 4.6 bolt/nut into 1.15BMT(min)
- 4x 10g wafer tek screws into 0.75BMT(min)

TIMBER:

- M8 x 75mm coach screw full penetration
- M8 CI. 4.6 bolt/nut with 20mm x 20mm x 1.5mm washer
- 4x 10g x 35mm woodscrews 30mm(min) penetration

NOTES

- Structural engineer should confirm loading into the purlins is acceptable
- Bridge detail suitable for TRACKLOK®, (210kg vertical and horizontal)

SPAN NOTES

- Boxed 92mm 0.75BMT(min) generic steel studs maximum permissible span of 950mm
- Boxed 150mm 0.75BMT(min) generic steel studs maximum permissible span of 1500mm
- 90 x 45 SG8 Radiata Pine or Douglas Fir timber maximum permissible span of 850mm
- 2x 70 x 45 SG8 Radiata Pine or Douglas Fir timber maximum permissible span of 1500mm
- 2x 90x 45 SG8 Radiata Pine or Douglas Fir timber maximum permissible span of 2000mm

BULKHEAD BRACING DETAIL/

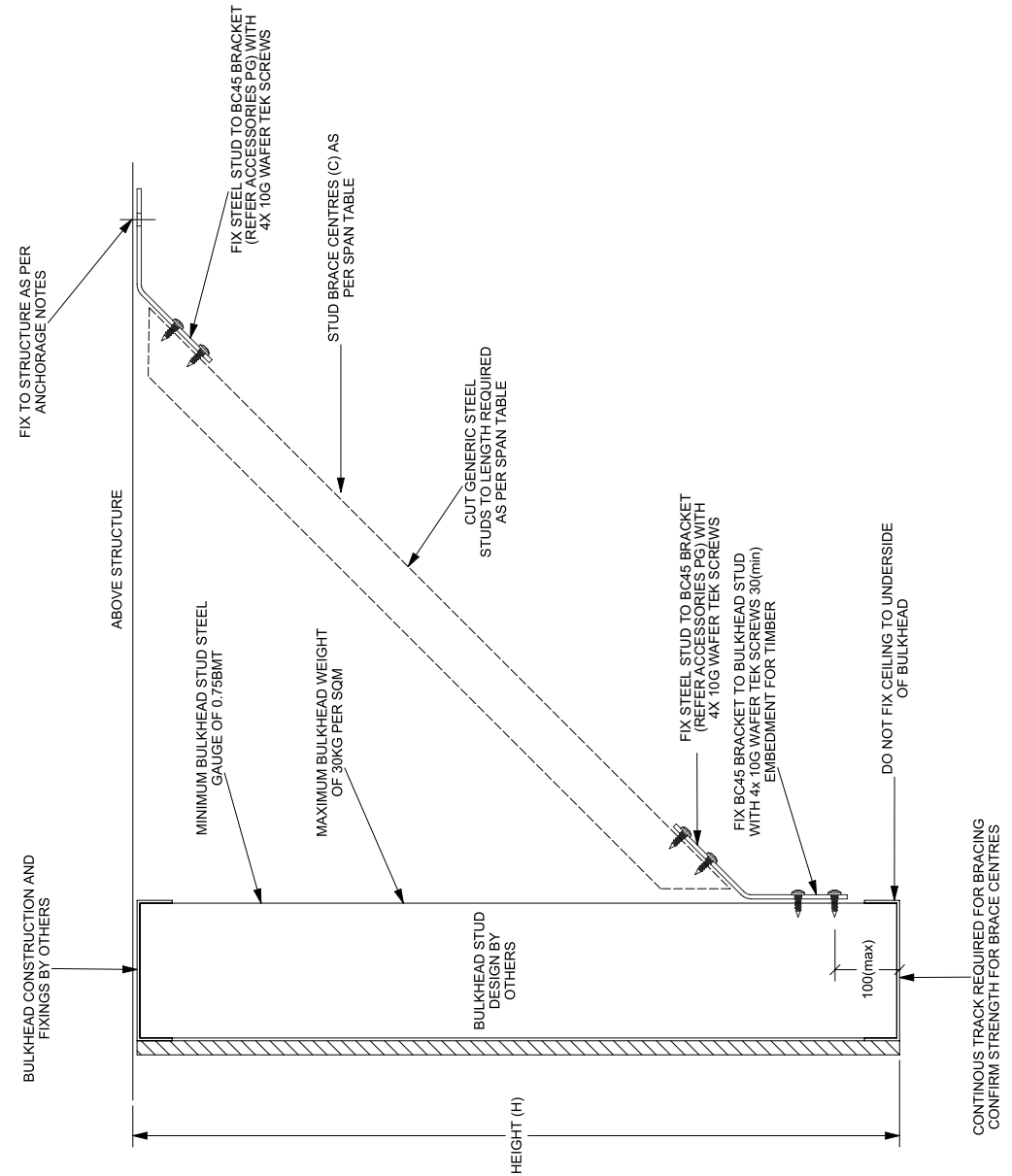

BULKHEAD BRACING DETAIL NOTES/

PERMISSIBLE BRACE CENTRES (C) MM

HEIGHT MM/	STEEL STUD BRACE SIZE/	
	64MM .55 BMT	92MM .75 BMT
1600	2400	2400
1800	1600	2400
2000	1200	2400
2200	900	1500
2400	700	1200
2600	500	900
2800	400	700
3000	300	600

STRUCTURE ANCHORAGE NOTES

CONCRETE:

- M8 HILTI HST stud anchor 50mm(min) embedment
- M6 HILTI HUS-H6 screw anchor 55mm(min) embedment

STEEL:

- M8 Cl. 4.6 bolt/nut into 1.15BMT(min)
- 4x 10g wafer tek screws into 0.75BMT(min)

TIMBER:

- M8 x 75mm coach screw full penetration
- M8 Cl. 4.6 bolt/nut with 20mm x 20mm x 1.5mm washer
- 4x 10g x 35mm woodscrews 30mm(min) penetration

SPAN NOTES

- Bulkhead is to be internal and non-load bearing
- Structural engineer should confirm strength of bulkhead studs and connections
- Bulkhead to be lined at least one side with 10mm(min) plasterboard to transfer shear loading
- Based upon a maximum bulkhead weight of 30kg per square metre
- Do not attach ceiling to underside of bulkhead. Additional weight needs to be considered
- Continuous track required to transfer load between braces. Design to be confirmed by others
- Minimum bulkhead stud steel gauge of 0.75BMT



GRIDLOK® RANGE/

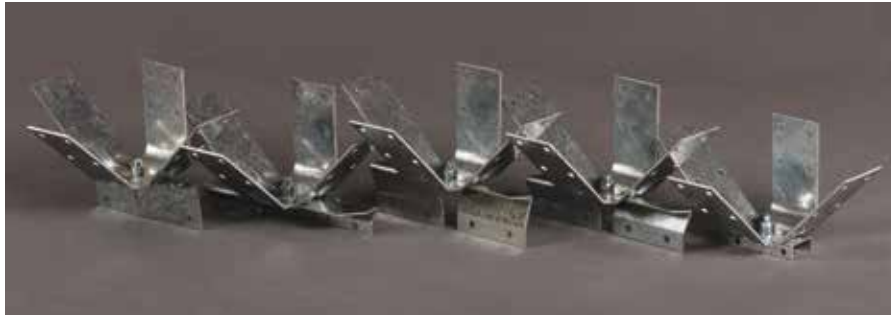

GRIDLOK®

Designed and tested to provide a consistent maximum 280kg/f of bracing capacity to two-way grid ceiling systems and drywall grid systems. A simple click fit and screw off process dramatically reduces time required to complete back bracing. Plenum height chart provides guidance on steel stud BMT required for bracing arms. Features the ability to rotate the unit through 360° minimising service clashes. **STOCK CODE: GRD-10**



GRIDLOK® PEAK FORM

Designed and tested to provide a consistent maximum 280kg/f of bracing capacity to higher profile two-way grid ceiling systems and dry wall grid systems. Simple click fit and screw off process dramatically reduces time required to complete back bracing saving cost to project. Plenum height chart provides guidance on steel stud BMT required for bracing arms. Features the ability to rotate the unit through 360° minimising service clashes. **STOCK CODE: GRD-10P**



GRIDLOK® KWIKLOC

Designed and tested to provide a consistent maximum 280kg/f of bracing capacity to the KWIKLOC ceiling system. Simple click fit and screw off process dramatically reduces time required to complete back bracing. Plenum height chart provide guidance on steel stud BMT required for bracing arms. Features the ability to rotate the unit through 360° minimising service clashes. **STOCK CODE: GRD-10K**



GRIDLOK® SCREW FIX TCR

Designed and tested to provide a consistent maximum 280kg/f of bracing capacity to the top cross rail of plasterboard ceiling systems. Simple click fit and screw off process dramatically reduces time required to complete back bracing. Plenum height chart provide guidance on steel stud BMT required for bracing arms. Features the ability to rotate the unit through 360° minimising service clashes. **STOCK CODE: GRD-10S**

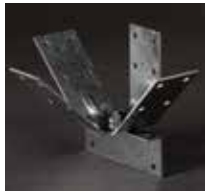

GRIDLOK® C CHANNEL

Designed and tested to provide a consistent maximum 280kg/f of bracing capacity to the C Channel rail of plasterboard ceiling systems. Simple click fit and screw off process dramatically reduces time required to complete back bracing. Plenum height chart provide guidance on steel stud BMT required for bracing arms. Features the ability to rotate the unit through 360° minimising service clashes. **STOCK CODE: GRD-10C**

GRIDLOK® RANGE/



GRIDLOK® U-PROFILE

Designed and tested to provide a consistent maximum 280kg/f of bracing capacity to the Armstrong U-Profile system. Consistency in load capabilities is the key feature, while the ease of installation will dramatically reduce install times. Plenum height chart provide guidance on steel stud BMT required for bracing arms. Get a better result in less time. Features the ability to rotate the unit through 360° minimising service clashes. **STOCK CODE: GRD-10U**

FEATURES AND BENEFITS/

- Provides maximum 280kg/f of capacity for every brace, every time.
- Dramatically reduces install time from up to 1.5 hours to 25 minutes per brace.
- Provides consistency of installation and eliminates installer error.
- Ensures validity of seismic ceiling design and ceiling installers PS3.
- Tested under ULS and SLS loads to ensure longevity of performance.
- Patented connection saddle applicable to all ceiling main runners.
- Allows for 64mm and 92mm steel stud to be used as bracing material.
- Minimises plenum footprint to reduce service clashes.
- Allows rotation of bracing footprint to minimise service clashes.
- Employs .64 BMT, .75 BMT or 1.15 BMT steel stud to minimise waste on site.

COMPLIANCE/

- Complies with NZ Building Code Clause B1-Structure
- Complies with NZ Building Code Clause B2-Durability
- Contributes to compliance with NZ Building Code Clause F6 – Visibility in Escape Routes and Clause D1 – Access Routes.

OBJECTIVES/

- Provide consistent brace capacity for all ceiling types.
- Saves labour and time in the construction of ceiling systems that require bracing.
- Provide a systematic and quantifiable approach to ceiling bracing.
- Prevent injury caused by failure of ceiling systems during seismic activity.
- Prevent loss of amenity caused by behaviour of ceiling systems during seismic activity.
- Protect property and structures from physical damage caused by failure of ceiling systems during seismic activity.
- Prevent business interruption caused by the failure of ceiling systems due to seismic activity.

APPLICATIONS/

- Importance Level 2, 3 and 4 Buildings
- Hospitals
- Commercial Interiors
- Schools

INSTALL INSTRUCTIONS/

- 1/ Place GRIDLOK® on main runner in position specified by ceiling designer, ceiling engineer or ceiling manufacturer.
- 2/ Connect GRIDLOK® to ceiling grid main runner or top cross rail using 10 gauge wafer tek screws.
- 3/ Rotate fly plate to obtain optimum bracing placement on structure over.
- 4/ Ensure ceiling grid is at correct height, measure and cut steel stud, as per chart provided and connect to vertical arm.
- 5/ Attach vertical top connector to structure over.
- 6/ Cut two 45° steel studs as per plenum chart provided, attach to 45° top connectors and 45° GRIDLOK® arms.
- 7/ Attach the 45° top connector to the structure over using approved anchor. Ensure all screw holes are filled.

For further installation and limitation information please refer to GRIDLOK® Terms and Conditions on page 48 or at www.tracklok.com.

PLENUM HEIGHT CHART/

PLENUM HEIGHT MM/	64 X 0.55BMT STUDS*/	92 X 0.75BMT STUDS*/	64 X 0.55BMT BOXED STUDS*/	92 X 0.75BMT BOXED STUDS*/
0 - 600	250kgf/2.45kN	280kgf/2.75kN	250kgf/2.45kN	280kgf/2.75kN
600 - 1000	250kgf/2.45kN	280kgf/2.75kN	250kgf/2.45kN	280kgf/2.75kN
1000 - 1400	250kgf/2.45kN	280kgf/2.75kN	250kgf/2.45kN	280kgf/2.75kN
1400 - 1800	160kgf/1.57kN	270kgf/2.65kN	250kgf/2.45kN	280kgf/2.75kN
1800 - 2200	110kgf/1.07kN	180kgf/1.77kN	250kgf/2.45kN	280kgf/2.75kN
2200 - 2600	80kgf/.78kN	130kgf/1.27kN	250kgf/2.45kN	280kgf/2.75kN
2600 - 3000	60kgf/.58kN	100kgf/.98kN	190kgf/1.86kN	280kgf/2.75kN
3000 - 3500	-	-	140kgf/1.37kN	280kgf/2.75kN
3500 - 4000	-	-	100kgf/.98kN	210kgf/2.05kN

* Stud to GRIDLOK® connection to consist of 4/10g tek screws

GRIDLOK®/

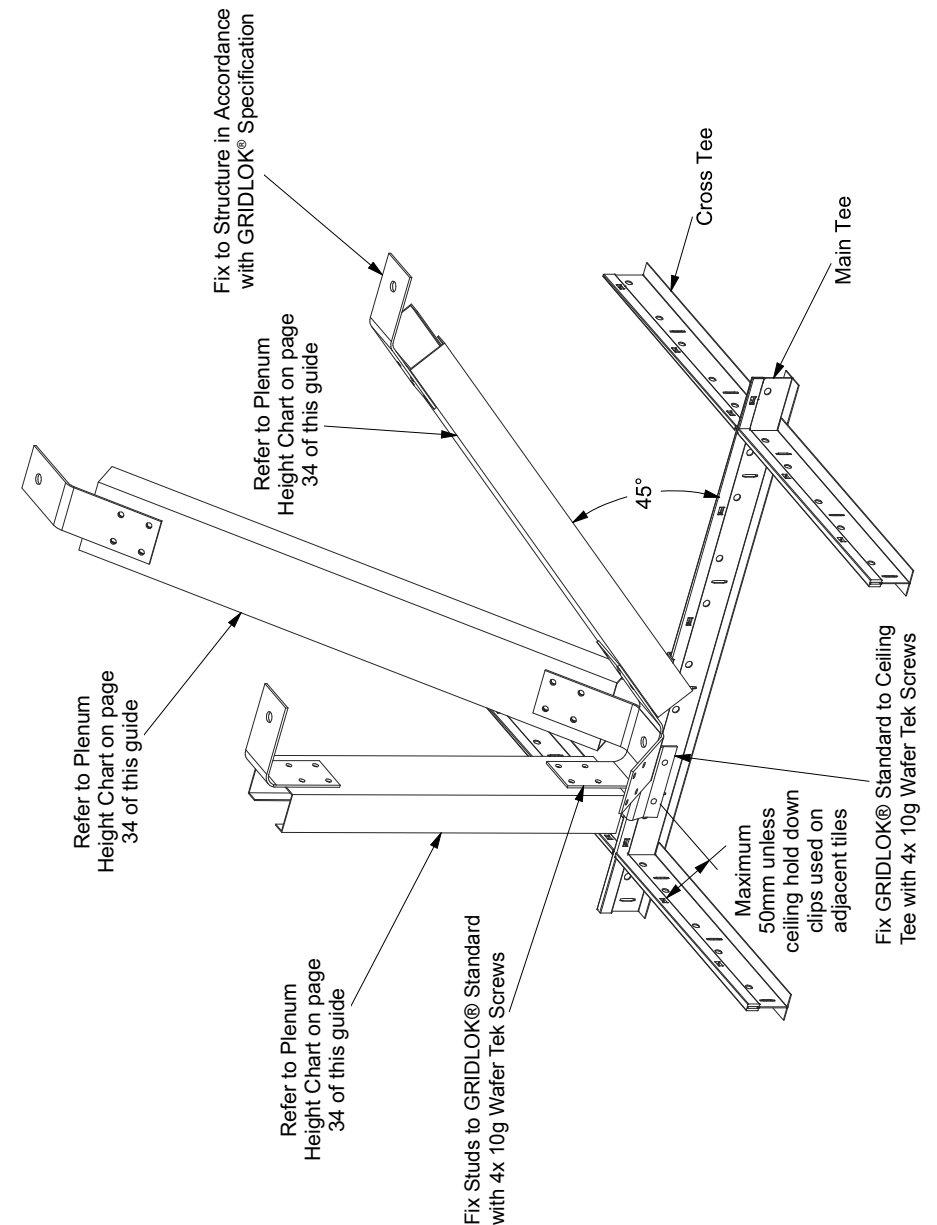

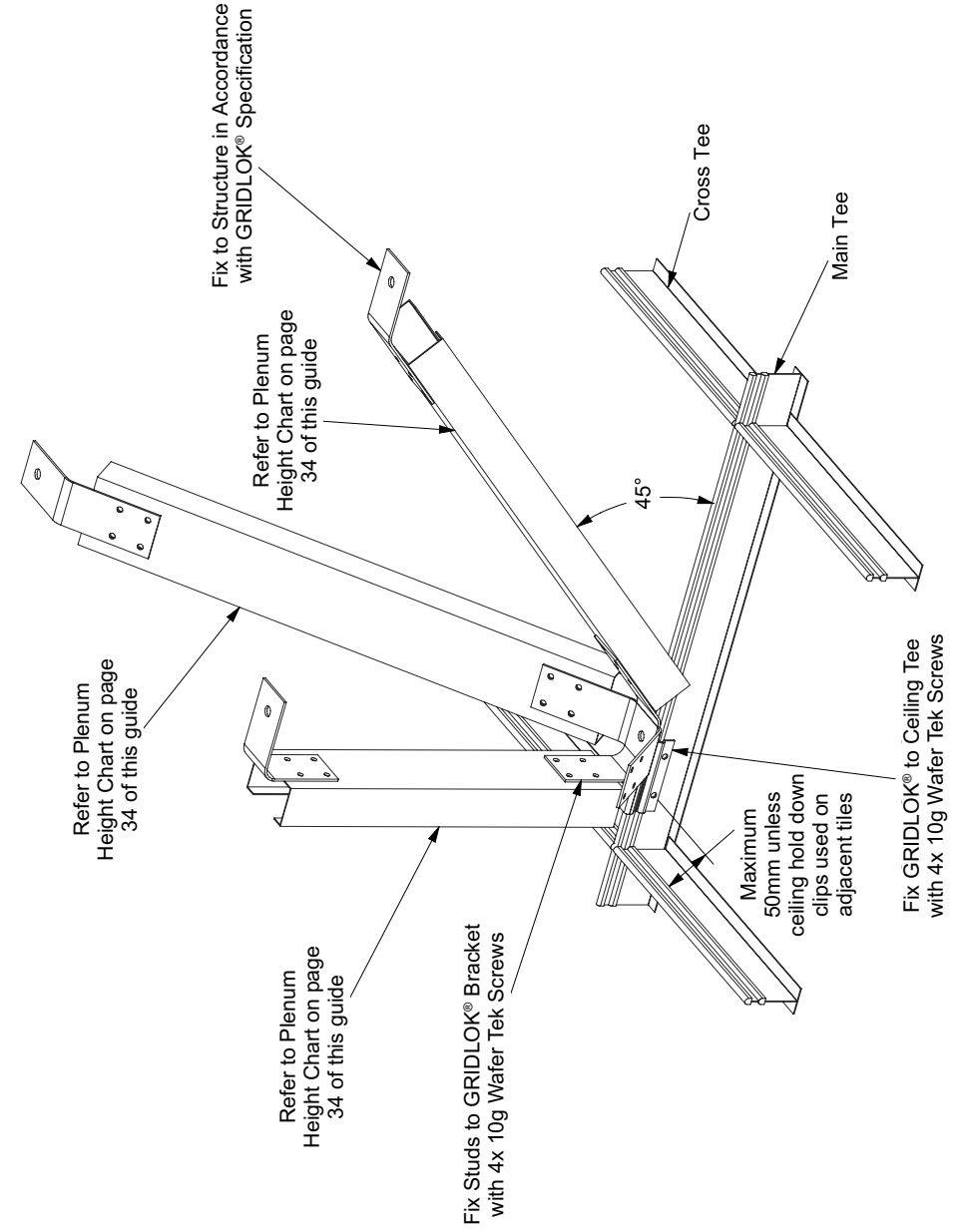
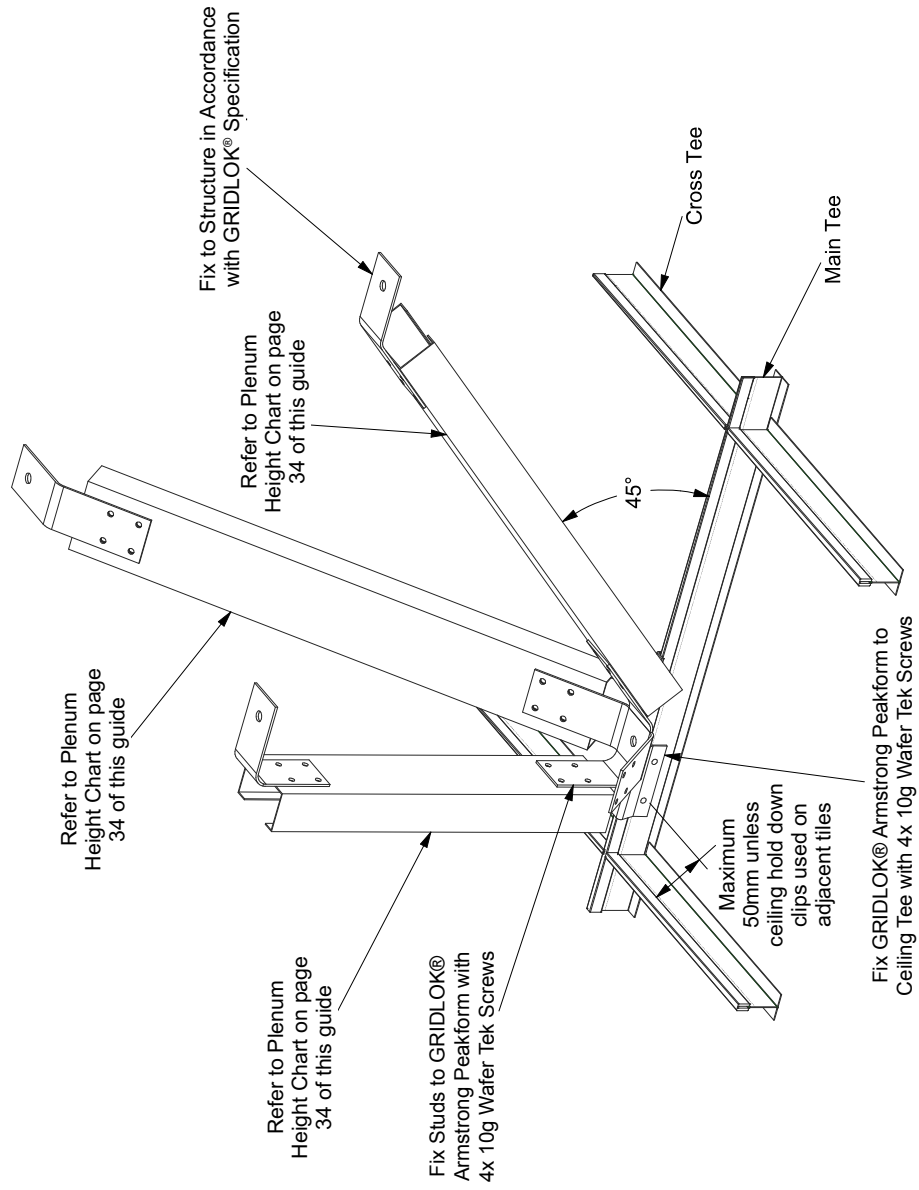

GRIDLOK® TOP CROSS RAIL (TCR)/

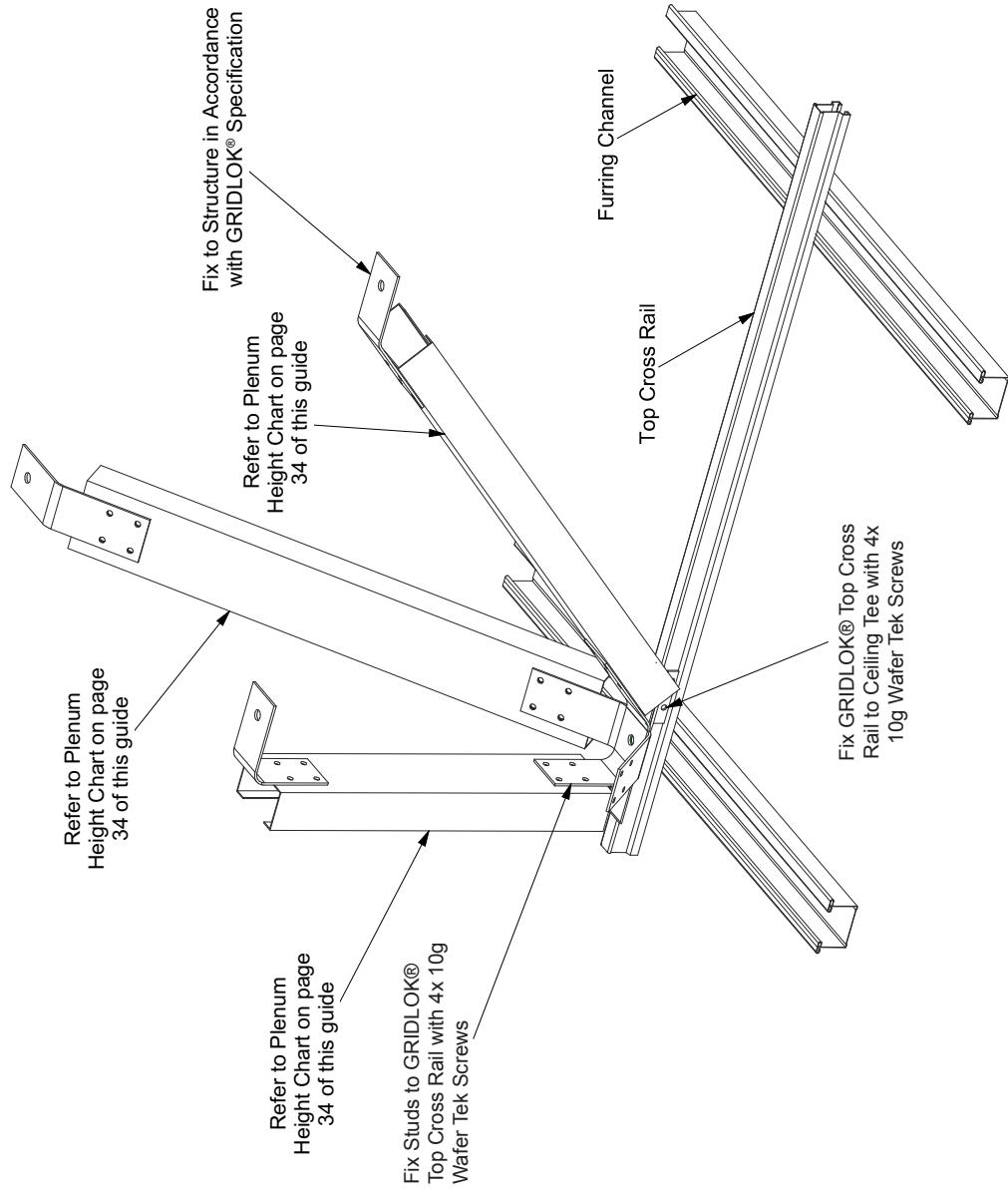

GRIDLOK® C CHANNEL/

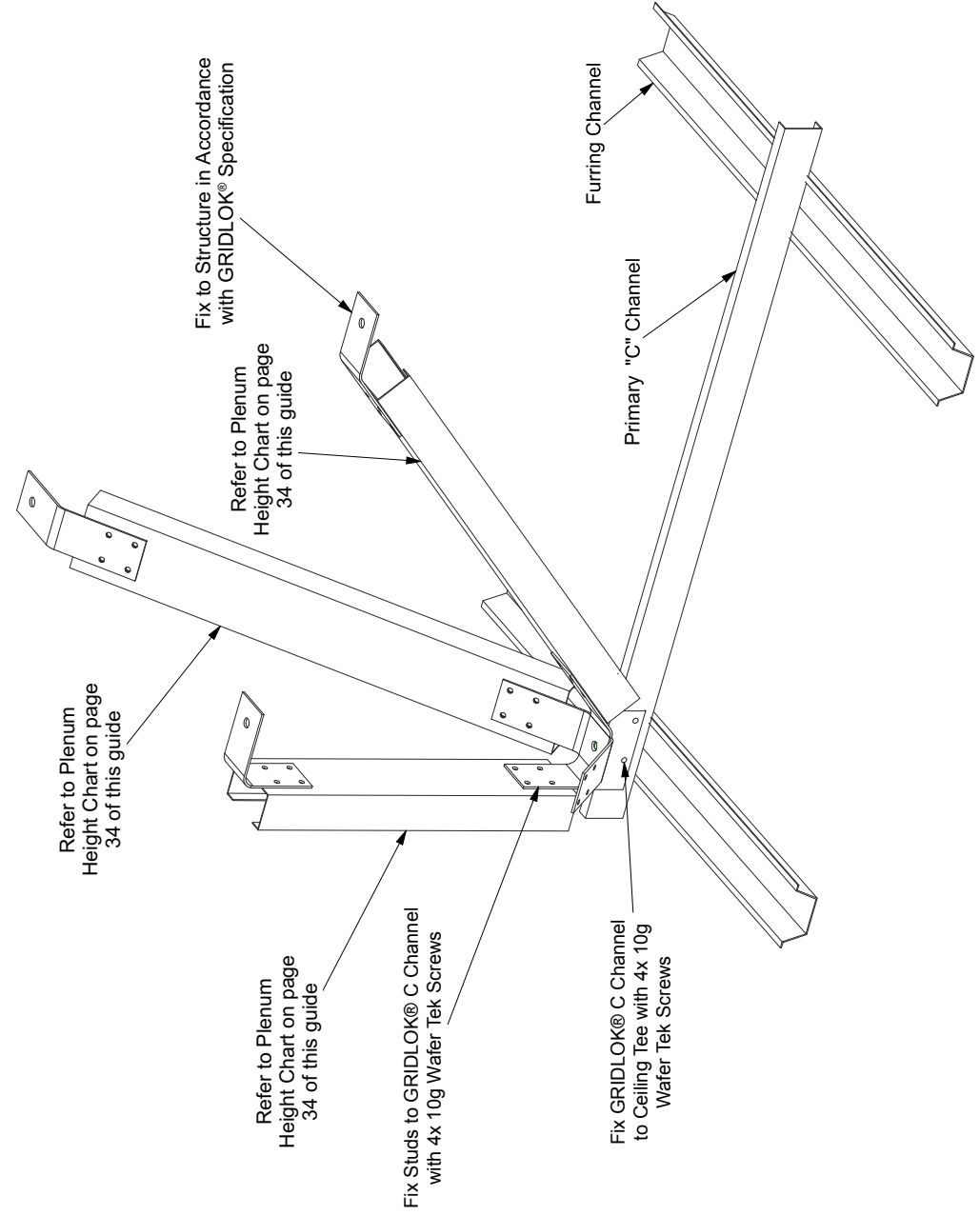

ACCESSORIES - BC45/

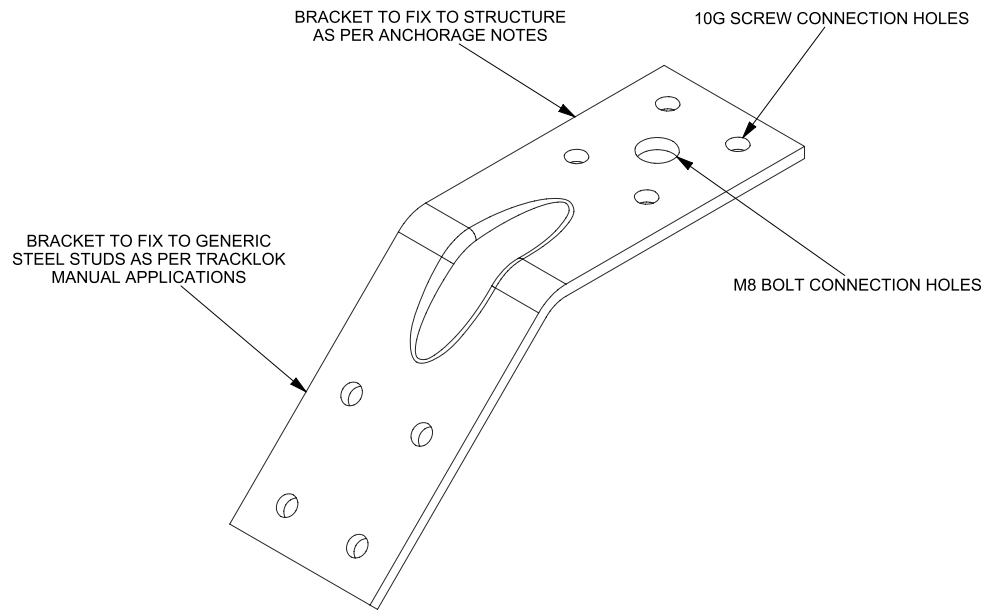

BULKHEAD & BRIDGING CONNECTOR 45

Designed and tested to provide a consistent and quantifiable connection capacity. Used in conjunction with steel stud to brace bulkheads. Our height vs centres chart provides install guidance. Also, used to assist in the bridging of services.

STOCK CODE: BC-45 (SOLD IN PAIRS)

STRUCTURE ANCHORAGE NOTES

CONCRETE:

- M8 HILTI HST stud anchor 50mm(min) embedment
- M6 HILTI HUS-H6 screw anchor 55mm(min) embedment

STEEL:

- M8 CI. 4.6 bolt/nut into 1.15BMT(min)
- 4x 10g wafer tek screws into 0.75BMT(min)

TIMBER:

- M8 x 75 coach screw full penetration
- M8 CI. 4.6 bolt/nut with 20 x 20 x 1.5 washer
- 4x 10g x 35 woodscrews 30mm(min) penetration

NOTES

- Structural engineer should confirm loading into structure
- Consult TRACKLOK® manual for permissible applications
- Do not bend bracket to suit angle

ACCESSORIES - BC90/

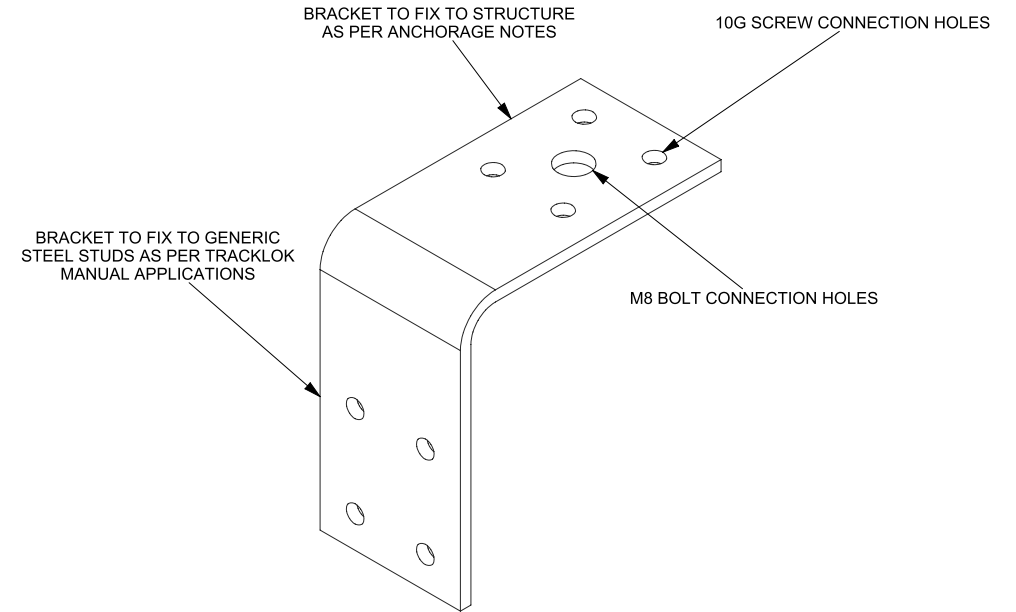

BRIDGING CONNECTOR 90

Designed and tested to provide a consistent and quantifiable connection capacity. Used in conjunction with steel stud to bridge purlins allowing parallel and perpendicular bracing connections.

STOCK CODE: BC-90 (SOLD IN PAIRS)

STRUCTURE ANCHORAGE NOTES

CONCRETE:

- M8 HILTI HST stud anchor 50mm(min) embedment
- M6 HILTI HUS-H6 screw anchor 55mm(min) embedment

STEEL:

- M8 CI. 4.6 bolt/nut into 1.15BMT(min)
- 4x 10g wafer tek screws into 0.75BMT(min)

TIMBER:

- M8 x 75 coach screw full penetration
- M8 CI. 4.6 bolt/nut with 20 x 20 x 1.5 washer
- 4x 10g x 35 woodscrews 30mm(min) penetration

NOTES

- Structural engineer should confirm loading into structure
- Consult TRACKLOK® manual for permissible applications
- Do not bend bracket to suit angle

OVERVIEW

This report outlines the methods that shall be adopted for Specific Engineering Design (SED) for TRACKLOK® bracing systems for non-load bearing internal walls. Design shall be carried out in accordance with B1/VM1 of the New Zealand Building Code. The partition studs and connections are not considered as part of this scope, however need to be considered within the design.

LOADING METHODOLOGY

Loading Standards

The following standards shall be used to determine the design actions on the systems:

- AS/NZS 1170.0:2002 - Structural Design Actions - General Principles
- AS/NZS 1170.2:2011 - Structural Design Actions - Wind Actions
- NZS 1170.5:2004 - Structural Design Actions - Earthquake Actions

Load combinations shall be applied as per AS/NZS 1170.0. ULS design shall be implemented for the bracing elements, and SLS deflection requirements should be considered for items such as the wall studs and headtrack to limit damage of the wall.

Seismic Action Assumptions

NZS 1170.5 - Section 8 shall be used to determine the horizontal and vertical design actions upon the system. The following assumption should be adopted for bracing design:

- Site Subsoil Class C
- Period, $T < 0.75s$
Ceilings/partitions should be designed for $< 0.75s$ to give the most adverse component spectral shape coefficient $C_i(T_p)$ as per Section 8.4 of NZS 1170.5. Hard to determine the period of a suspended ceiling/partition, so have taken the conservative option.
- Near Fault Factor, $N(T,D) = 1.0$
- Ductility, $\mu = 1.0$
- Part Category P.2/P.3 (ULS Design)

Note this is for ULS design as per "Loading Methodology" section in manual. $\mu = 1.0$ as connections/buckling is limiting. AS 4600 has a maximum value of 1.25 and we have taken the conservative option of 1.0 as per 8.7.1 of NZS 1170.5 for non-ductile connections.

Wind Action Assumptions

AS/NZS 1170.2 shall be used to determine the horizontal and vertical design actions upon the system. The following should be adopted for internal walls that do not form a permanent seal:

- Net Pressure Coefficient, $C_{fig} = \pm 0.3$
- Dynamic Response Factor, $C_{dyn} = 1.0$

Note that external walls will have a higher net pressure coefficient and shall be considered as part of specific engineering design.

Live Actions Assumptions

Soft Body Impact as per Table C1 of AS/NZS 1170.0 shall be considered as follows:

- $Q = 0.7kN$

DESIGN METHODOLOGY

Tributary Area

The tributary area method shall be used to determine the bracing demand. The braces are designed to withstand out of plane loads, as shown in Figure 1 below.

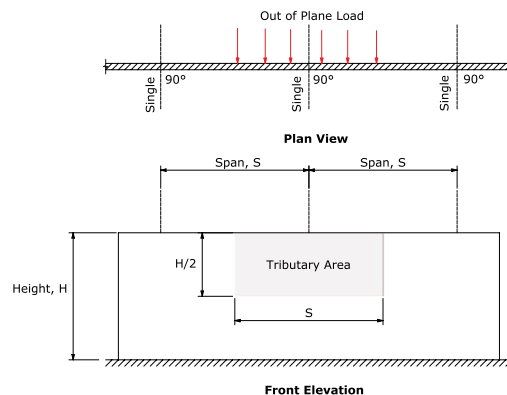

Figure 1 - Tributary area diagram for design

The following assumptions are used:

- The partition wall is sufficiently supported along the floor track
- The partition wall has sufficient shear resistance in plane
- The headtrack and wall studs have sufficient capacity to transfer load between braces

Brace Demand

The bracing demand shall be within the permissible ratings of each TRACKLOK® component. Specific engineering design around studs and structure fixings are permissible, so long as the demand does not exceed the TRACKLOK® ratings. TRACKLOK® components are rated as shown in Figure 2 below. Bracing angles shall be considered to determine loading in other parts of the design.

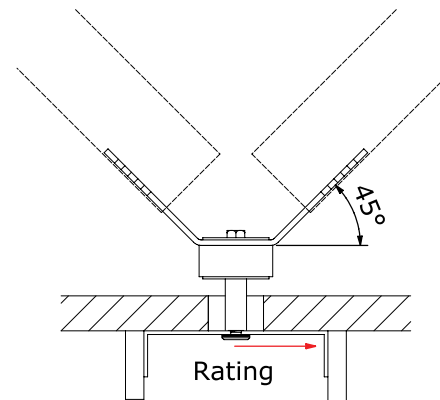

Figure 2 - Illustration of TRACKLOK® component ratings

TRACKLOK® components have the following ratings:

TRACKLOK®	2.37kN
TRACKLOK® RETRO	2.37kN
TRACKLOK® TIMBA	2.37kN
TRACKLOK® FLAT	2.37kN
TRACKLOK® VERT	2.37kN

Table 1 below, shows TRACKLOK® ratings based on plenum height.

DESIGN VERIFICATION

The following standards should be used to validate specific engineering design:

- Steel Studs & Connections: AS/NZS 4600:2005 - Cold-Formed Steel Structure
- Timber Studs & Connections: NZS 3603:1993 - Timber Structures Standard
- Concrete Anchors: NZS 3101:2006 - Concrete Structures Standard

Table 1: Permissible horizontal loads in accordance with AS/NZS 4600

PLENUM HEIGHT MM/	64 OR 92MM X 0.55BMT STUDS*/	64 OR 92MM X 0.55BMT BOXED STUDS*/	64 OR 92MM X 0.75BMT BOXED STUDS*/
0 - 2000	241kgf/2.37kN	241kgf/2.37kN	241kgf/2.37kN
2000 - 3150	-	241kgf/2.37kN	241kgf/2.37kN
3150 - 4000	-	-	241kgf/2.37kN

* Stud to TRACKLOK® connection to consist of 6/10g tek screws.

OVERVIEW

This report outlines the methods that shall be adopted for Specific Engineering Design (SED) for seismic bracing using GRIDLOK® for suspended ceilings. Design shall be carried out in accordance with B1/VM1 of the New Zealand Building Code. Vertical loading and specific suspended ceiling system design is not covered within this scope.

LOADING METHODOLOGY

Loading Standards

The following standards shall be used to determine the design actions on the systems:

- NZS 1170.5:2004 - Structural Design Actions - Earthquake Actions
- AS/NZS 1170.2:2011 - Structural Design Actions - Wind Action
- AS/NZS 2785:2000 - Suspended Ceilings - Design and Install

Load combinations shall be applied as per AS/NZS 2785. ULS design shall be implemented for the bracing elements as per Table 8.1 of NZS 1170.

Seismic Action Assumptions

NZS 1170.5 - Section 8 shall be used to determine the horizontal and vertical design actions upon the system. The following assumption should be adopted for bracing design:

- Site Subsoil Class C
- Period, $T < 0.4s$
- Near Fault Factor, $N(T,D) = 1.0$
- Ductility, $\mu = 1.0$
- Part Category P.2/P.3 (ULS Design)

Wind Action Assumptions

Where the ceiling is raking, lateral restraint will be required to resist wind loads. AS/NZS 1170.2 shall be used to determine the horizontal and vertical design actions upon the system. The following should be adopted for ceilings that do not form a permanent seal:

- Net Pressure Coefficient, $C_{fig} = \pm 0.3$
- Dynamic Response Factor, $C_{dyn} = 1.0$

Note that external ceilings and soffits have a higher net pressure coefficient and shall be considered as part of specific engineering design.

DESIGN METHODOLOGY

Tributary Area

The tributary area method shall be used to determine the bracing demand. The braces are designed to withstand lateral loads, as shown in Figure 1 below. The following assumptions are used:

- A minimum of two braces are used for stability
- All ceiling perimeters are to have a floating connection to allow for inter-story drift
- Maximum ceiling tee lengths to be checked as per manufacturer's requirements
- Vertical suspension as per manufacturer's requirements
- The ceiling behaves as a rigid diaphragm
- Manufacturer seismic requirements are complied with

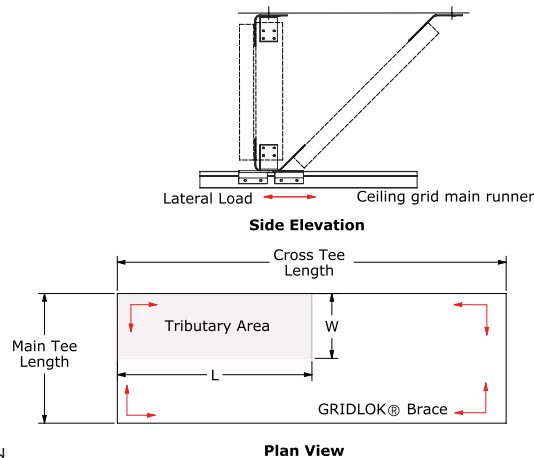

Figure 1 - Tributary area diagram for design

Brace Demand

The bracing demand shall be within the permissible ratings of each GRIDLOK® component. Specific engineering design around studs and structure fixings are permissible, so long as the demand does not exceed the maximum GRIDLOK® rating of 280kgf.

Tributary Area Demand < GRIDLOK® Capacity

Table 1 below, shows GRIDLOK® ratings based on plenum height.

Table 1: Permissible horizontal loads in accordance with AS/NZS 4600

PLENUM HEIGHT MM/	64 X 0.55BMT STUDS*/	92 X 0.75BMT STUDS*/	64 X 0.55BMT BOXED STUDS*/	92 X 0.75BMT BOXED STUDS*/
0 - 600	250kgf/2.45kN	280kgf/2.75kN	250kgf/2.45kN	280kgf/2.75kN
600 - 1000	250kgf/2.45kN	280kgf/2.75kN	250kgf/2.45kN	280kgf/2.75kN
1000 - 1400	250kgf/2.45kN	280kgf/2.75kN	250kgf/2.45kN	280kgf/2.75kN
1400 - 1800	160kgf/1.57kN	270kgf/2.65kN	250kgf/2.45kN	280kgf/2.75kN
1800 - 2200	110kgf/1.07kN	180kgf/1.77kN	250kgf/2.45kN	280kgf/2.75kN
2200 -2600	80kgf/.78kN	130kgf/1.27kN	250kgf/2.45kN	280kgf/2.75kN
2600 - 3000	60kgf/.58kN	100kgf/.98kN	190kgf/1.86kN	280kgf/2.75kN
3000 - 3500	-	-	140kgf/1.37kN	280kgf/2.75kN
3500 - 4000	-	-	100kgf/.98kN	210kgf/2.05kN

* Stud to GRIDLOK® connection to consist of 4/10g tek screws

TRACKLOK® INSTALLATION/

Must be installed in accordance with manufacturers specification and within the parameters of AS/NZS1170.5. Install sheets are available online and in every box of TRACKLOK® | TRACKLOK® RETRO | TRACKLOK® TIMBA | TRACKLOK® VERT | TRACKLOK® FLAT. Partition walls must be installed as per manufacturers recommendation. Create a minimum clearance of 10mm from unit to ceiling tile and/or grid. Installation at centres and configurations as referenced in set out sheets. Set out sheets cover standard partitioning requirements; construction outside of available set out sheet information will require consultation and approval. Approved seismic fixings to be used for attachment to structure over. Architect and/or Structural Engineer and relevant regulatory bodies must approve variations of installation. Bracing material must be fixed with 10-gauge drill point wafer head tek screws. Steel bracing material must be as per plenum height charts or as designed by engineer. Although all aluminium head track with a material thickness of 1.3mm – 1.8mm is acceptable for use, we do not take responsibility or liability for performance of, or installation of partition or glazing head track. Use of .55BMT steel track, as head section is not permitted under this specification. Installation is required 100mm – 300mm from the end of blade walls. T section walls are deemed self-supporting requiring unit to be placed at distance specified by the set out sheets. The unit must not be deformed or altered in any way. Ceiling void heights over 2.0 meters require stud bracing to be boxed. Continuous head track over door requires unit to be installed on latch side, broken head track over door requires units to be installed on latch side and hinge side. Tenancy changes requiring walls to be moved require new units to be installed.

LIMITATIONS/

For interior application only. Designed to secure standard steel, aluminium and timber partition walls and glazed walls. Not applicable for supporting walls constructed from concrete, tilt slab or block. Structural engineer and regulatory body must seismically approve configurations outside of specifications. The unit and or bracing material must not be used as an anchor point or fixing point by associated trades. Use of this product does not increase the seismic load capacity of installed ceiling grid.

GRIDLOK® INSTALLATION/

Must be installed in accordance with manufacturers specification and within the parameters of AS/NZS1170.5 AS/NZS4219 AS/NZS2785. Install sheets are available online and in every box of GRIDLOK®. Ceilings must be installed as per manufacturers recommendation. Installation at centres and configurations as referenced by ceiling designers, ceiling manufacturers recommendations given GRIDLOK® capacity. Construction outside of available information will require consultation and approval. Approved seismic fixings to be used for attachment to structure over. Architect and / or structural engineer plus relevant regulatory bodies must approve variations of installation. Bracing material must be fixed with 10-gauge drill point wafer head tek screws. Steel bracing material must be 64mm .55 BMT, .75 BMT or 1.15 BMT or 92mm .55 BMT, .75 BMT or 1.15 BMT. All GRIDLOK® units and bracing must be checked after seismic event for signs of wear. GRIDLOK® is not intended to replace ceiling suspension wires, which must be installed as per manufacturers specification. Although all ceiling grid is acceptable for use we do not take responsibility or liability for performance of, or installation of ceiling grid. The unit must not be deformed or altered in any way. Tenancy changes requiring new ceiling installation requires new GRIDLOK® units to be installed.

LIMITATIONS/

For interior application only. Structural engineer and regulatory body must seismically approve configurations outside of specifications. The unit and / or bracing material must not be used as an anchor point or fixing point by associated trades.

NOTICE/

We shall not be liable for incidental and consequential damages, directly or indirectly sustained, nor for any loss caused by application of these goods not in accordance with current printed instructions or for other than intended use. Our liability is expressly limited to replacement of defective goods. Any claim shall be deemed waived unless made in writing to us within thirty (30) days from the date it was or reasonably should have been discovered.

The information presented is correct to the best of our knowledge at the date of issuance. Because codes continue to evolve, check with a local official prior to designing and installing. Other restrictions and exemptions may apply.



Available From
POTTER
INTERIOR SYSTEMS

TECH SUPPORT
Ph +64 21 170 8734
plans@tracklok.com

TRACKLOK Ltd
PO BOX 31270
Milford
Auckland 0620

www.tracklok.com