

SECTION 04 | INTRODUCING SOUNDDOWN™ ENDURABASE™

SoundDown™ offer pre-assembled, acoustically isolated shower modules to compliment SoundDown™ PAB acoustic floor systems. A two part system consisting of a customisable Sub-Base and either a fixed or flex preformed tileable tray. The following systems remove the need to build up the shower floor with wet screeds that reduces on-site labour and enables a seamless, flush shower entry whilst guaranteeing code compliant floor falls.

SoundDown™ Endurabase™ Fixed and Flex | A seamless pre-fabricated solution for showers

A complimentary system to SoundDown™ PAB™ Acoustic Floor System

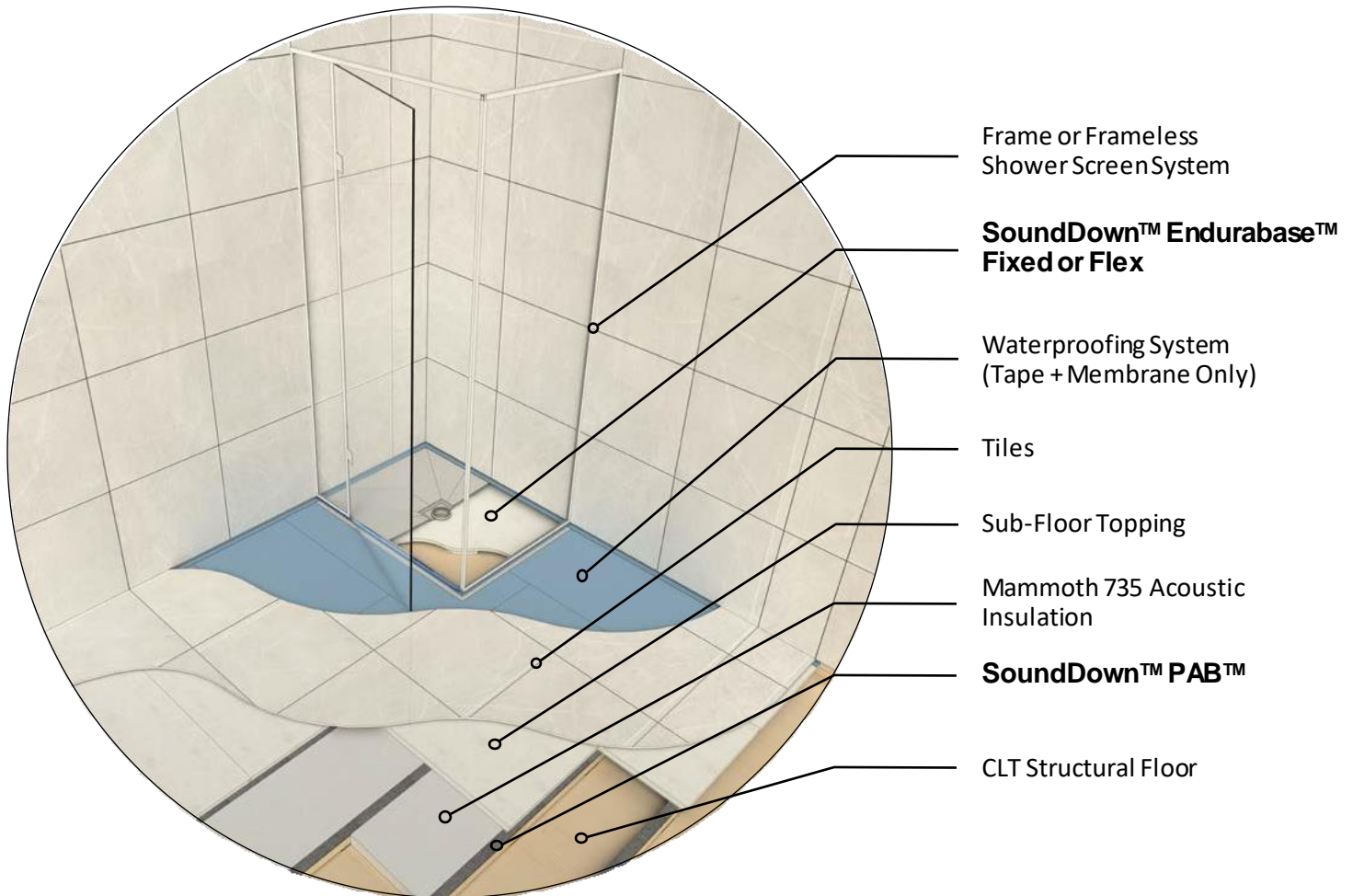

SoundDown™ Endurabase™ Fixed and Flex

- Designed for premium architectural bathrooms with walk-in, corner, alcove and truncated layouts
- 100% waterproof shower base systems
- Hobless design; flush, level entry
- Standard and custom sizes, made to order
- High precision manufacture, guarantee perfect fit
- Channel drain and centre drain options
- Pre-formed code compliant fall guarantees drainage
- Easy and fast to waterproof and tile
- Removal of wetscreeds and mortar bases
- Peace of mind, backed by SoundDown™ Warranty



SECTION 04 | INTRODUCING SOUNDDOWN™ ENDURABASE™

SoundDown™ Seamless Shower and Acoustic Floor Systems

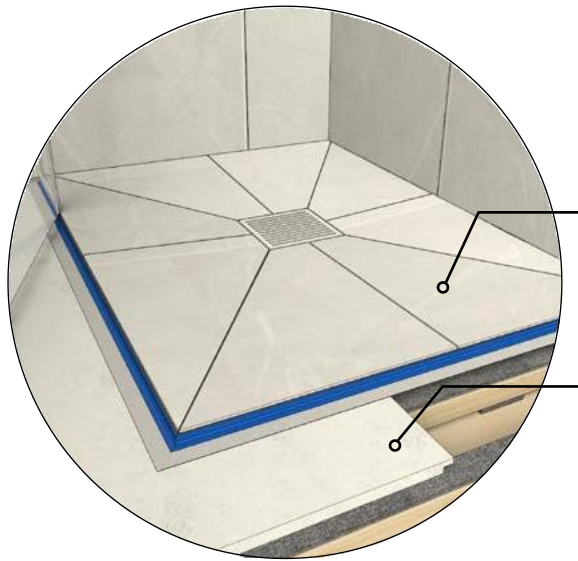

SoundDown™ Endurabase™ Fixed or Flex
Pre-fabricated shower solution

SoundDown™ PAB or SDP
Acoustic Floor System

System Information

Height Range:	42 to 350mm
In-Built Floor Waste:	✓
Top Durability: Maglok or FC	✓
No Wet Screed:	✓
Seamless Floor Transition:	✓
In-Built Code Compliant Fall:	✓
Versatile, Custom Sizes:	✓
Suits All Layout Shapes:	✓
Fast & Easy Installation:	✓
Impact Sound Absorbing: Flex	✓
Dimensionally Stable:	✓

1 | SoundDown™ Endurabase™ Fixed Fibreglass Tray

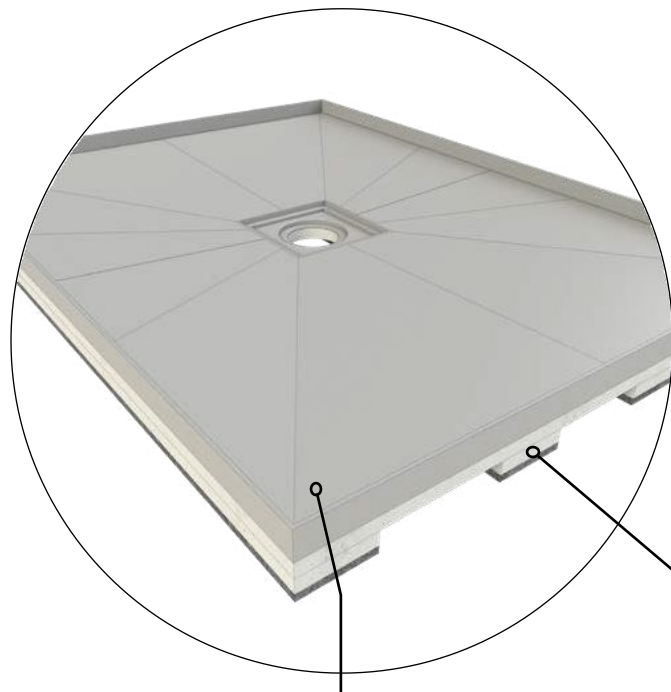

SoundDown™ Fixed
Pre-Formed Fibreglass Shower Tray

2 | SoundDown™ Endurabase™ Flex Cement coated, XPS-Core Base

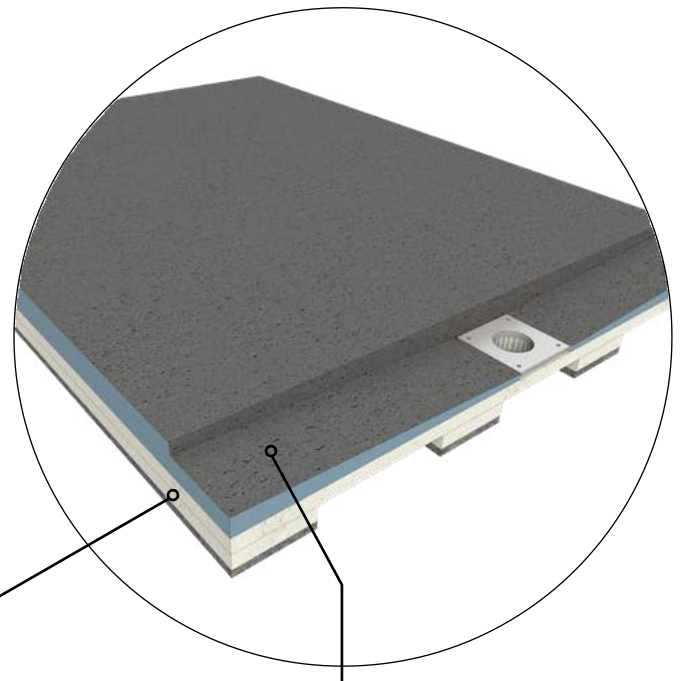

SoundDown™ Flex
Pre-Formed cement coated XPS-core Shower Base

SoundDown™ Endurabase™ Sub-Base
Pre-fabricated acoustically-isolated, moisture-resistant base

Available Sizes

1000 x 1000mm
1200 x 900mm
1400 x 900mm
1600 x 900mm
1800 x 900mm

Product Information

Standard Shower Size Options
Centre Drain Configuration
Easyclean Drain Waste
Rated for up to 300kg
Square Corner & Alcove Shapes

Product Information

Custom designed to suit your shower shape and size
Can be cut on-site to allow for as built tolerances
Maximum 2400mm length available
Minimum height at lowest point; 18mm
Convenient & simple pre-formed shower niches available

Contact your SoundDown™ representative for project specific design and installation support.

SECTION 05 | SYSTEM COMPONENTS

Table 1 | Main Components | Supplied by Build Anatomy







Category	Products	Switch
SoundDown™ Pre-Fabricated Floor Products	SoundDown™ PAB <i>A pre-assembled acoustic batten comprising of LVL & recycled rubber isolation strips, typical size 42x46mm (custom profile sizes available) Available in 1.0m, 1.8m, 2.4m & 3.0m lengths.</i>	
	SoundDown™ PAB Fire Block <i>A pre-assembled, fire-stopping acoustic batten comprised of LVL & recycled rubber isolation strips encapsulated in 16mm FR plasterboard to prevent to spread of fire within the sub-floor; specifically designed for floor fire compartmentalisation. Available in 1.0m lengths.</i>	
	SoundDown™ SDP <i>A pre-assembled acoustic sandwich panel comprising of Maglok Dragonboard 20mm, recycled rubber isolation strips and pads and 6mm SaveBoard Exposed Internal Lining. Available in 1800x600x42mm.</i>	
SoundDown™ Pre-Fabricated Shower Modules	SoundDown™ Endurabase™ Fixed <i>A pre-assembled, acoustically isolated, preformed fibreglass shower tray mounted on a moisture-resistant Maglok Dragonboard 40mm base ready for waterproofing and tiling. A perfect option for a standardised approach to showers. Available in 1000x1000mm, 1200x900mm, 1400x900mm, 1600x900mm & 1800x900mm.</i>	
	SoundDown™ Endurabase™ Flex <i>A pre-assembled, acoustically isolated, preformed polymer cement coated XPS-core shower base mounted on a moisture-resistant Maglok Dragonboard base ready for waterproofing and tiling. Available in custom sizes up to 2400mm long and 1000x1000mm, 1200x900mm, 1400x900mm, 1600x900mm & 1800x900mm.</i>	
Sub-Floor Topping	Maglok™ Dragonboard 20mm <i>A chloride-free, fibre-reinforced MgO board for use as structural sub-floor featuring a shiplap joint on the long edge. Available sizes: - 2000x1200mm and 1800x1200mm. *1800x1200x20mm is preferred for SoundDown™ PAB due to fitting batten spacing efficiency gain.</i>	
	BGC Fibre Cement <i>A cellulose-reinforced cement sheet for use as a structural sub-floor featuring a tongue and groove joint on the long edge. Available products and sizes: - Innova™ Durafloor™ 19mm: 2250x600mm & 2700x600mm. - Innova™ Durafloor™ 22mm: 2400x600mm. - Compressed Flooring 15mm: 2400x1200mm. - Compressed Flooring 18mm: 1800x1200mm & 2400x1200mm. *Compressed Flooring 24mm available by order only. Confirm availability with BGC Fibre Cement.</i>	
	ISB™ EUROfloor or Laminex™ Strandfloor® (OSB) <i>A oriented strand board (OSB) for use as a structural sub-floor featuring a tongue and groove joint on the long edge. Available products and sizes: - Laminex Strandfloor T&G. Available in 2400x1200x20mm & 3600x1200x20mm. - ISB™ EUROfloor 20mm Available in 2400x1200x20mm & 3600x1200x20mm. *Wet areas: a moisture-resistant OSB is required. H3.1 grade or higher with Stainless Steel fasteners (SS304 or SS316).</i>	
Insulation	Mammoth™ Acoustic 735 <i>A 735gsm, 14.7kg/m³, moisture-resistant, non-sag, polyester insulation available in blankets and sections. Available in 405mm or 360mm wide rolls (20m² per pack).</i>	

Table 2 | Accessories | Supplied by Build Anatomy

Category	Products	Switch
Spare Parts	SoundDown™ SDP Acoustic Isolation Kit <i>A kit of additional isolation strips and pads to reinforce SoundDown™ SDP panels where cutting has removed pre-assembled isolation material.</i>	
Screws	Screws <i>10G x 50mm Countersunk (CSK) Self-Tapping Collated Screws. OSB Topping: Min. Zinc Coated or SS304 where treated to H3 or above. Maglok™ or BGC Fibre Cement: Min. Class 3 Galvanised.</i>	
Construction Adhesive	Construction Adhesive <i>Examples: Sika™ Nail Bond Premium, Holdfast Gorilla™ Grip, Bostik™ Alpha Grip & Selleys™ Liquid Nails *Only required for Maglok Dragon Board lap joints.</i>	
Fire & Acoustic Sealant	Fire & Acoustic Sealant <i>Examples: Selleys Superfire 810 or similar</i>	

 Denotes interchangeability of products permitted when a professional acoustician, fire engineer or manufacturer has provided a technical specification suitable for your project needs.