

PLAN SCALE 1:10

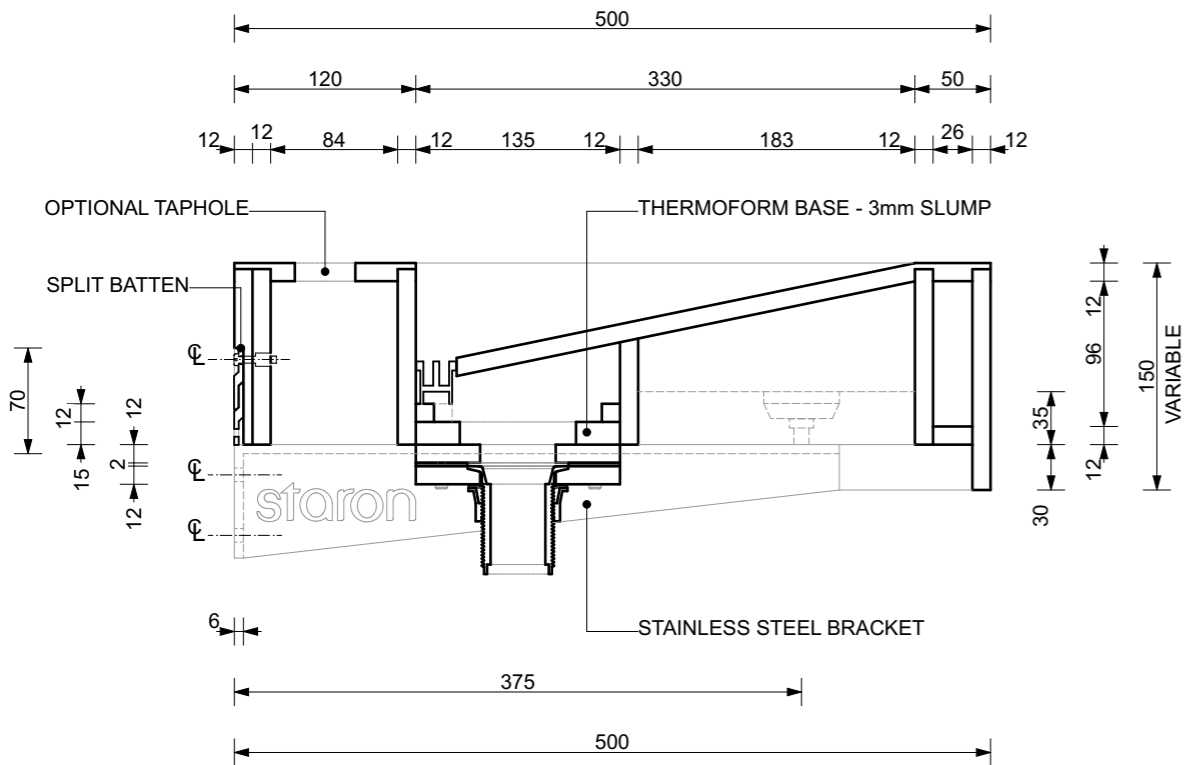

SECTION 1:5

OPTIONAL STARON SUPPLIED COMPONENTS

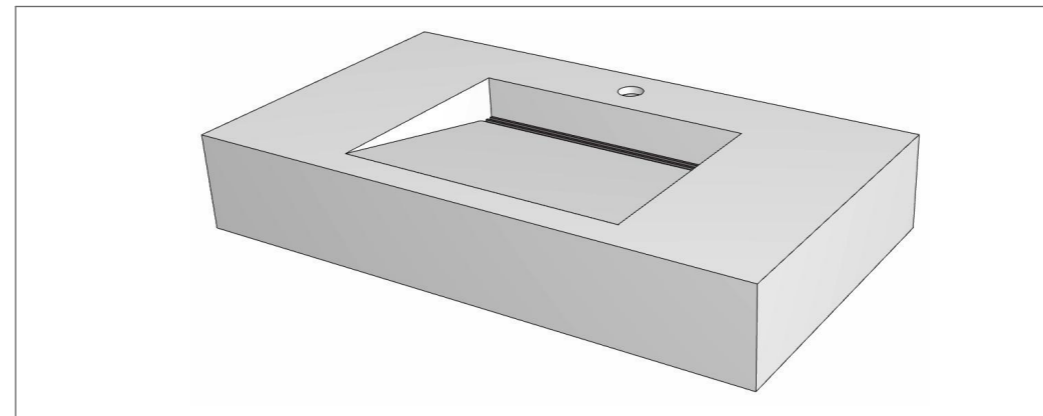
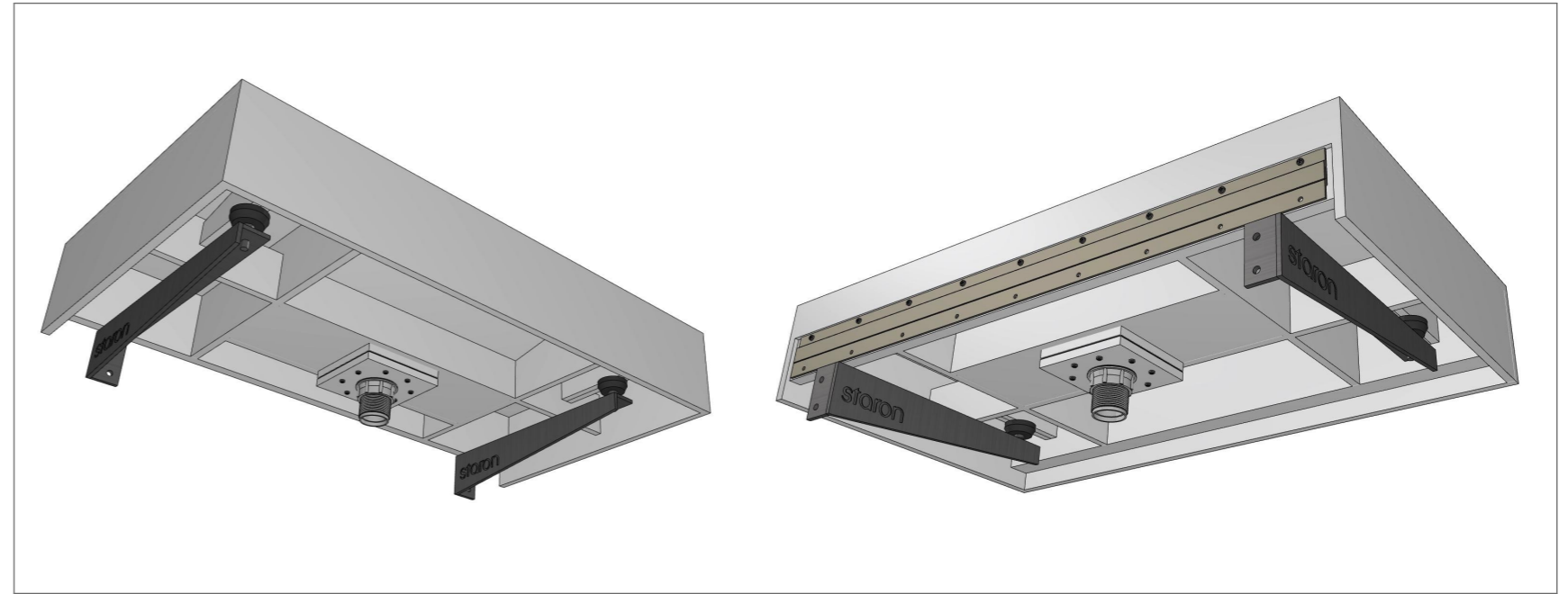
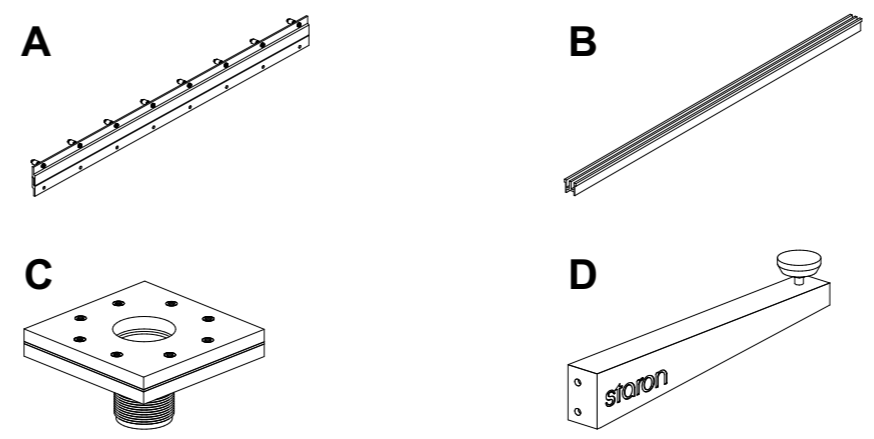

- A** STAINLESS STEEL SPLIT BATTEN - For securing washplane to wall
- B** ALUMINIUM GRATE - Aids easy cleaning and prevents jewellery loss
- C** WASTE OUTLET ASSEMBLY - Simple disassembly allows plumbing access
- D** STAINLESS STEEL BRACKET - Each bracket provides 100kg support

SPECIFICATION DETAILS

- Australian designed
- Fabricated in every state
- STARON
- 2/3 natural mineral and 1/3 acrylic
Silica and polyester free
Greenguard & Greenguard Gold certified
10 Year Warranty
- Unit available in all Staron colours including mixed combinations
- Aluminium grate supplied in
satin silver grey
satin black
mill finish (allowing further custom anodising / powder coating)
- All dimensions flexible
- Adapt design to suit joinery units
- Modify form to accommodate:
disability rails
parcel shelves
towel / soap dispensers
tapware
- Height to be confirmed by Architect / Designer

FABRICATION & INSTALLATION

- Manufacture as per fabrication requirements
- 1 waste outlet for every sink
- Weight of unit approx 40kg per lineal metre
- Builder to ensure suitable wall strength to support

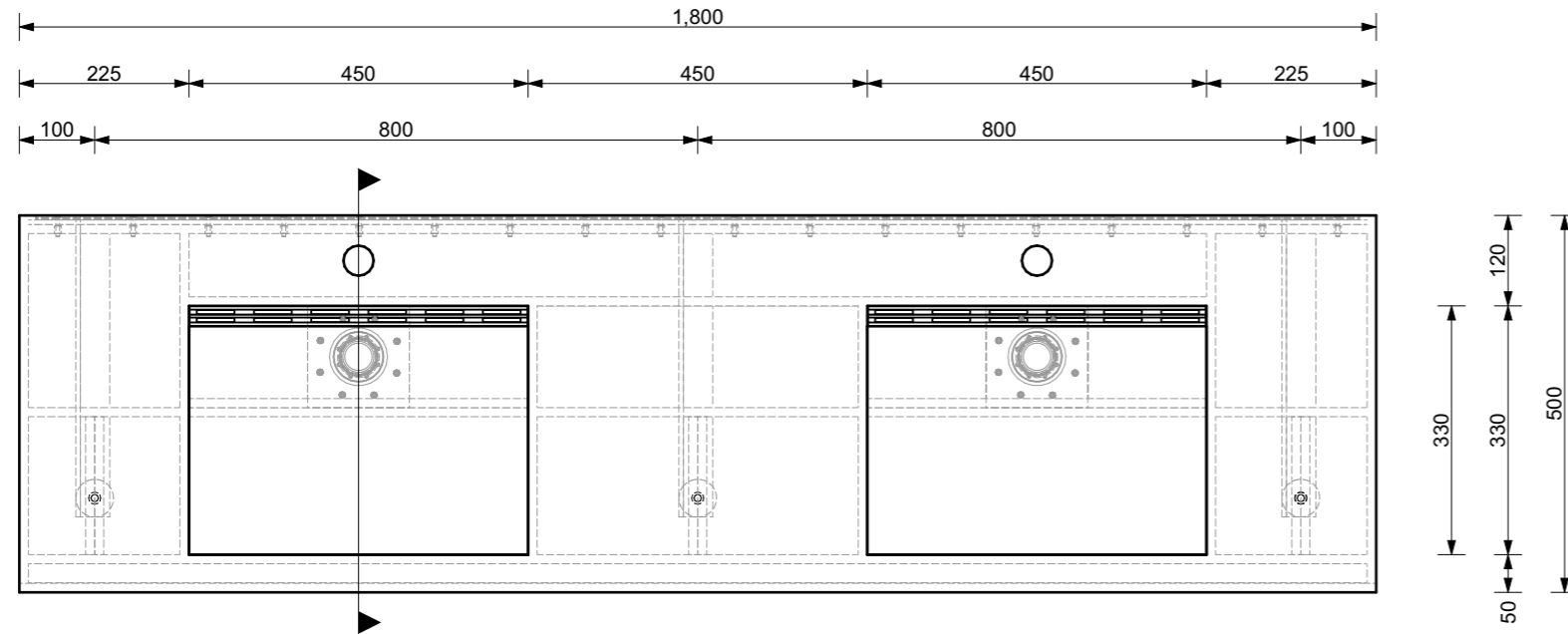

PLAN SCALE 1:10

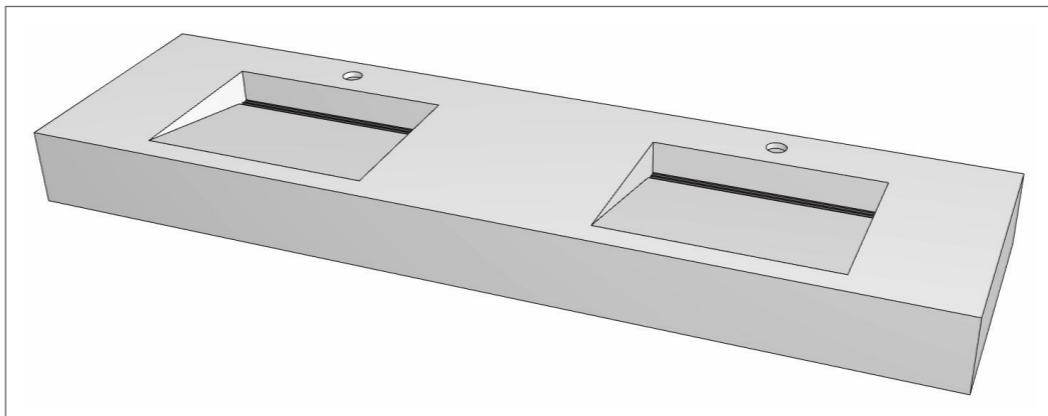

OPTIONAL STARON SUPPLIED COMPONENTS

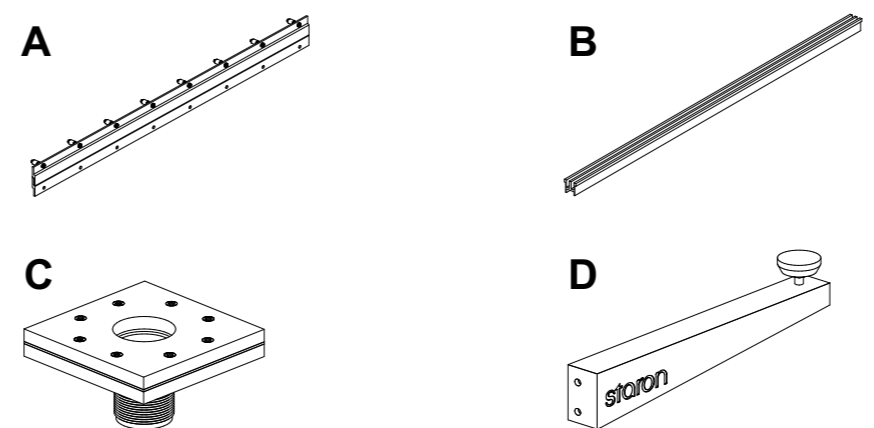

- A** STAINLESS STEEL SPLIT BATTEN - For securing washplane to wall
- B** ALUMINIUM GRATE - Aids easy cleaning and prevents jewellery loss
- C** WASTE OUTLET ASSEMBLY - Simple disassembly allows plumbing access
- D** STAINLESS STEEL BRACKET - Each bracket provides 100kg support

SPECIFICATION DETAILS

- Australian designed
- Fabricated in every state
- STARON
 - 2/3 natural mineral and 1/3 acrylic
 - Silica and polyester free
 - Greenguard & Greenguard Gold certified
 - 10 Year Warranty
- Unit available in all Staron colours including mixed combinations
- Aluminium grate supplied in
 - satin silver grey
 - satin black
 - mill finish (allowing further custom anodising / powder coating)
- All dimensions flexible
- Adapt design to suit joinery units
- Modify form to accommodate:
 - disability rails
 - parcel shelves
 - towel / soap dispensers
 - tapware
- Height to be confirmed by Architect / Designer

FABRICATION & INSTALLATION

- Manufacture as per fabrication requirements
- 1 waste outlet for every sink
- Weight of unit approx 40kg per lineal metre
- Builder to ensure suitable wall strength to support

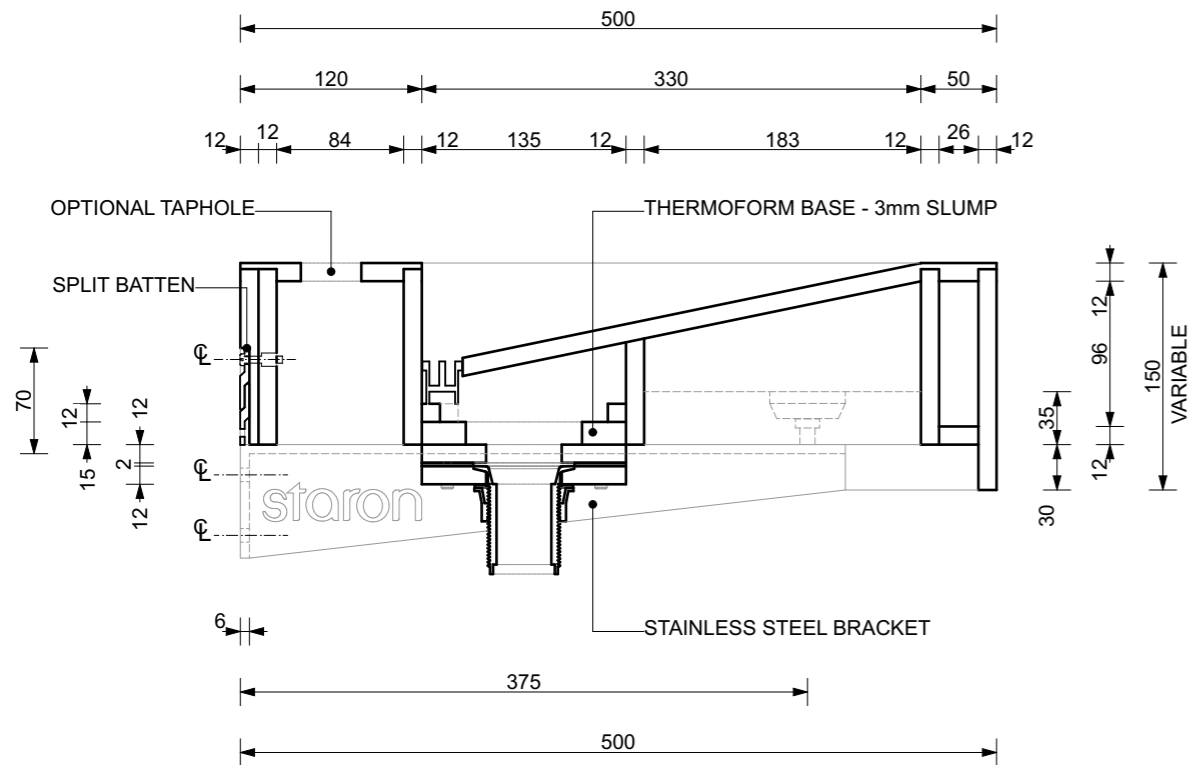

SECTION 1:5

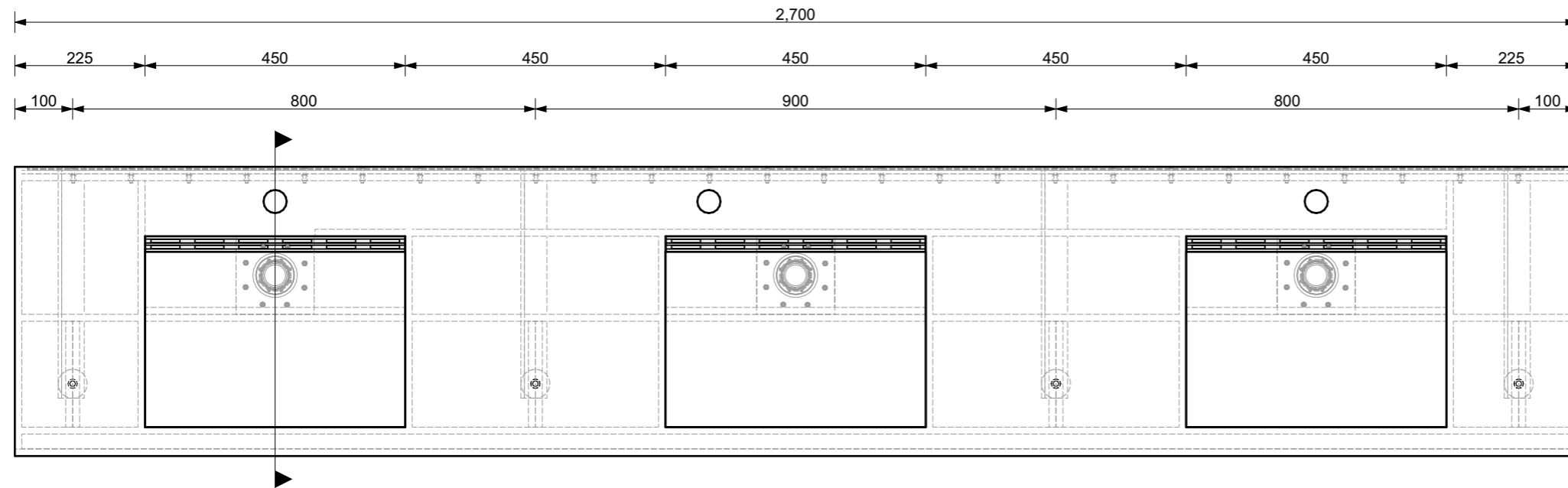

PLAN SCALE 1:10

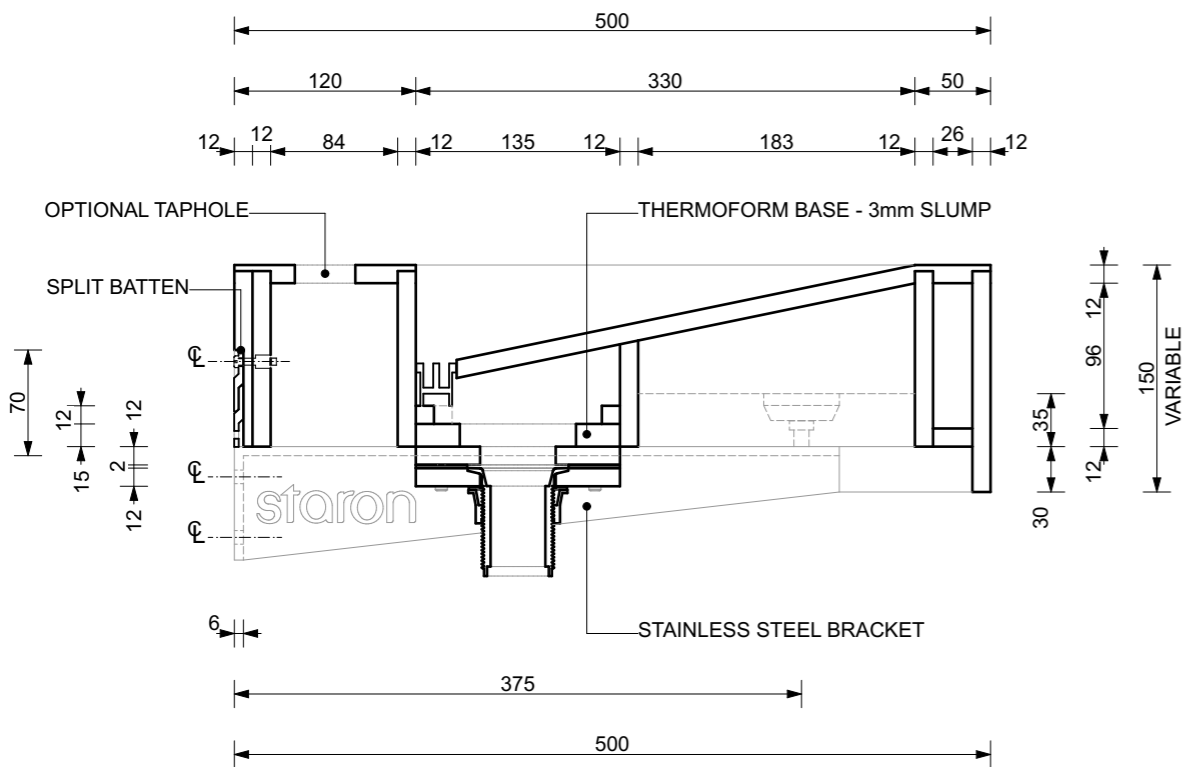

SECTION 1:5

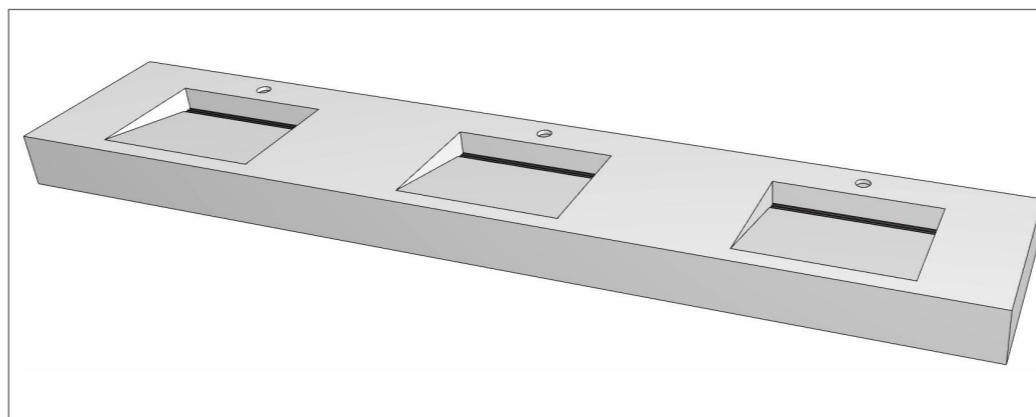

OPTIONAL STARON SUPPLIED COMPONENTS

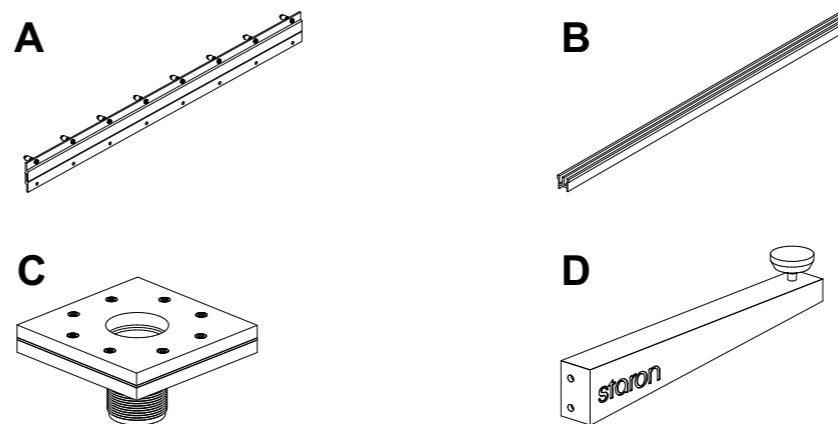

- A** STAINLESS STEEL SPLIT BATTEN - For securing washplane to wall
- B** ALUMINIUM GRATE - Aids easy cleaning and prevents jewellery loss
- C** WASTE OUTLET ASSEMBLY - Simple disassembly allows plumbing access
- D** STAINLESS STEEL BRACKET - Each bracket provides 100kg support

SPECIFICATION DETAILS

- Australian designed
- Fabricated in every state
- STARON
 - 2/3 natural mineral and 1/3 acrylic
 - Silica and polyester free
 - Greenguard & Greenguard Gold certified
 - 10 Year Warranty
- Unit available in all Staron colours including mixed combinations
- Aluminium grate supplied in
 - satin silver grey
 - satin black
 - mill finish (allowing further custom anodising / powder coating)
- All dimensions flexible
- Adapt design to suit joinery units
- Modify form to accommodate:
 - disability rails
 - parcel shelves
 - towel / soap dispensers
 - tapware
- Height to be confirmed by Architect / Designer

FABRICATION & INSTALLATION

- Manufacture as per fabrication requirements
- 1 waste outlet for every sink
- Weight of unit approx 40kg per lineal metre
- Builder to ensure suitable wall strength to support

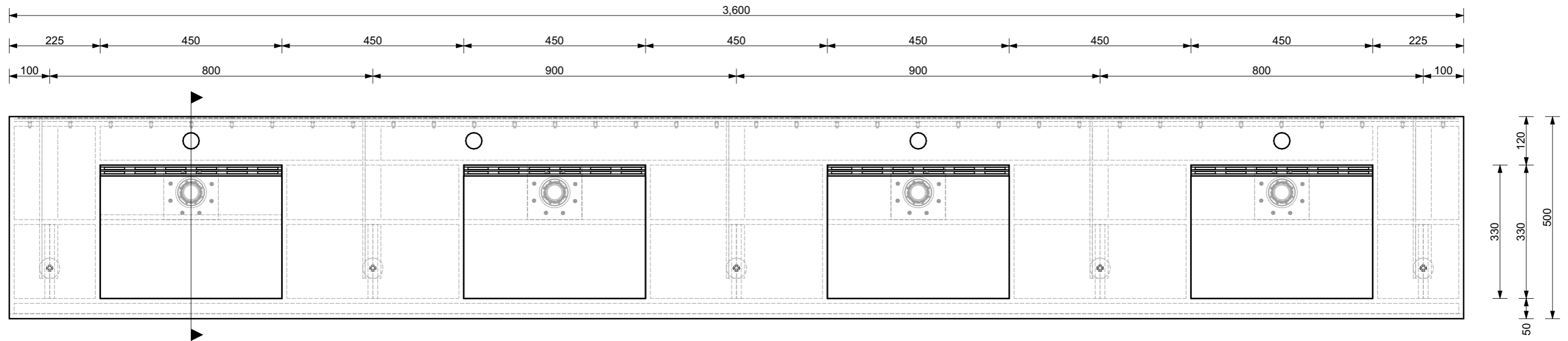

PLAN SCALE 1:10

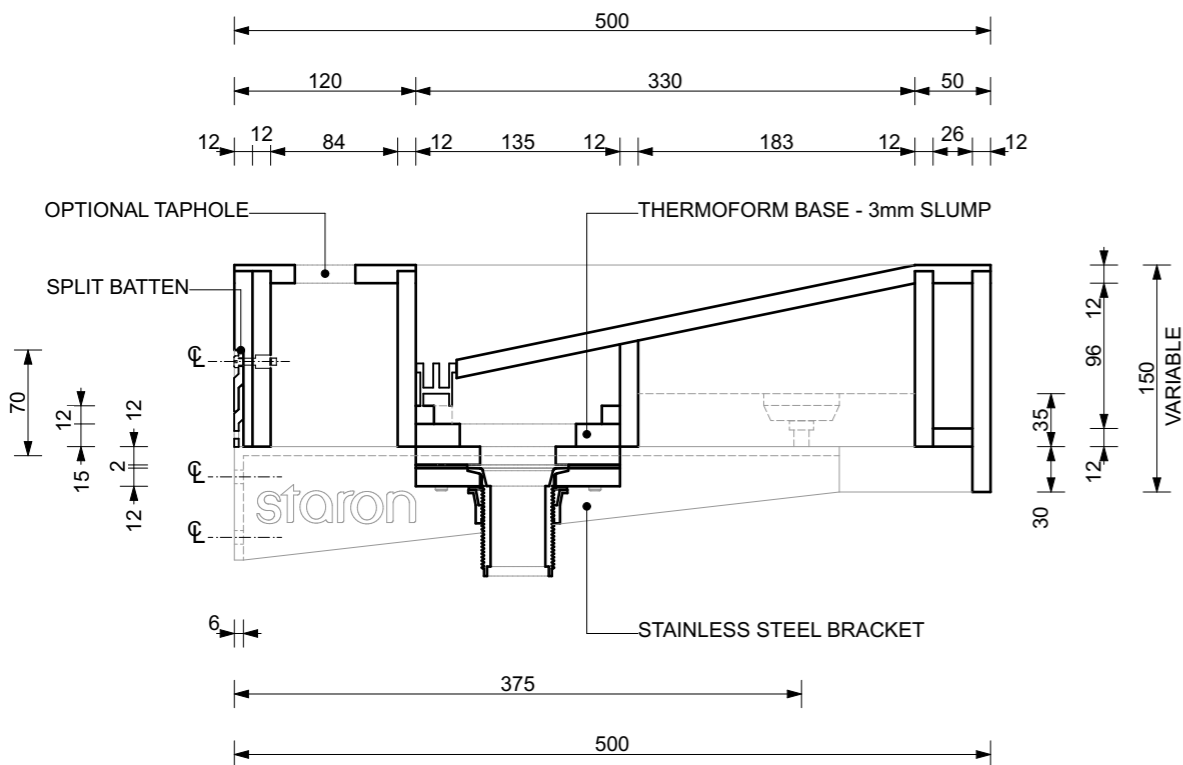

SECTION 1:5

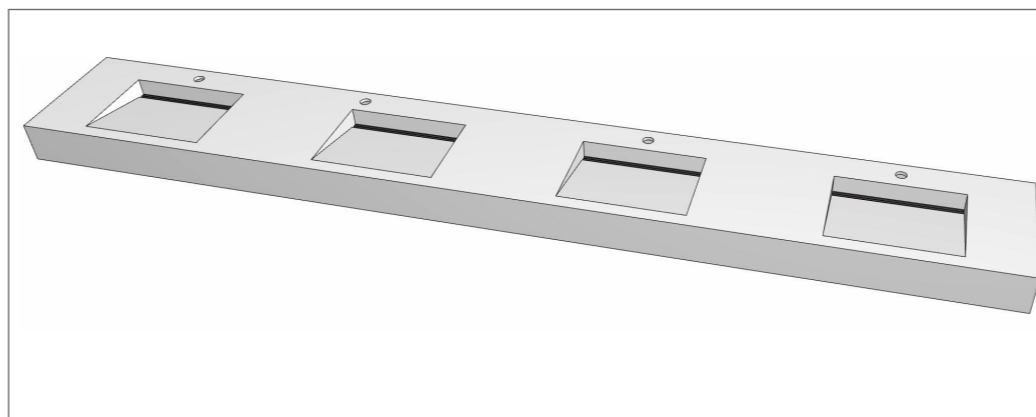

OPTIONAL STARON SUPPLIED COMPONENTS

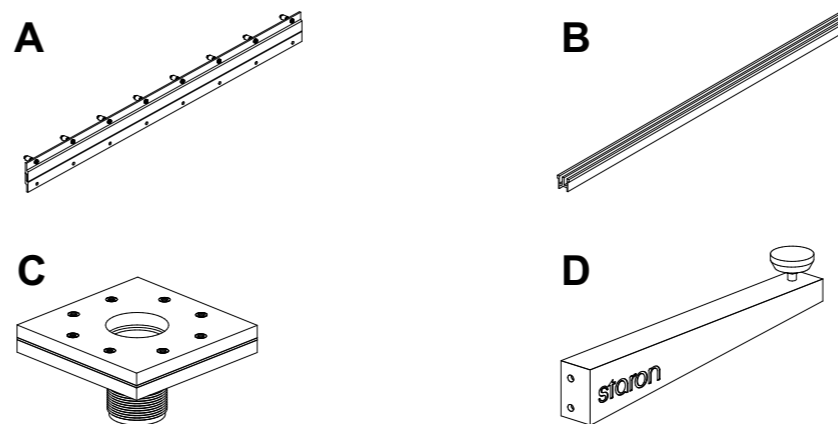

- A** STAINLESS STEEL SPLIT BATTEN - For securing washplane to wall
- B** ALUMINIUM GRATE - Aids easy cleaning and prevents jewellery loss
- C** WASTE OUTLET ASSEMBLY - Simple disassembly allows plumbing access
- D** STAINLESS STEEL BRACKET - Each bracket provides 100kg support

SPECIFICATION DETAILS

- Australian designed
- Fabricated in every state
- STARON
 - 2/3 natural mineral and 1/3 acrylic
 - Silica and polyester free
 - Greenguard & Greenguard Gold certified
 - 10 Year Warranty
- Unit available in all Staron colours including mixed combinations
- Aluminium grate supplied in
 - satin silver grey
 - satin black
 - mill finish (allowing further custom anodising / powder coating)
- All dimensions flexible
- Adapt design to suit joinery units
- Modify form to accommodate:
 - disability rails
 - parcel shelves
 - towel / soap dispensers
 - tapware
- Height to be confirmed by Architect / Designer

FABRICATION & INSTALLATION

- Manufacture as per fabrication requirements
- 1 waste outlet for every sink
- Weight of unit approx 40kg per lineal metre
- Builder to ensure suitable wall strength to support

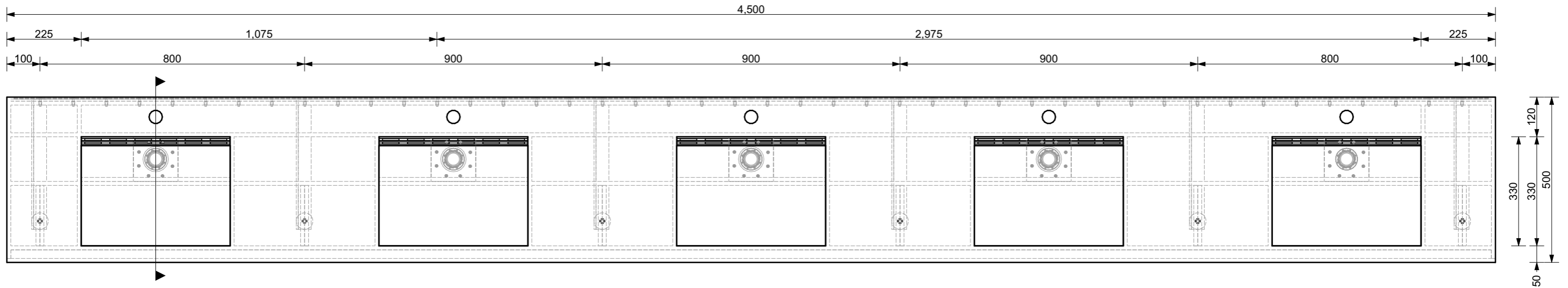

PLAN SCALE 1:12

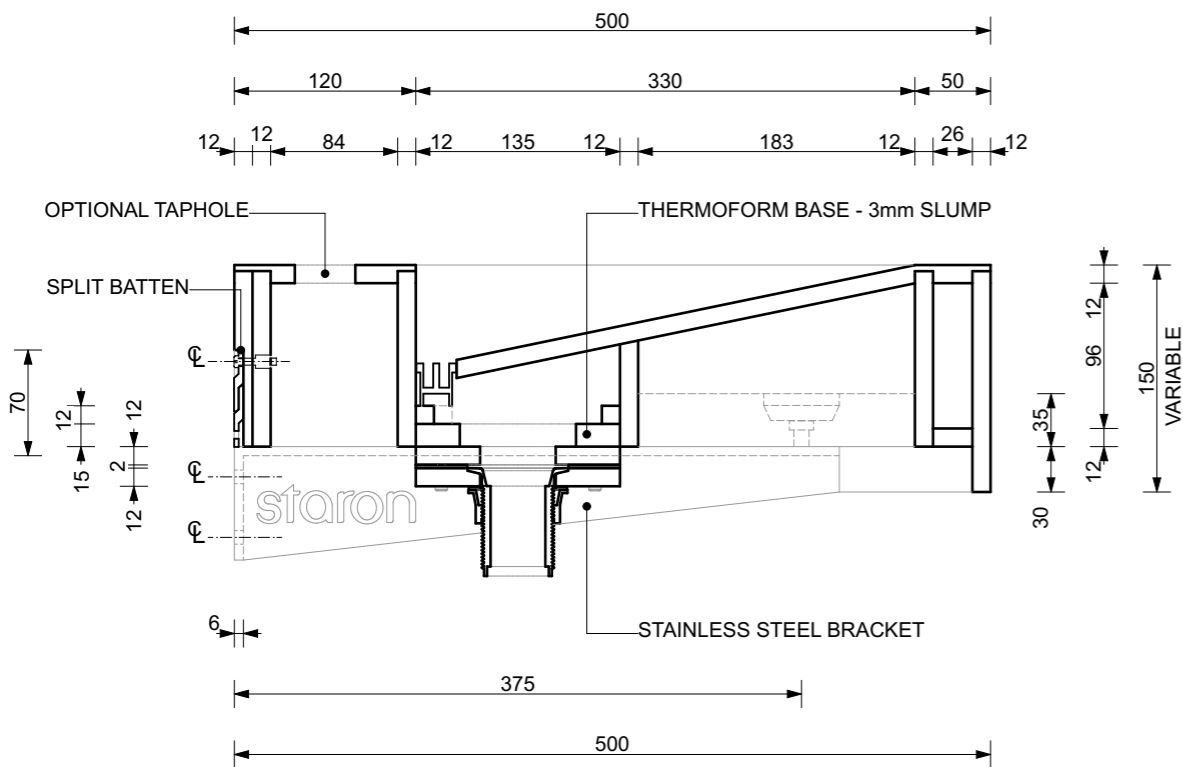

SECTION 1:5

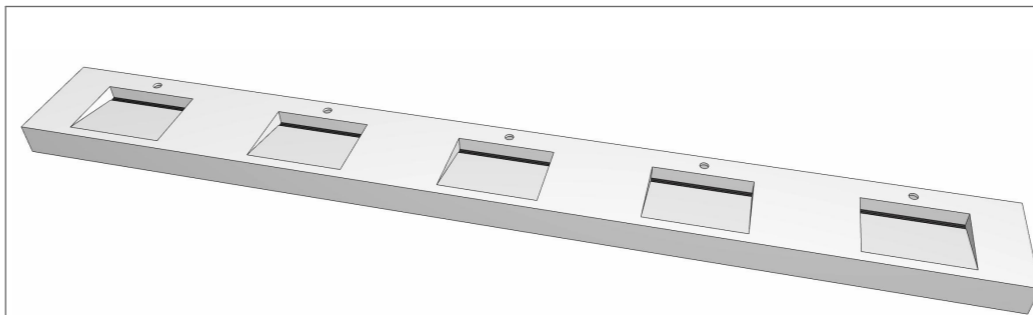

OPTIONAL STARON SUPPLIED COMPONENTS

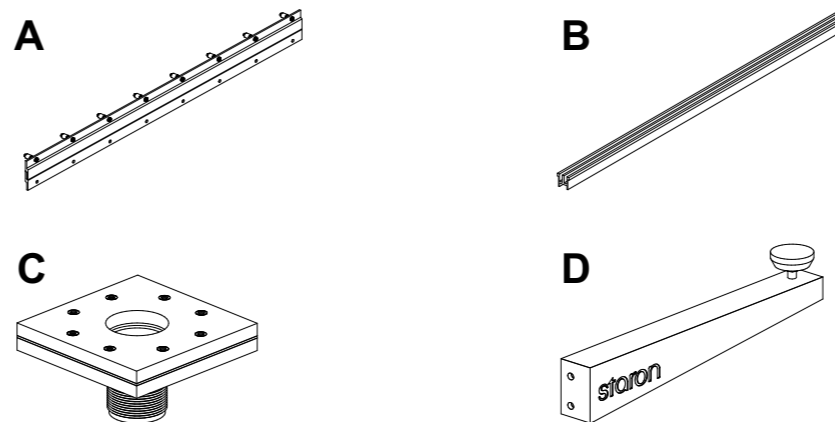

- A** STAINLESS STEEL SPLIT BATTEN - For securing washplane to wall
- B** ALUMINIUM GRATE - Aids easy cleaning and prevents jewellery loss
- C** WASTE OUTLET ASSEMBLY - Simple disassembly allows plumbing access
- D** STAINLESS STEEL BRACKET - Each bracket provides 100kg support

SPECIFICATION DETAILS

- Australian designed
- Fabricated in every state
- STARON
 - 2/3 natural mineral and 1/3 acrylic
 - Silica and polyester free
 - Greenguard & Greenguard Gold certified
 - 10 Year Warranty
- Unit available in all Staron colours including mixed combinations
- Aluminium grate supplied in
 - satin silver grey
 - satin black
 - mill finish (allowing further custom anodising / powder coating)
- All dimensions flexible
- Adapt design to suit joinery units
- Modify form to accommodate:
 - disability rails
 - parcel shelves
 - towel / soap dispensers
 - tapware
- Height to be confirmed by Architect / Designer

FABRICATION & INSTALLATION

- Manufacture as per fabrication requirements
- 1 waste outlet for every sink
- Weight of unit approx 40kg per lineal metre
- Builder to ensure suitable wall strength to support