

COLORSTEEL®
Design Guide

TRANSFORMING ENVIRONMENTS





COLORSTEEL® Cloud, Corrugate Profile
Hillside Habitats, Aro Valley



COLORSTEEL® is made, tested and trusted for New Zealand conditions

For over 40 years, COLORSTEEL® has been helping New Zealanders transform their environments. Driven by a desire to create better, stronger and more beautiful every day, we are constantly building on our foundation of practical knowledge, experience and understanding to think differently and deliver intelligent solutions for real applications.

At COLORSTEEL® we conduct both accelerated testing and real time testing. With over 20,000 test samples in the field at any one time you can rest assured that our products are robust and will stand the test of time. The accelerated testing provides us with information on the durability of our products while the real time testing proves the performance of COLORSTEEL® will be replicated in the built environment.

Over its many years, COLORSTEEL® has become a household name in New Zealand. Consequently, it's sometimes used as a generic term to describe 'coloured steel'. It's for this reason that it's important to ensure you insist on genuine COLORSTEEL® for your project.

The following guide outlines the critical elements that need to be considered when designing with COLORSTEEL®.



COLORSTEEL® Solutions

COLORSTEEL® – designed, tested and approved to stand up to New Zealand’s unique environments and become a part of them.

Environmental factors unique to location play an important part in determining the best solution for your project.

For recommendations on which COLORSTEEL® solution is best for your project contact us at specifications@colorsteel.co.nz and we can help advise the solution that’s right for you.



COLORSTEEL® Sandstone Grey, Trapezoidal Profile
Harrex Residence, Alexandra Airport



COLORSTEEL® Ultimate® in FlaxPod®, Trapezoidal Profile
Onemana Surf Club, Coromandel

Special Environments

In New Zealand there are areas where local conditions create an increased likelihood of corrosion. Special consideration should be given to material selection in these areas. If you think your project may experience one of the following environments, please contact New Zealand Steel, or your supplier, for advice about the best COLORSTEEL® product to use.

GEOTHERMAL AREAS

Sulphuric compounds associated with geothermal activity create a corrosive environment. Variations in natural activity or draw-off from steam bores plus the effects of weather conditions make the high-risk areas hard to define.

HIGH HUMIDITY INTERNAL ENVIRONMENTS

Processing plants and enclosed swimming pools can create an environment with high humidity which requires special consideration for material selection and maintenance.

HARSH INTERNAL ENVIRONMENTS

Some commercial or agricultural applications may create internal environments in which the build-up of pollutants or fumes is a potential source of corrosion. Sheds for intensive animal farming can create a particularly aggressive internal environment.

INDUSTRIAL ENVIRONMENTS

Environments close to corrosive industrial emissions that may be subject to heavy fallout require extra consideration.

Introducing the Next Generation

NEW COLORSTEEL® MAXAM™

Superior protection for Mild inland environments to Very Severe coastal environments



Bringing together the outstanding quality and consistency COLORSTEEL® is known for, with game changing Activate™ technology, designed to deliver enhanced corrosion resistance. One solution suitable for most New Zealand environments, providing exceptional durability and corrosion protection, from alpine regions to urban city centres.

COLORSTEEL® ALTIMATE®

Ultimate protection for Extremely Severe marine and breaking surf environments



Combines a marine grade aluminium substrate with the proven paint technology of COLORSTEEL®, designed for superior corrosion protection within our most extreme salt water exposed conditions. Your COLORSTEEL® supplier is the best person to recommend if this is the COLORSTEEL® solution you need for your project.

COLORSTEEL® DRIDEX®

Create a warmer, drier and healthier home with DRIDEX®



An innovative solution that delivers superior condensation absorption and enhanced ventilation. Dridex® combines a thin layer of specialised absorbent fleece to the underside of any COLORSTEEL® sheet, negating the need for roofing underlay. It works to absorb accumulating moisture from the roof cavity and then releases it when conditions improve.

Profile

At COLORSTEEL®, we work closely with a network of roofing manufacturers who all have their own specific range of profiles. Your preferred roofing manufacturer will be able to share the design details and any other specific information relating to design and installation of the profile you intend to work with. In general, COLORSTEEL® is available in four forms of profile: Corrugate, Trapezoidal, Trough and Tray.

CORRUGATE

A traditional and classic design that's been used on homes across the country for generations. The timeless symmetrical, wave-like pattern of corrugate looks great on villa reroofs but equally works well as roof or wall cladding on modern architectural designs.

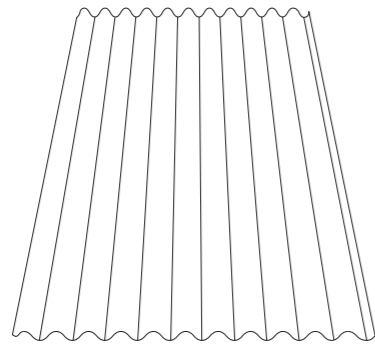

TRAPEZOIDAL

The crisp, clean lines of this profile add a modern touch to any building. Trapezoidal profiles are versatile and have a high strength-to-weight ratio, not only looking great but also being a perfect choice for a wide variety of applications.

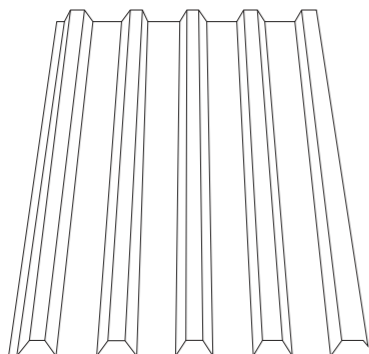

TROUGH

Traditionally used in commercial applications but used widely across both residential and commercial projects in recent times, trough sections generally have 2 to 3 pans giving a bold look. These profiles are secret clip fixed. This minimises roof penetrations and gives better allowance for thermal movement.

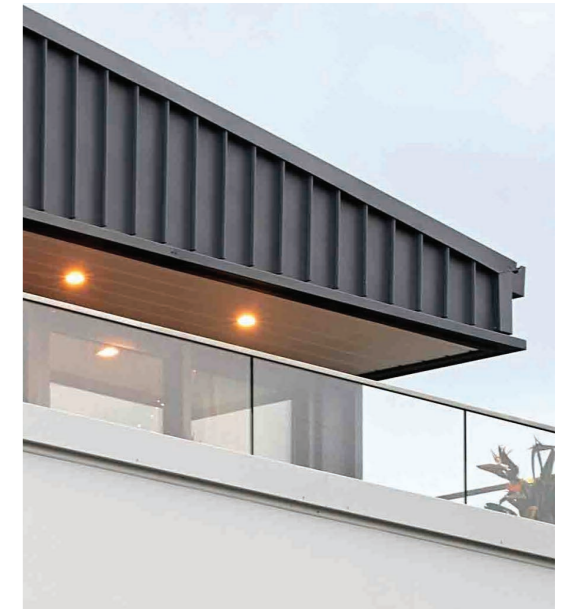
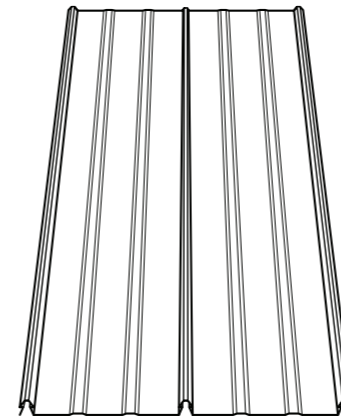

TRAY

Consisting of a single pan to replicate the hand formed roofs popular in Europe centuries ago. The sleek aesthetic of the tray profile has made it a favourite with architects and designers for contemporary homes. It's minimalistic design and secret clip fastenings make it a popular choice for wall cladding as well as roofing.

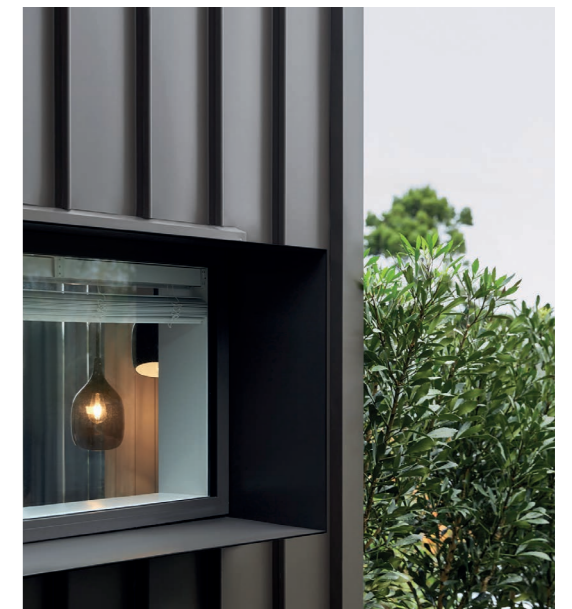
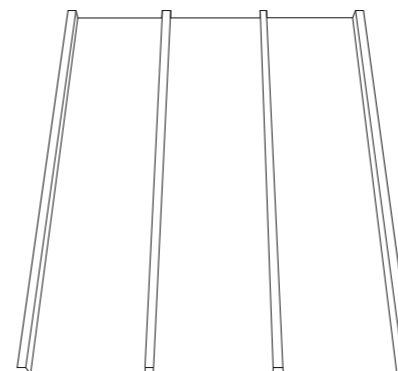

Profile illustrations are representations only. For scale drawings and specific profile measurements, refer to roofing manufacturer's website.

Colours



Our colour range is inspired by our home; the beautiful, diverse and ever-changing landscape of Aotearoa, New Zealand. Scan the QR code to view our Standard colour range.

Non-Standard and Special colours are available upon request. Please check with your COLORSTEEL® supplier or email specifications@colorsteel.co.nz for more information.

Finishes

COLORSTEEL® offers a range of painted finishes, including our most popular, tried and trusted Classic Gloss Finish, with some of our top performers available in a Lower Gloss and for something unique and special you can choose from our Matte range - an innovative and premium paint technology.

Reflectivity & Glare

There are two measures of reflectance, light and solar, that are used for quite different purposes.

Total Solar Reflectance (TSR) measures the percentage of solar energy across the entire spectrum that is reflected away from an object. This correlates closely to the temperature that the object will reach. Colours with a high TSR will generally absorb less thermal energy and will reduce the heat transferred to the roof.

Light Reflectance Value (LRV) measures the percentage of light reflectance only in the visible sector of the spectrum. This contributes to glare. Some councils will have limits on maximum LRV values.

COLORSTEEL® COLOUR	TSR*	LRV*
Cloud	69%	74%
Ebony	5%	5%
Ebony Low Gloss	5%	5%
FlaxPod®	21%	7%
FlaxPod® Low Gloss	22%	7%
FlaxPod® Matte	20%	6%
Grey Friars	26%	10%
Grey Friars Low Gloss	27%	11%
Gull Grey	57%	51%
Ironsand	25%	8%
Ironsand Low Gloss	25%	8%
Karaka	24%	8%
Lichen	42%	28%
Mist Green	39%	25%
New Denim Blue	24%	11%

COLORSTEEL® COLOUR	TSR*	LRV*
Permanent Green	25%	10%
Pioneer Red	35%	12%
SandBar™	48%	34%
SandScape®	66%	66%
Sandstone Grey	41%	27%
Sandstone Grey Low Gloss	42%	27%
Scoria	30%	10%
Slate	25%	9%
StonePeak™ Matte	53%	48%
Thunder Grey	29%	12%
TidalDrift® Matte	29%	13%
Titania	66%	68%
TuiTuft®	66%	68%
Windsor Grey Low Gloss	20%	7%

* The TSR & LRV percentages listed in this colour chart are accurate at the time of printing. Please note these values are subject to a tolerance of ±5%. Factors such as production tolerances, natural weathering and environmental conditions may impact the quoted values. For the most up-to-date values, we recommend referring to our website, where any revisions or updates will be reflected. It is important to verify the current values prior to making any decisions or selections based on these metrics.

Colour match paints (touch up paint)

Colour match paint is designed to pre match accessories and brackets prior to installation. It should not be used to repair scratches as it will weather differentially to the COLORSTEEL® surface.



COLORSTEEL® Ironsand, Corrugate Profile
Wairarapa Haybarn

Compatibility

When two different metals are in contact and moisture is present, one metal will sacrifice itself over the other leading to accelerated corrosion of the sacrificial material. This is known as galvanic or bi-metallic corrosion. A similar problem can also occur with water flowing over dissimilar metals. To prevent accelerated corrosion when using two separate metallic materials, compatibility must be considered from the very start of your project.

Compatibility of materials in contact

CLADDING MATERIAL	WET CONTACT WITH:	
MAXAM™ & ALTIMATE®	Bare Aluminium	✓
	Bare Galvanised	✓
	Bare Zinalume	✓
	Copper / Brass	✗
	Stainless steel	✗
	Plastic / Glass	✓
	Concrete	✗
	Timber	✗
Butyl Rubber	✗	

Compatibility of materials subject to run-off

CLADDING MATERIAL	RUN-OFF FROM:	
MAXAM™ & ALTIMATE®	Bare Aluminium	✓
	Bare Galvanised	✓
	Bare Zinalume	✓
	Copper / Brass	✗
	Stainless steel	✓
	Plastic / Glass	✓
	Concrete	●
	Untreated Timber	✓
	Treated Timber	●
	Butyl Rubber	✓

KEY: ✓ Ok | ✗ Not ok | ● Avoid where possible

Run-off from inert materials

Run-off from inert surfaces such as glazed tiles, aluminium and aluminium-dominant metallic coatings, fibreglass, pre-coated metals, glass or any painted surface can cause corrosion of unpainted galvanised steel and other zinc-dominant metallic coatings. This is known as 'drip-spot corrosion' or 'inert catchment corrosion' and can be avoided during the design consideration stage.

Water sitting on a surface absorbs carbon dioxide and forms carbonic acid, which is reactive with zinc. On a galvanised surface, the carbonic acid reacts with the zinc and becomes neutral. On an inert surface, the carbonic acid is not neutralised, and reaction will be concentrated on any drip points on an unprotected zinc surface.

As the formation of carbonic acid takes time to occur, inert catchment corrosion is normally seen at specific drip points of dew off a roof rather than below rain washed walls and windows.

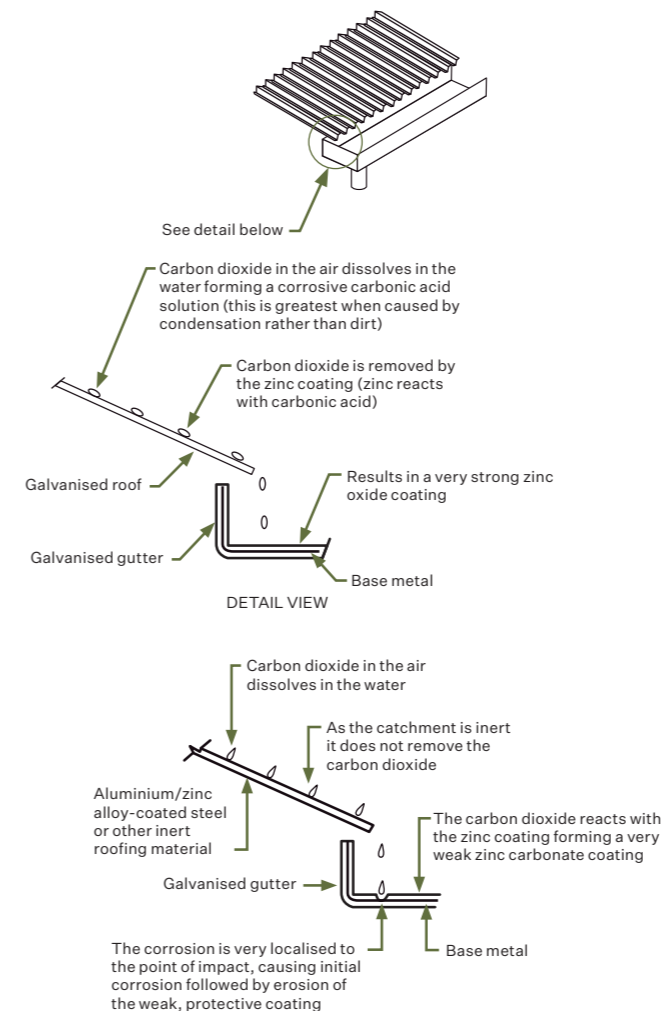

Flues, Fume Extractors & Vents

Corrosive compounds can be released through roof vents and discharged onto the roof surface. The immediate area of the roof adjacent to the vent is then at increased risk of corrosion.

- When designing flues, ensure the height allows for combustion by-products to be dissipated.
- Install filter elements to contain hazardous material.
- Ensure combustion appliances are maintained and run as efficiently as possible to allow complete combustion. Do not burn timber containing copper-based preservative.
- Regularly wash the roof to remove contaminants.

Wet storage damage

Stacked sheets may deteriorate rapidly if water enters the pack. Sheets that are delivered wet or become wet in storage must be used immediately or dried. Drying can be done by cross stacking them on a slope to allow water to drain and air to circulate between the sheets. Long term storage may only be done in a dry, well-ventilated environment. Take care to protect the material from corrosive and damaging substances such as acid, cement, wet grass etc.

Failure to follow these handling and storage precautions could result in spoiling the surface appearance of the products and severely reducing their service life. The result of wet storage damage could be a bubbling of the paint surface. The warranty will not cover any damage that's been caused by wet stack corrosion.



External moisture

Design details to satisfy the requirements of the Building Code can be found in E2/AS1, NZMRM Metal Roof and Wall Cladding Code of Practice or the roofing manufacturers website.

Pitch

The New Zealand Building Code provides a minimum roof pitch required. Below are the minimum pitch figures shown in the NZMRM Metal Roof and Wall Cladding Code of Practice. Refer specific enquiries to the Profile Manufacturer who may have an alternative solution. In addition to the below table, curved roofs must meet the minimum pitch for the profile at the eaves.

Roof Pitch Requirements

Different profiles have different minimum pitch limitations.

PROFILE	RIB HEIGHT	MINIMUM PITCH
Trapezoidal asymmetrical	20 – 35 mm	4°
Trapezoidal asymmetrical and symmetrical	36 – 60 mm	3°
Trapezoidal symmetrical	20 – 35 mm	4°
Concealed Clip / Trough	>30 mm	3°
Concealed Clip / Trough	<30 mm	8°
Standing seam fully supported flat sheet metal	>30 mm	3°
All other types of fully supported flat sheet metal		5°
Corrugated and other profiled sheeting	16.5 – 20 mm	8°
Corrugated and other profiled sheeting	21 – 35 mm	4°
Corrugated and other profiled sheeting	>35 mm	3°

Structure

The strength of a roof profile is dependent on the profile, material grade and material thickness. When the roofing profile is specified, the roofing manufacturer will recommend a fastening pattern to suit the span and associated wind load. Each profile will have a designated fixing type, either penetrating fasteners such as self-drilling screws, or secret clip fastenings. We recommend fasteners with equal or superior durability than the cladding.

Foot traffic

Resistance to damage by foot traffic is not a requirement of the Building Code but roofs with high traffic levels should be designed with foot traffic in mind to avoid damage. Such circumstances include roofs with solar panels and complex monopitch roofs where regular maintenance, or access is required. Generally, 0.55mm is the recommended minimum material thickness for roofs where moderate to high foot traffic is anticipated.

Consider the following when designing:

- Allow and install for catwalks and platforms over the high traffic areas, where regular access may be required for maintenance of equipment such as solar panels or air conditioning units. Aluminium or Galvanised material for catwalks is recommended.
- Avoid creating unwashed areas with platforms and catwalks.
- Safe access and fall restraint systems need to be considered when designing roofs with regular foot traffic.

Fire

COLORSTEEL® products have been tested in accordance with ISO 5660 Parts 1 and 2 by BRANZ. The tests were carried out in accordance with the test procedures described in ISO 5660: (2002), Reaction-to-fire tests – Heat release, smoke production and mass loss – Part 1: Heat release rate, and Part 2: Smoke production rate.

The group number was determined in accordance with Verification Method C/VM2 Appendix A of the NZ Building Code. COLORSTEEL® Maxam™ and Altimate® are Group 1-S products, please refer to individual Product Information Sheets for further fire information.



Expansion allowance & temperature

All roofing and wall cladding is subject to expansion and contraction due to temperature extremes, in particular darker colours and long spans. Fixing systems must allow for expansion and accommodate the longitudinal movement. Excessive expansion on pierced fastened roofs can result in snapping of fasteners and excessive roof noise. Noisy roofs are most often associated with long low-pitched dark roofs. To minimise roof noise, consider lighter colours, avoid long spans and allow for effective ventilation of the roof cavity.

Typical Roof Temperatures (summer average, calm conditions)

	INSULATED CEILING SPACE	UNINSULATED
Light Colours (e.g. Titania)	60°C	50°C
Medium Colours (e.g. Mist Green)	80°C	70°C
Dark Colours (e.g. Karaka)	90°C	75°C

Roofing manufacturers can supply fixing details to allow for thermal expansion of lengths over 12 metres.

Internal moisture

As building inhabitants create water vapour, which is lighter than air, a lot of this can migrate into the ceiling space. This can cause problems with mould and rot as well as affecting the health of the inhabitants. Ventilation is recommended to prevent problems occurring, particularly in buildings with low ceiling cavity volumes. One of the best ways to achieve increased ventilation of a ceiling cavity is to use COLORSTEEL® Dridex®. This removes the need for separate underlay, improving speed of installation and increasing air movement and removal of water vapour from the ceiling space.

Moderating building temperatures

Through its infrared reflectance technology, COLORSTEEL® utilises a range of pigments that reflect a larger proportion of the sun's energy which can lower roof temperatures by up to 8°C depending on colour. The result is a reduced roof temperature and a moderated temperature for the internal environment. Refer to pg 8 for total solar reflectance values

Flashings & Ridge Caps

Flashings and ridge capping should be manufactured wherever possible, from materials that have the same paint system as the roof to ensure equal durability and consistent weathering. Soft edgings and accessories must be colour matched prior to installation. Sealant should be neutral cure or MS type, sandwiched between the surfaces being joined and secured with 4mm sealed rivets at 50mm centres.

Penetrations

Penetrations should be designed according to the MRM Code of Practice recommendations in line with their type, size and positioning. Where penetration flashings are required, neoprene, silicone rubber, EPDM or aluminium offer excellent performance.

Swarf

Hot swarf created from activity such as metal grinding and friction cutting can embed deeply into the COLORSTEEL® surface potentially affecting the durability. This, and other swarf created from acceptable activity such as drilling holes and cutting by shear, may produce surface rust staining but will not compromise the life of the roof. It's the responsibility of the installer or trades person to remove any swarf created during installation.

Photovoltaic Panels

Photovoltaic (PV) panels can be successfully installed on COLORSTEEL® roofs. The following practices will help to ensure the long-term performance, durability and aesthetic appeal of COLORSTEEL® products.

1. Roof clearance

Ensure adequate clearance is available between the PV panels and COLORSTEEL® products. This will:

- Assist with self-cleaning and limit the build-up of leaves and other debris.
- Provide easy access for cleaning, inspection and maintenance of the roofing material and fasteners beneath the PV panels.
- Allow air movement to quickly dry areas beneath the PV panels. This may also benefit the performance of the PV panels, as electrical output is usually temperature dependent. Avoid dissimilar incompatible materials.

2. Water tightness

Ensure continued water tightness of your COLORSTEEL® roof:

- Install PV panels to allow free drainage of moisture from all surfaces to avoid water ponding.
- Any penetrations through the roof should be placed to minimise the risk of water ingress. Ensure penetrations through the roofing sheet are correctly sealed using flashings and sleeves specified for steel roofing.
- Avoid valley fixing or valley holes for electrical cables.
- Install PV fasteners and brackets away from sheet side laps. Fasteners and brackets may distort the profile and interfere with the specifically designed anti-capillary laps, leading to possible water ingress.

3. Positioning

When considering the location and orientation of PV panels, consider the ease of access for maintenance. It is recommended to specify 0.55mm material thickness due to the high foot traffic.

4. Cables and Electrical Earthing

Electrical cables should not sit directly upon the roof as this may lead to an accumulation of dirt, salt and other airborne contaminants. Instead, it is recommended that cables are affixed to the PV panel support structure.

Ensure appropriate earthing of the PV system. Stray currents to COLORSTEEL® products may accelerate corrosion due to electrolysis. Refer to AS/NZS 5033 – Installation of photovoltaic (PV) arrays.

5. Roof Care and Maintenance

PV panels shield COLORSTEEL® products from the drying action of the sun and beneficial washing from rainfall. As such, the roof area directly below the PV panels is considered an 'unwashed area' and must be maintained accordingly.



Helping your roofing & cladding last longer

In New Zealand we can face some harsh environmental conditions. To maximise the life of your COLORSTEEL® products and maintain the warranty, some simple maintenance is required. Choosing the appropriate product for the location and following recommended maintenance practices will help to ensure the long-term performance, durability and aesthetic appeal of the COLORSTEEL®. For warranty and maintenance recommendations refer to the COLORSTEEL® Maintenance Recommendations brochure.

Washing

All roofing and cladding products are subject to the cumulative effects of weather. Regular washing of COLORSTEEL® products increases their durability by limiting attack from airborne salts, pollutants and other build up. For most roofs rain washing is sufficient to remove deposits and enable the roof to meet its design life. However, annual inspection is recommended to ensure there is no build-up of debris, lichen or deterioration of other materials that may cause premature corrosion to the roof, and to conduct any necessary maintenance.

If lichen or fungus is found it is possible for it to be removed. For more information on lichen removal please see the COLORSTEEL® Removal of Lichen brochure. Care should be taken with chemical washes as they have the potential to damage the paint surface.

Unwashed areas

Consideration should be given during the design stage to ensure the underside of COLORSTEEL® is enclosed and therefore not exposed to the environment, where this is not possible regular maintenance is required. Where unwashed areas cannot be avoided, specify regular washing of these areas as part of an ongoing maintenance programme. Design consideration for easy access must be given to areas that require regular maintenance. Refer to COLORSTEEL® Maintenance Recommendations for detailed information.

Wall cladding

Wall cladding requires manual washing to prevent build-up of contaminants that aren't removed by rain washing. As such, all wall cladding should be treated as an unwashed area and be maintained accordingly.

Other high-risk areas

Other areas that do not receive adequate rain washing require more extensive manual washing. These areas include soffits, undersides of gutters, fascias, and sheltered areas of garage doors as well as under any external objects such as air conditioning units, television aerials, flues and solar panels. Areas adjacent to deciduous trees, and other sources of fall out will also require manual washing.

Over painting

Over painting can be successfully done by washing down the roof and recoating in accordance with the paint manufacturers recommendations. As primer is less resistant to UV exposure, it is recommended that recoating be done before significant areas of primer are exposed.

Extra care is required for preparation of recently installed COLORSTEEL® to ensure adhesion. For more information please refer to the COLORSTEEL® Overpainting Guide.

For further information please also refer to manufacturers recommendation for proprietary building products such as composite systems. Where a product is to be used in aggressive internal or heavy industrial environments, please contact New Zealand Steel Limited for advice.



New Zealand has a wide range of environmental conditions.

MILD

Distance from coast:
East 5km + | West 5km +

MODERATE

Distance from coast:
East 500m-5km | West 1-5km

SEVERE

Distance from coast:
East 100-500m | West 500m-1km

VERY SEVERE

Distance from coast:
East 25-100m | West 50-500m

EXTREMELY SEVERE

Distance from coast:
East 0-25m | West 0-50m

This chart is intended as a guide only. Design, position and other factors can influence which product is recommended. Please contact COLORSTEEL® or your supplier for further advice on the best COLORSTEEL® product to use. Warranty queries can be sent to warranty@colorsteel.co.nz.

■ Eligible for a warranty.

■ Not eligible for a warranty.

¹ Against perforation as a result of corrosion.

² Covering the paint surface against flaking, peeling and excessive fade.

Typically starts 5 kilometres (depending on your location) from breaking surf such as is found on exposed coasts or greater than 1 kilometre from calm saltwater such as estuaries. Mild environments categorise the majority of New Zealand and are characterised by:

- No salt deposits.
- No smell of salt in the air.

Typically starts 500 – 1000 metres (depending on your location) from breaking surf such as is found on exposed coasts or in the immediate vicinity of calm saltwater such as estuaries. Moderate environments are characterised by:

- Little or no salt deposits.
- The occasional smell of salt in the air.

Typically starts 100 – 500 metres (depending on your location) from breaking surf such as is found on exposed coasts, characterised by:

- Light salt deposits.
- A frequent smell of salt in the air.
- In the immediate vicinity of large expanses of calm salt water such as harbour foreshores.

This environment may be extended inland by prevailing winds & local conditions.

Typically starts 25 metres from the high-water mark on the east coast and 50 metres from the high-water mark on the west coast, characterised by:

- Heavy salt deposits.
- The almost constant smell of salt spray in the air.
- Close to breaking surf such as is found on exposed coasts.

For anything within 100 metres of a salt water body, please contact COLORSTEEL® for confirmation of your warranty. This environment may be extended inland by prevailing winds & local conditions.

The environment typically starts 0 metres from the high-water line on both coasts with the following conditions:

- Very heavy salt deposits.
- Constant smell of salt spray in the air.
- Immediate vicinity of breaking surf and offshore construction such as on jetties, wharfs or breakwaters.

For anything within 100 metres of a salt water body, please contact COLORSTEEL® for confirmation of your warranty. This environment may be extended inland by prevailing winds & local conditions.

			ROOFING	WALL CLADDING	ACCESSORIES	ROOFING	WALL CLADDING	ACCESSORIES	ROOFING	WALL CLADDING	ACCESSORIES	ROOFING	WALL CLADDING	ACCESSORIES	ROOFING	WALL CLADDING	ACCESSORIES
MAXAM™ Superior protection for Mild inland environments to Very Severe coastal environments.	WARRANTY	PERFORATION ¹	50 YEARS	30 YEARS	15 YEARS	40 YEARS	25 YEARS	15 YEARS	30 YEARS	20 YEARS	15 YEARS	20 YEARS	20 YEARS	15 YEARS	Not recommended in this environment		
		PAINT ²	18 YEARS	15 YEARS	10 YEARS	18 YEARS	15 YEARS	10 YEARS	15 YEARS	15 YEARS	10 YEARS	15 YEARS	15 YEARS	10 YEARS			
	MAINTENANCE	Rain washing	Manual washing every year	Manual washing every 6 months	Rain washing	Manual washing every year	Manual washing every 6 months	Rain washing	Manual washing every 6 months	Manual washing every 3 months	Rain washing	Manual washing every 3 months	Manual washing every month				
ALTIMATE® Ultimate protection for Extremely Severe marine and breaking surf environments	WARRANTY	PERFORATION ¹	50 YEARS	30 YEARS	15 YEARS	40 YEARS	25 YEARS	15 YEARS	30 YEARS	25 YEARS	15 YEARS	30 YEARS	25 YEARS	15 YEARS	25 YEARS	20 YEARS	15 YEARS
		PAINT ²	18 YEARS	15 YEARS	10 YEARS	18 YEARS	15 YEARS	10 YEARS	15 YEARS	15 YEARS	10 YEARS	15 YEARS	15 YEARS	10 YEARS	15 YEARS	15 YEARS	10 YEARS
	MAINTENANCE	Rain washing	Manual washing every year	Manual washing every 6 months	Rain washing	Manual washing every year	Manual washing every 6 months	Rain washing	Manual washing every 6 months	Manual washing every 3 months	Rain washing	Manual washing every 3 months	Manual washing every month				

The MAXAM™ warranties for roofing and cladding in the above table also apply to DRIDEX®. DRIDEX® is not recommended for accessories. Accessories: Gutters, downpipes and fascia.

Made to stand the test of time

Warranty

As New Zealanders we are used to extreme environments. In these areas, salt spray can produce highly corrosive conditions that may have a detrimental effect on the ongoing appearance and resilience of a building. Now, with the ever-increasing use of pre-painted profiled steel in both roofing and cladding, it has never been easier to select the appropriate material for your project, with COLORSTEEL® Maxam™ suitable for most New Zealand environments.

For detailed information on warranty and maintenance refer to the COLORSTEEL® Maintenance Recommendations brochure.





NOTE: Buyers and users of New Zealand Steel Limited products and services must make their own assessment of the products for their own conditions. All queries regarding product specification, purpose or application should be directed to New Zealand Steel Limited, email specifications@colorsteel.co.nz. New Zealand Steel Limited reserves the right to modify products, techniques, equipment and statements to reflect improvements in the manufacture and application of its products. The information contained in this brochure is accurate as at July 2024 and supplied without prejudice to New Zealand Steel Limited's standard terms and conditions of sale. In the event of conflict between this information and the standard terms and conditions, the standard terms and conditions prevail. COLORSTEEL®, MAXAM™, Activate™, Altimate®, Dridex®, FlaxPod®, TidalDrift®, TuiTuft®, SandBar™, SandScape® and StonePeak™ are registered trademarks of New Zealand Steel Limited. Copyright© New Zealand Steel Limited, July 2024. 114842

COLORSTEEL.CO.NZ

