

POESIA GLASS TECHNICAL MANUAL

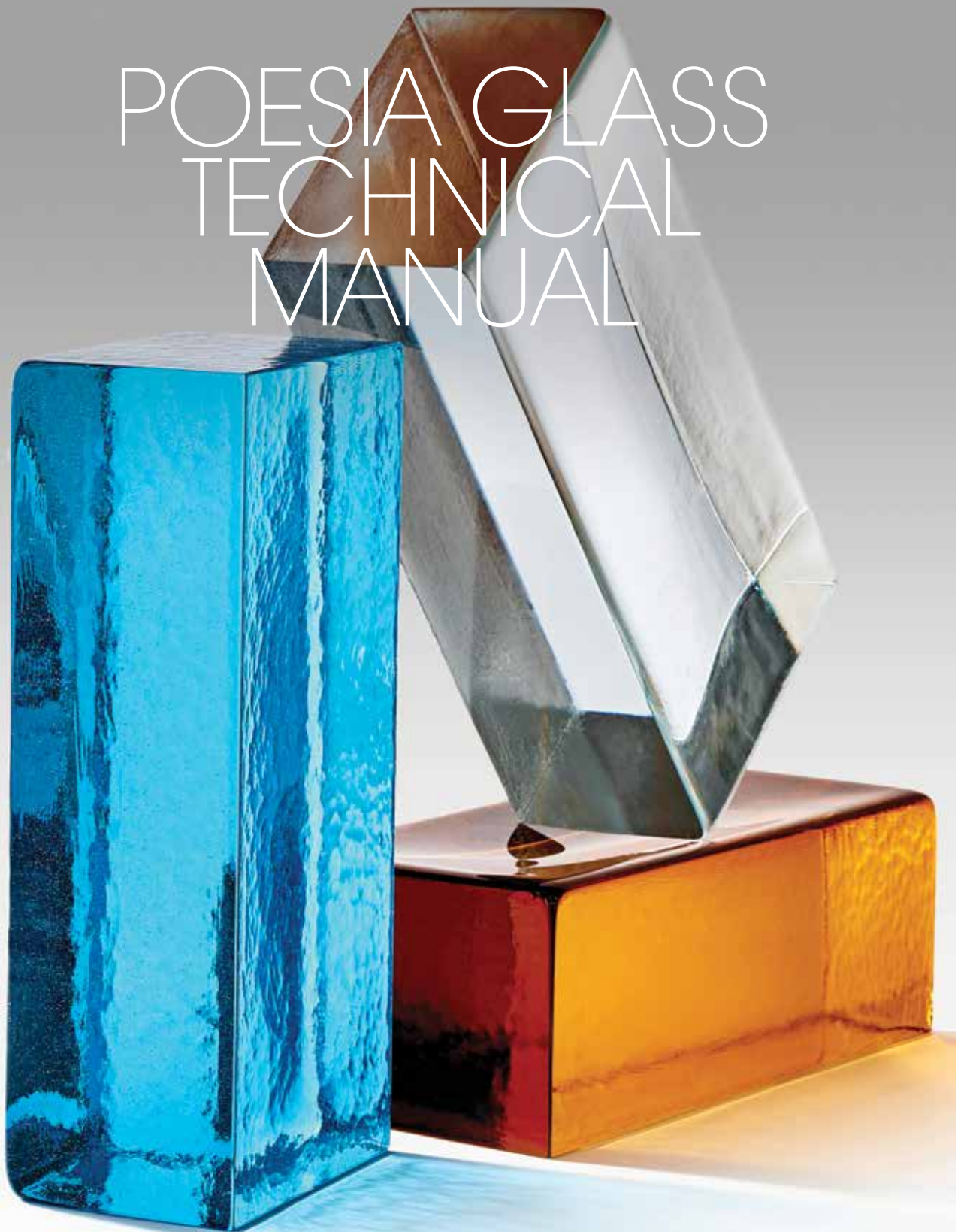

CONTENTS

03	<i>1.0 Preliminary Comment</i> <ul style="list-style-type: none"><i>1.1 Applications</i><i>1.2 Design Fundamentals</i><i>1.3 Responsibilities</i><i>1.4 Colour Variation</i><i>1.5 Technical Details</i>
04	<i>2.0 Product Specifications</i> <ul style="list-style-type: none"><i>2.1 The Range</i><i>2.2 Technical Specifications</i>
06	<i>3.0 Installation and Handling Instructions</i> <ul style="list-style-type: none"><i>3.1 Storage</i><i>3.2 Handling</i><i>3.3 Materials Required for Installation</i><i>3.4 Preparation of Product</i><i>3.5 Laying of Product</i><i>3.6 Cleaning</i><i>3.7 Maintenance</i>
07	<i>4.0 Engineering Details</i> <ul style="list-style-type: none"><i>4.1 Maximum wall dimensions for Poesia Glass bricks</i><i>4.2 Restraint Details</i>
11	<i>We are Brickworks</i>

1.0

preliminary comment

The purpose of this document is to provide a guideline for the building industry, including architects, builders, bricklayers and building officials on the correct use and installation of the Poesia Glass bricks.

This Technical Manual is part of the manufacturer's instructions and as such, should be made familiar to all involved.

1.1 Applications

The brilliant translucence of Poesia Glass Bricks characterises their primary usage and prominence as feature walls found in areas requiring an enhancement of interior space or an increase in natural light. As such, these walls are generally free-standing and non-loadbearing and are typically not tied to a structural frame in the fashion of standard clay bricks.

1.2 Design Fundamentals

Masonry units made of glass are not included within the scope of AS3700 Masonry structures. However, it is considered appropriate to use AS3700 for design of masonry walls incorporating Poesia Glass bricks as:

1. The glass units and mortar thickness are of similar dimensions to conventional masonry; and
2. The masonry flexural tensile strength has been tested.

The design charts included in this manual are limited to internal non-load bearing applications and any other applications must be engineered to meet the requirements.

1.3 Responsibilities

Like any product or cladding system, it is essential to have a clear understanding of the product and its installation; this applies to all involved in the process from the designer, the builder, to the bricklayer.

1.4 Colour Variation

Poesia is a glass brick that is individually handmade and will vary in colour and texture. It is important to remember that samples, brochures and other marketing avenues, provide an indicative example of the selected product and its colour. Austral Bricks makes every endeavour to maintain a constant standard, however, if you are not satisfied with the colour of the product upon delivery, you must advise Austral Bricks prior to the laying of the product. Once the product has been laid, it is deemed to have been accepted.

1.5 Technical Details

The technical details and information in this document correspond to the best of our knowledge, with all legislative requirements and good trade practice. They are provided as a guide only and all detailing should be site specific and completed by a competent architectural designer.



2.0

product specifications

2.1 The Range

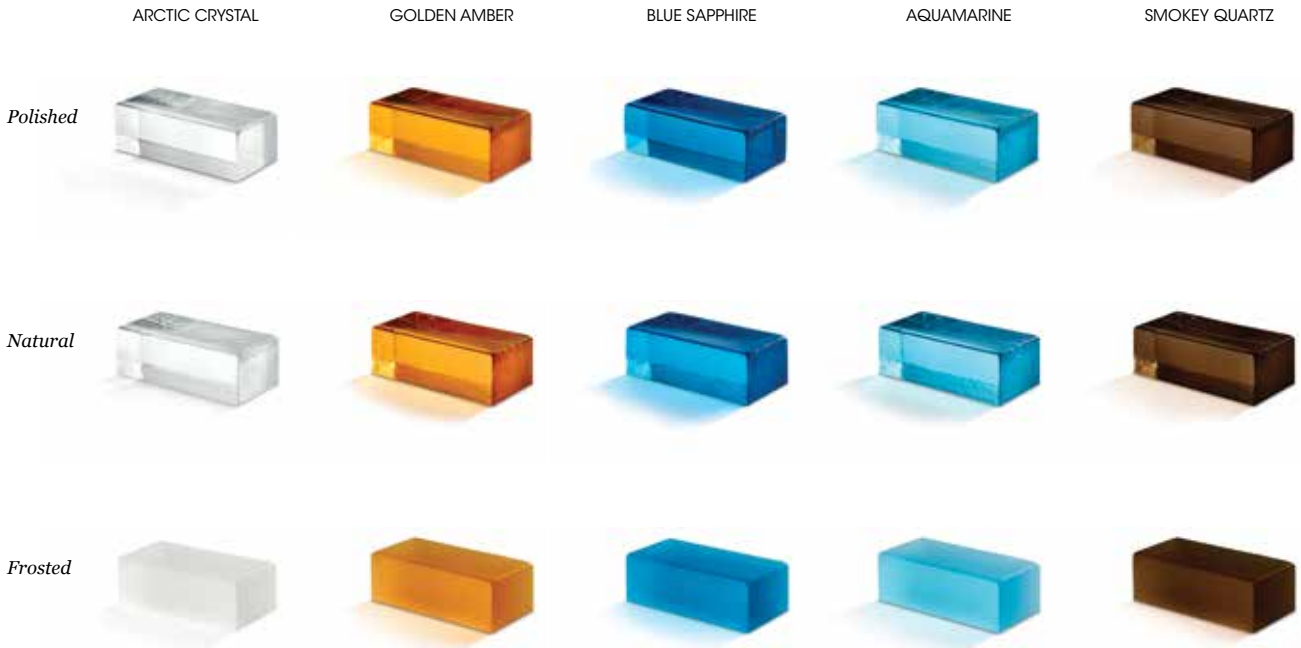

Dimensions

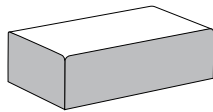

STANDARD BRICK
230 L x 110 W x 76 H mm

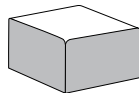

HALF BRICK
110 L x 110 W x 76 H mm

All colours and finishes are available in both standard and half brick sizes.

2.2 Technical Specifications

Standard Brick

CRITERIA	RESULT
Dimensions - Work size (mm): Length	230
Width	110
Height	76
Dimensional Category	DW1
Average Weight / Unit (kg)	4.7
Units/m ²	48.5
Pack size	216
f _{uc} (MPa)	>30
Max Cold Water Absorption (%)	0.0
Initial Rate of Absorption (kg/m ² min)	0.0
e'Factor (mm/m)	0.0
Core Volume (%)	Solid
Durability Class: 40 cycle	EXP
Liability to Effloresce	Nil
Lime Pitting Liability	Nil
Solar Absorbance Rating	NA

Note: This product does not have a fire rating. If a fire rating is required, please contact Austral Bricks. Thermal properties (U-value and SHGC) are also available from Austral Bricks.

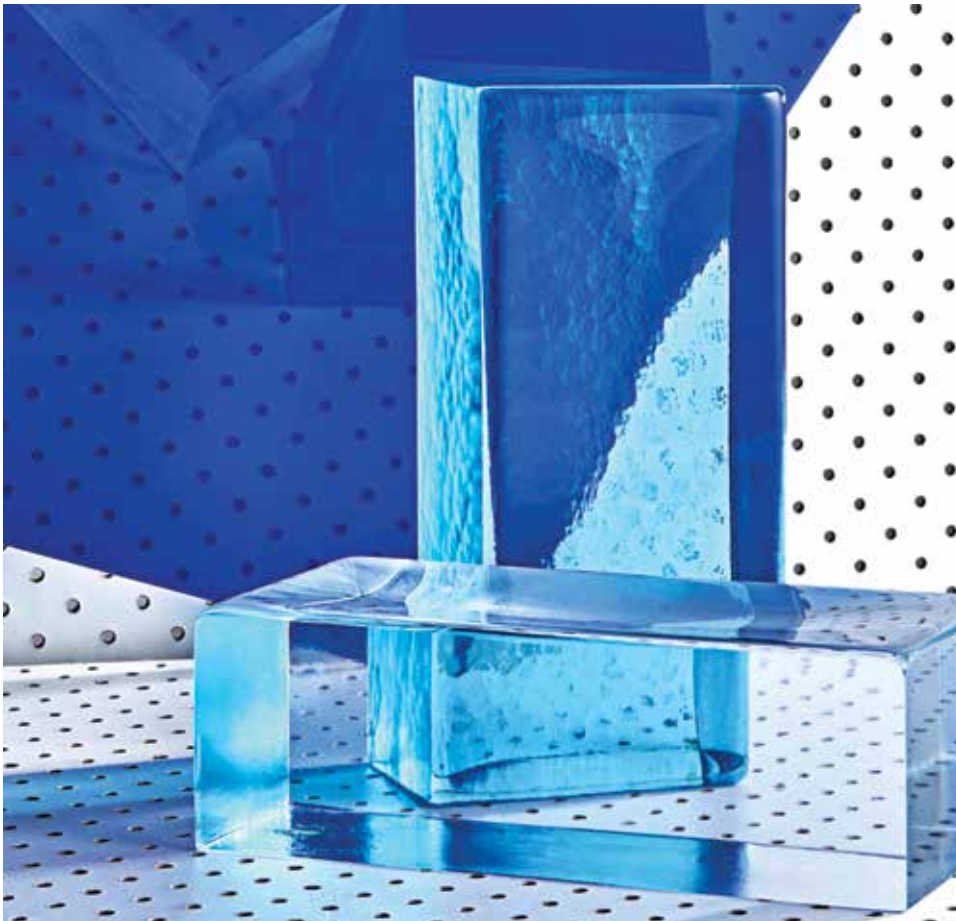

3.0

installation and handling instructions

3.1 Storage

- Keep crates in dry storage.
- Do not stack pallets.
- Once crate straps are broken, minimise movement of crate.
- Avoid crates being exposed to the weather for long periods.
- Keep the top of the crates covered with plastic.

3.2 Handling

- Keep bricks apart to avoid damage when moving.
- Always stack bricks on their edge not the face.
- **Use gloves and avoid using all metal carrying devices to move bricks.**
- Ensure the surface of where the bricks are being moved to is clean and dry.

3.3 Materials Required for installation

- Mortex™ (Factory manufactured, quality assured premixed M4 rated mortar).
- Trowel, level and plumb bob.
- Mechanical mixer.
- Bucket of clean water and cloth for cleaning.
- Weldcrete® to mix with Mortex™.

3.4 Preparation of Product

- Bricks should be dry and clean with no debris of any description on any of the brick.
- If bricks are dirty, wash clean using water and leave to completely dry before using.
- Examine bricks to ensure there are no cracks or that they are damaged in any way.

3.5 Laying of Product

Glass bricks have no water absorption therefore a bonding agent is required to be added to the mortar to ensure adequate bond strength of the brickwork.

- Mortar joints should be 10mm +/- 2mm.
- Weldcrete® bonding agent must be added to the Mortex™ to achieve adequate bond strength.
- The Weldcrete® should be added at a rate of 1 part additive to 4 parts water or as specified by the manufacturer.
- Brush neat Weldcrete® on to the cleaned top and bottom surfaces of the brick. Place the mortar on the brick within 3 minutes before it dries out completely.

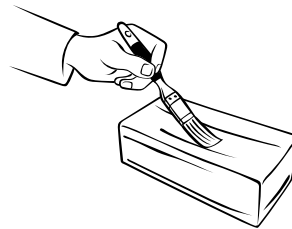

- Bricks should be laid in stretcher bond pattern. Engineering advice needs to be obtained for stack bonded patterns.
- Bricklaying should proceed in the same manner as standard masonry work.
- During installation, use clean water and brush to promptly remove any fresh mortar that splashes onto the brickwork.
- Install 'Control Joints' as required.

3.6 Cleaning

- During installation, use clean water promptly and remove any fresh mortar splashes using a cloth.
- Mortar should not be allowed to dry on the face of the bricks.
- No acid should be used to clean the brickwork.

3.7 Maintenance

One of the great advantages in building in Poesia Glass is that it is virtually maintenance free, however, an annual check should be made and a cloth used to clean the surfaces. A standard glass cleaner can be used if required.

Figure 1: Weldcrete must be added to Mortex to achieve adequate bond strength

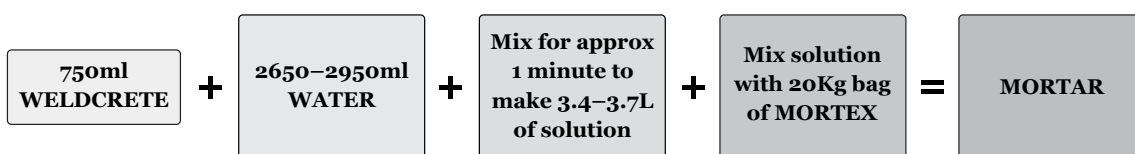

NB: The amount of water can be adjusted within this range to achieve the consistency required.

Section 3.3: Weldcrete® is available from the local branch of Cementaid. For details, please refer to www.cementaid.com
Mortex™ is available from Austral Bricks.

4.0

engineering details

4.1 Maximum wall dimensions for Poesia Glass bricks

The wall charts below are suitable for internal non-load bearing applications only, with respect to structural adequacy.

Chart 1: Walls laterally supported at both ends and top resisting 0.5 kPa out-of-plane load (robustness)

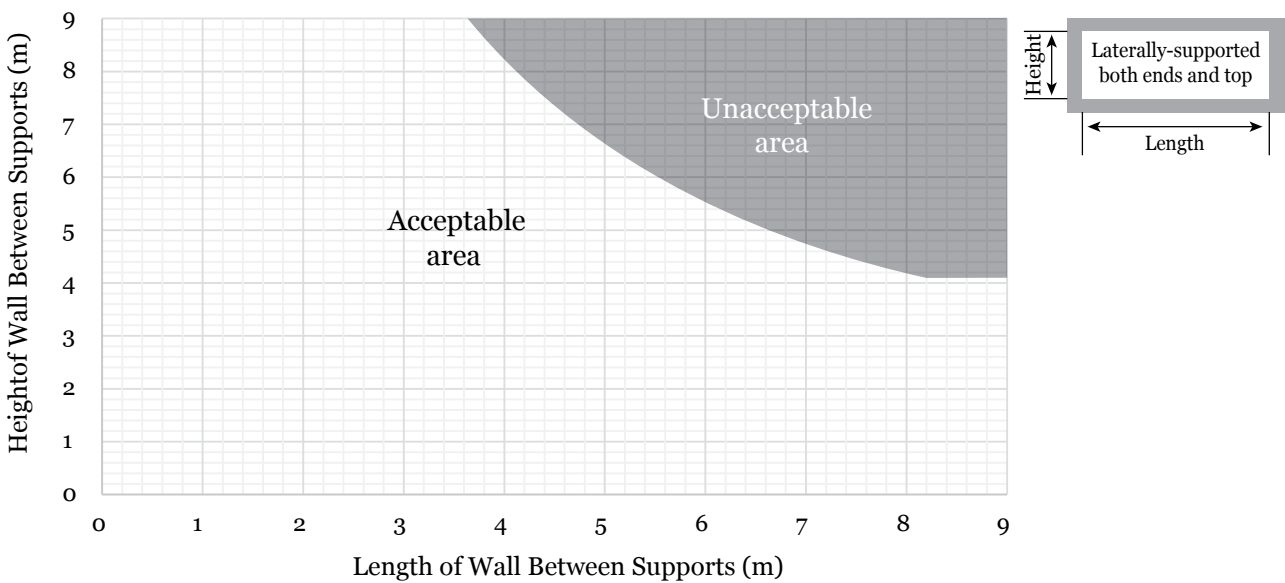

Chart 2: Walls laterally supported at both ends (top released) resisting 0.5 kPa out-of-plane load (robustness)

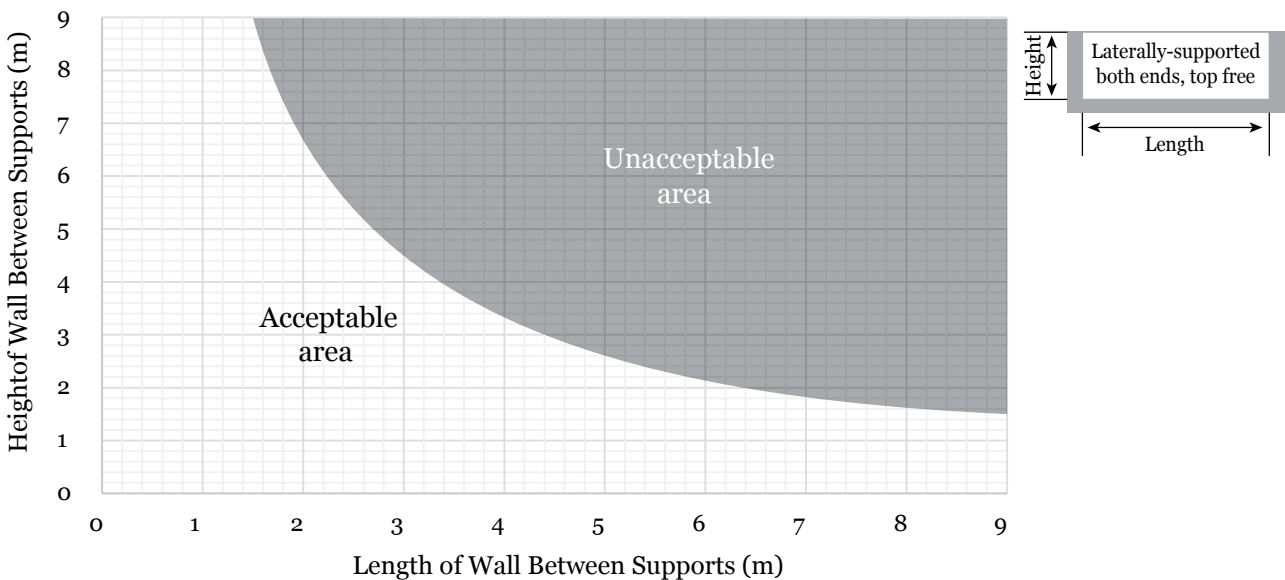

Chart 3: Walls laterally supported at one end and top resisting 0.5 kPa out-of-plane load (robustness)

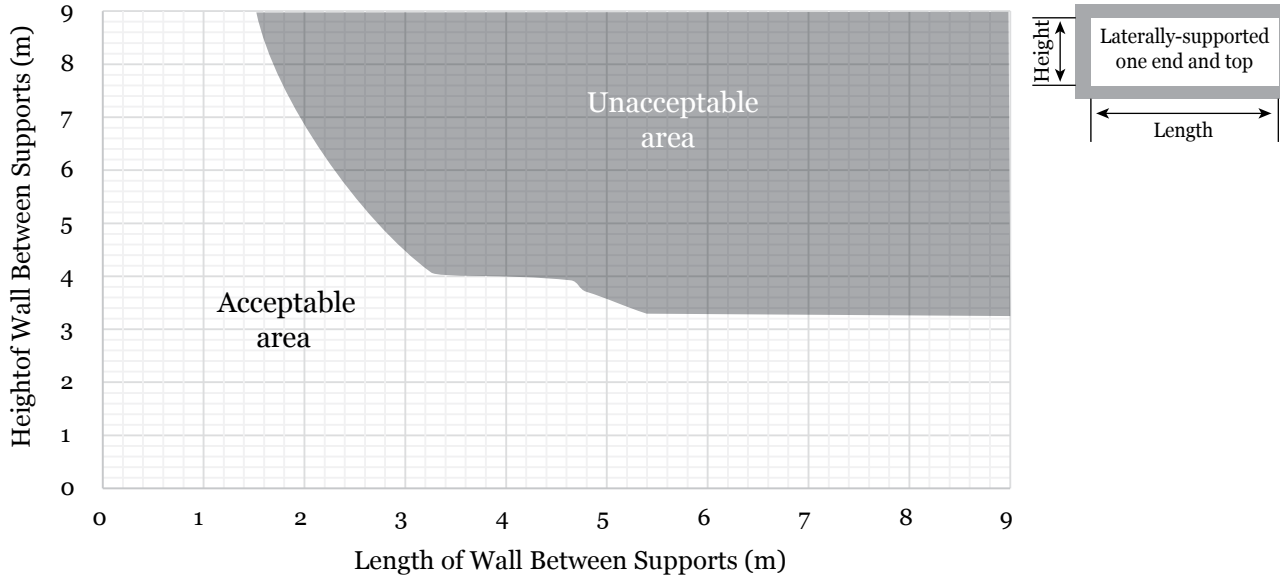
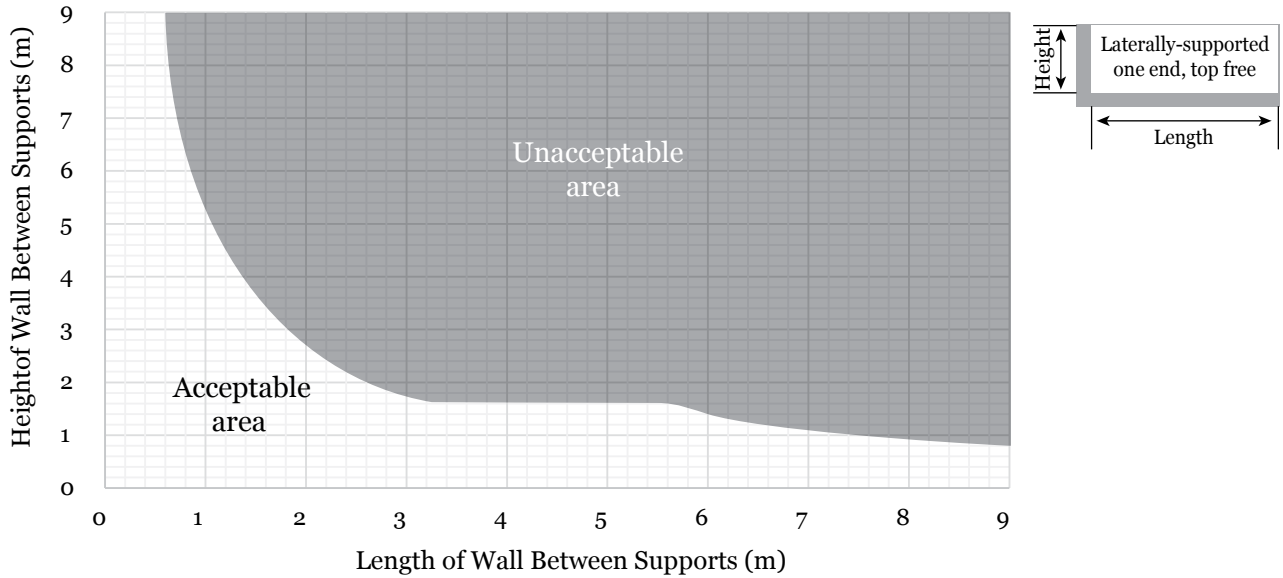

Chart 4: Walls laterally supported at one end (one end and top released) resisting 0.5 kPa out-of-plane load (robustness)



4.2 Restraint Details

An example of horizontal lateral head and bottom restraint is shown in Fig.1 and Fig.2 respectively. An example of vertical lateral restraint is shown in Fig.3.

Figure 1: Lateral head restraint detail

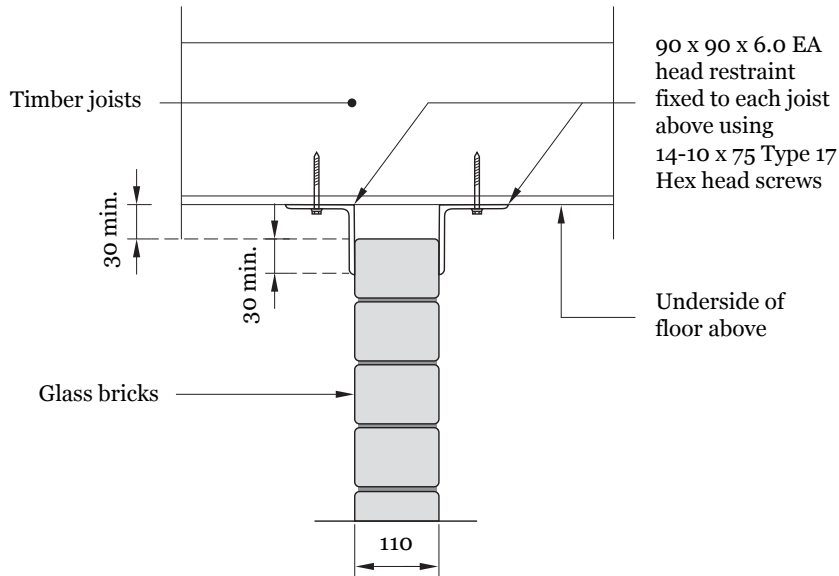
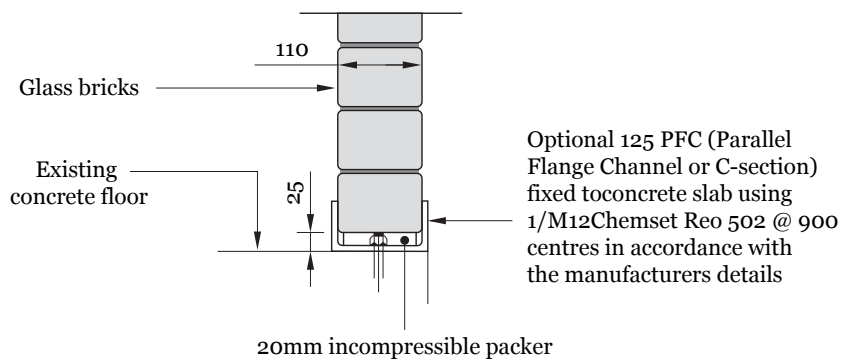
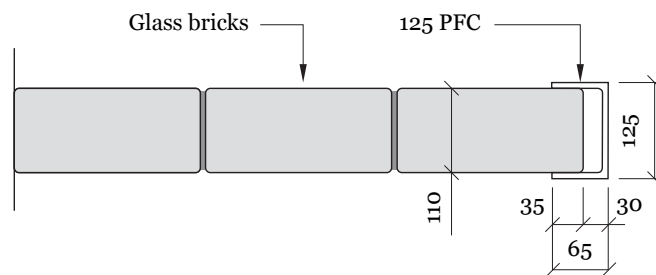

Figure 2: Lateral base restraint



Alternatively, the first course of masonry may be bonded to the floor using the mortar specified in this manual.

Figure 3: End detail





WE ARE

Brickworks

Brickworks Building Products is one of Australia's largest and most diverse building material manufacturers. Under the Brickworks Building Products umbrella are some of Australia's best known building materials brands. Our products include bricks, pavers, masonry blocks, retaining wall systems, precast concrete panels, concrete and terracotta roof tiles, timber products, terracotta façades and specialised building systems.

With a broad product portfolio and manufacturing and sales facilities across Australia, Brickworks Building Products is uniquely placed to service the demands of the building industry.

With over 1,200 staff across Australia and New Zealand, we pride ourselves on our commitment to product, service excellence and our leadership position.

BRICKWORKS — BUILDING PRODUCTS —

 australbricks®

 australmasonry®

 australprecast®

 auswesttimbers®

 bristiler roofing®

 southern cross
cement®

 BOWRAL BRICKS

 nubrik®
authentic brickwork



 terracade™
TERRACOTTA FAÇADE SYSTEMS

Pronto Panel™

INEX>BOARDS™

 GB Masonry

 URBANSTONE®



australbricks.com.au | 13-brick

follow brickworks building products on



DESIGN STUDIOS

Sydney CBD

2 Barrack Street
Sydney
NSW 2000

Melbourne

490 Swan Street
Richmond
VIC 3121

Adelaide

Ground Floor
70 Hindmarsh Square
Adelaide
SA 5000

Brisbane

27 James Street
Fortitude Valley
QLD 4006

Perth

67 King Street
Perth
WA 6000

Hobart

9 Franklin Wharf
Hobart
TAS 7000

A brand of

BRICKWORKS
— BUILDING PRODUCTS —

Proud Supporters



The product images in our brochures give a general indication of colour for your preliminary selection.
We also recommend you view current product samples before making your final decision.

Partners in Design 04/2018