

Product: Multicube	Product Code: M-Cube
Installation Guide Updated March 2015	

RESCO

*Multi***Cube**[®]

Suspended cubicle systems

Step-by-step Installation Guide

March 2015

IMPORTANT

SAFE PANEL HANDLING INSTRUCTIONS



Although Compact Laminate panels are tough and durable, they must be treated with care. Panels can be damaged if not stored or handled properly during assembly.

Store inside and keep in original packaging until needed.

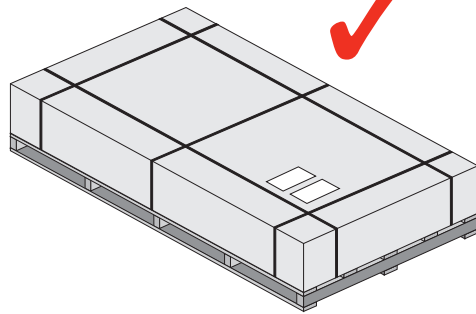

Use caution, machined edges may be razor sharp!

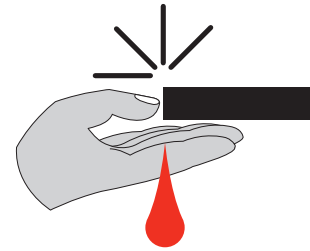

DO NOT store in sun or rain, or at high temperatures.

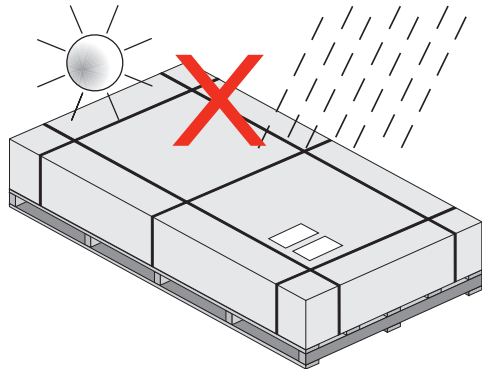

DO NOT slide panels - LIFT them!

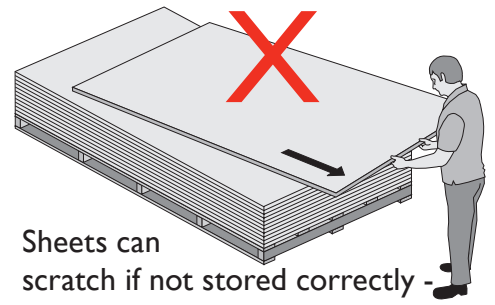

Sheets can scratch if not stored correctly - ensure free of dust and debris.

2 MAN LIFT.

Use suction lifting aids if available.

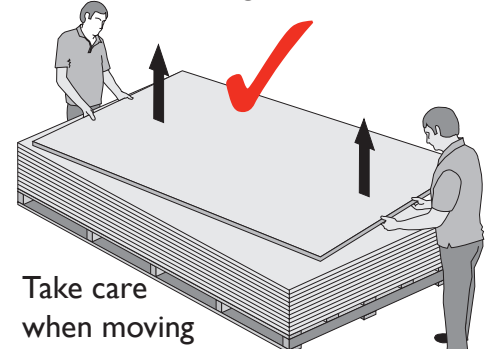

Take care when moving panels they can be damaged if not handled correctly.

DO NOT walk-over.

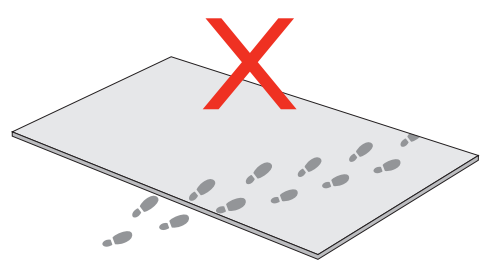

IMPORTANT

CLEANING & MAINTENANCE OF COMPACT LAMINATE

Compact laminate is engineered to last for many years. We provide a 10 year guarantee on panel integrity.

The non-porous surface is easy to clean. The decorative surface and resin core of Compact Laminate is impervious and resistant to most commonly used cleaning agents and disinfectants.



Recommended cleaning agents

Surfaces can be easily cleaned with a dry or damp cloth and if necessary a mild household cleaner.

- **General cleaning:** All-purpose cleaner (e.g. Ajax Spray & Wipe), household cleaners, water or soap are recommended.

It is resistant to everyday wear and tear but needs some attention for harsh conditions and staining.

- **Spray paint:** Turpentine or SPC 801
- **Permanent marker:** Methylated spirits or SPC 801

Never use any of the following on Compact Laminate:

- Do not use abrasive or polishing materials. Abrasive cleaners such as Jif Cream Cleanser, Ajax (powder or liquid), Chemco, Brasso, Mr. Muscle oven cleaner or Scrub free.
- Scourer pads, Wire wool or Sandpaper.
- High pressure water cleaning or steam cleaning of panels is not recommended.
- Neat Janola or other equivalent brands of bleaches.
- Any product containing strong mineral acid such as sulphuric acid, Battery acid, hydrochloric acid, nitric acid or phosphoric acid. Commercial toilet cleaners, grout removers, descalants, rust removers, etc.
- Care must be taken where cleaning agents or solvents are highly acidic or alkaline as these may permanently damage the surface.

Other Tips:

- The use of CRC or equivalent on hinges and indicator bolts is recommended at least once every 3 months (sooner for challenging environments).
- An occasional re-finish of the exposed edges with an “off the shelf” wood-polish will rejuvenate the original polished seen edges.
- Any chemicals should be washed off so that they don’t keep working on the panels.

See our Web site:

www.resco.co.nz/product/multicom - Cleaning instructions

For removal of graffiti – Please call our customer service team **0800 800 950**

Step-by-step Installation Guide

Follow the installation instructions and reference numbered steps on the illustrations.

IMPORTANT NOTES

- When screwing into compact you must pre-drill
- Use low setting on your drills when screw fixing into Compact Laminate. Compact Laminate can break screws or damage the head if your drill is too powerful.
- Don't use hammer drills when installing into Compact Laminate.
- Compact Laminate and Aluminium can damage if not stored or treated properly – take care when you are moving sheets. Larger sheets require 2-man lift.
- The system will be packed so division panels are at the top and the doors are at the bottom.
- Use Diamond tip drill bits for drilling into tiles.

Sit in place and ensure that all the doors are perfect before final rivet. Therefore you can adjust. Ensure plumb both ways.

Tools needed

Level
String line
Chalk line
Stool or small step ladder
Timber blocks (4" x 2")
Timber wedges
Rivet tool
3.5 mm drill bit
5 mm Masonry bit
No. 1 Square drive
No. 2 Pozi-drive
Drop saw
Nylon hammer
Circular saw

Step 1

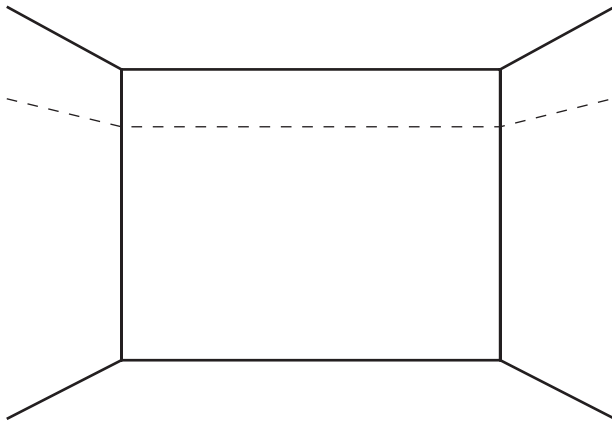

From the plans, mark Datum on relevant walls. Ensure that the lowest point in the floor is used for Datum otherwise the system could be on an angle, or the Headrail height could be too low. Note: on our proprietary system the Datum is normally 1955mm.

Step 2



From the plans, mark the location of the front of the cubicles.

Step 3

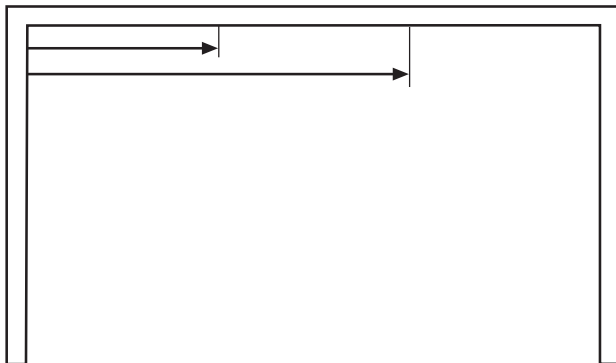

From the plans, mark the division centres on the back wall. Check location of toilets and ensure centred (these are sometimes fitted different to the plans).

Step 4

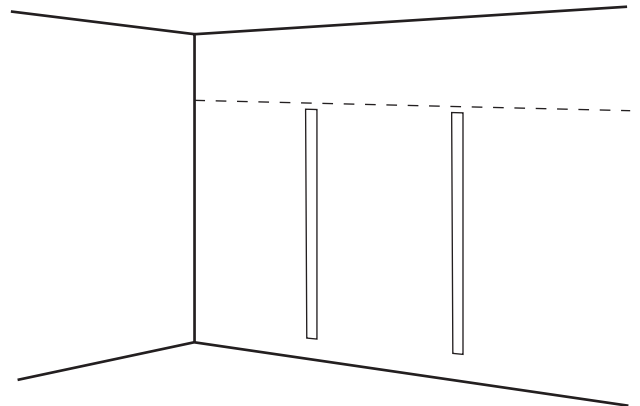

Fix back U-Channels (1748mm) centred on your marks, 47mm below the Datum line.

The U-Channels are predrilled. Ensure screws go into wall frame.

Use 8GA x 32 screws.

Step 5

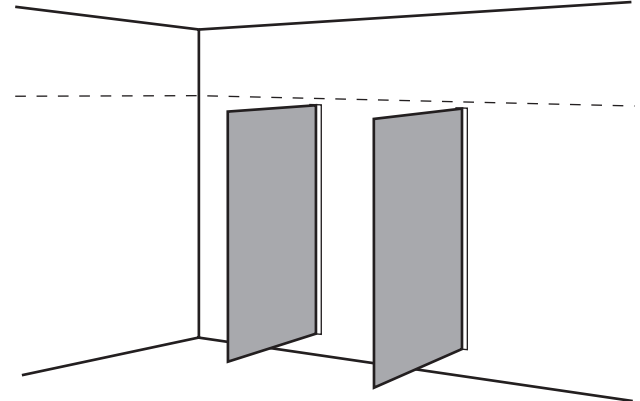

Place division panels into rear U-Channels with 4"x2" blocks underneath to make them level (wedges will be required).

Ensure flush with the top of the U-Channel.

Step 6

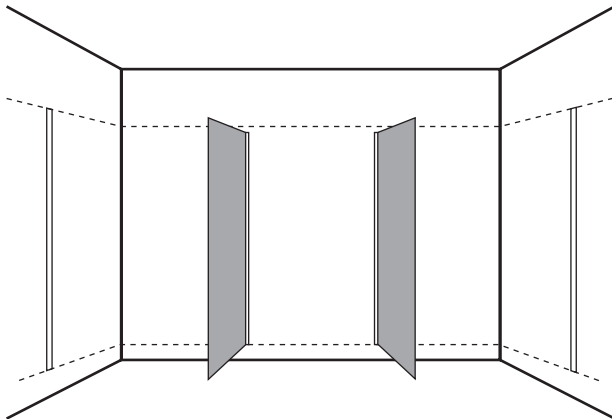

Fix side U-Channels (1795mm) flush with Datum and centred on marks. The U-Channels are predrilled. Ensure screws go into wall frame.

Use (A) 8GA x 32 screws.

Step 7

Adjust division panels so that they align and are square with each other and the other walls.

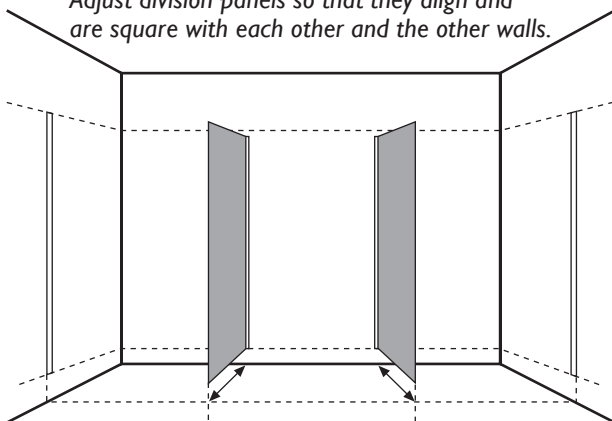

Chalk line on the floor, the front face.

- Chalk line from the centre of the side wall U-Channels.
- Adjust division panels so they are 10mm from the chalk line and aligned with the top of the U-Channel, then fix.

Rivet once, 50mm down from the top of the U-Channel, through one side of the division panel.

Use 3.5mm drill bit with (D) Stainless Steel Pop Rivets.

Note: Sometimes the back wall is not straight. This can be OK as you can either trim the division panels as required, or adjust the front face. Ensure to remark the chalk line and that it's straight, fits and looks good.

Step 8

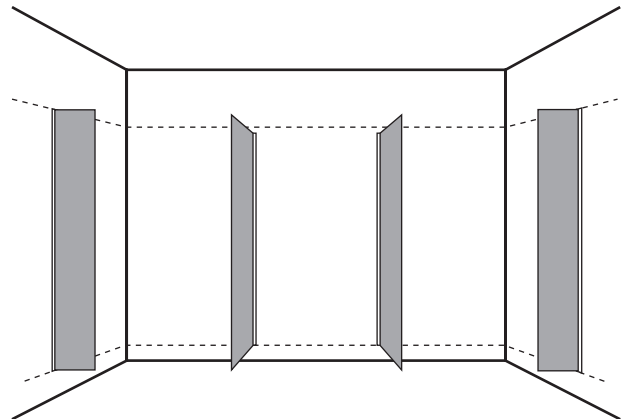

Place hinged Fascia into side U-Channels and align at the bottom. Ensure Plumb, and then fix on the inside of the cubicle with 4 Rivets, 30mm and 600mm down from the top, and the same up from the bottom.

Use 3.5mm drill bit with (D) Stainless Steel Pop Rivets.

Sit the other end Fascia in place. (Do not fix rivet yet).

Step 9

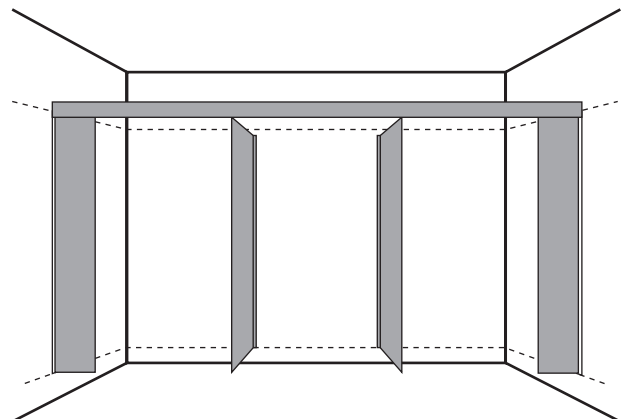

Trim the Headrail to ensure flush with the walls and position on to the top of the Side Fascias.

Ensure that it is 100% into the Headrail pocket. This may require straps to pull it down into place. You must ensure it is fitted correctly (see step 12).

Step 10

Click the 'In-fill' into position so that it is flush with the underneath of the Headrail.

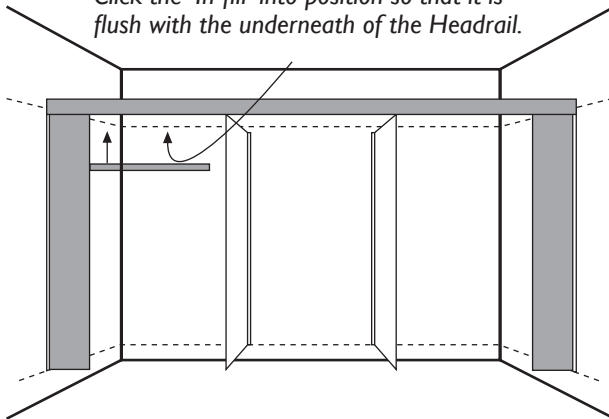

Starting at the hinge Fascia, insert first Door Infill into Headrail.

Clip into place.

This will determine where the next Fascia fits.

Step 11

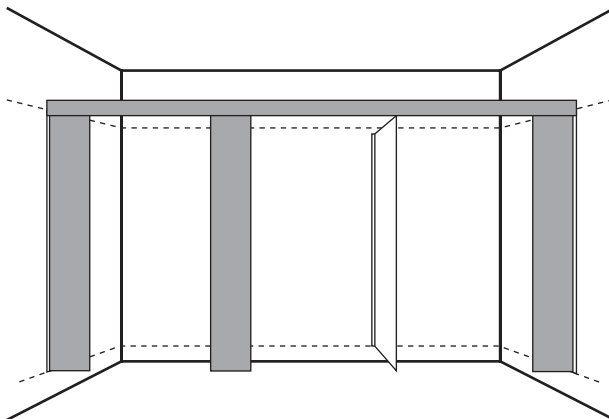

Put second Fascia into Headrail.

- Ensure it is hard into Headrail, hard against the Infill & on to the end of the first division panel.
- Ensure Division panel is slotted into U-Channel.
- Apply a bead of silicone in top of the Fascia before sliding into the Headrail.

Step 12

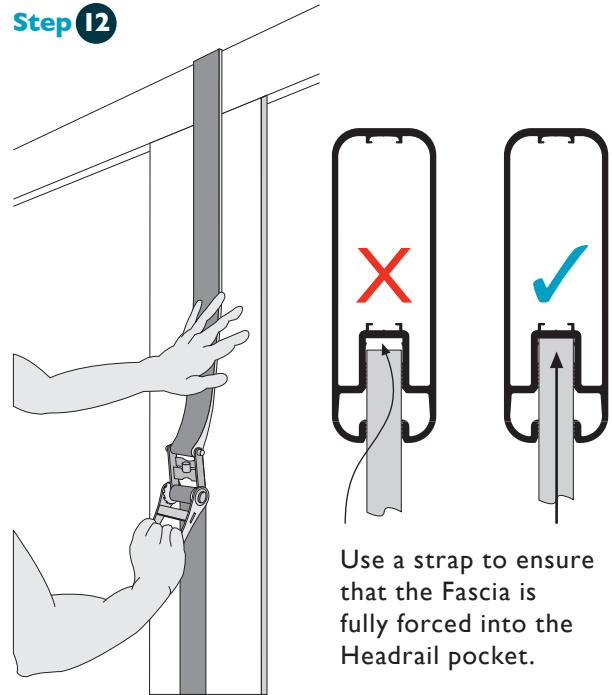

Use a strap to ensure that the Fascia is fully forced into the Headrail pocket.

Step 13

Ensure all Fascia heights are the same and that they are aligned along the bottom.

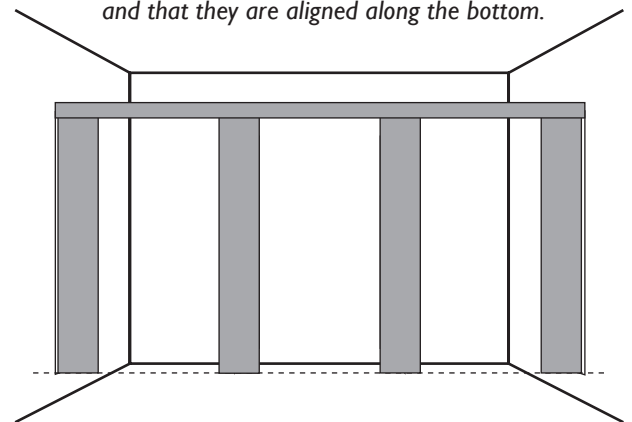

Repeat steps 11 and 12 for the other Fascias. Leave fixing the last sidewall Fascia, as it may need trimming.

Step 14

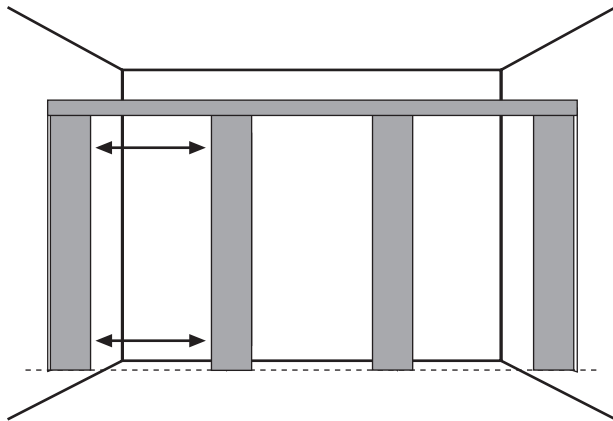

Starting with the Hinged Side Fascia, ensure that the door gap at the bottom is the same as the top gap.

When correct, fix in place by drilling a 5mm hole into the Headrail. Drilling approximately 35mm through the Headrail and panel for screw fixing (don't drill through the front of the Headrail).

Use a 5mm drill bit and (M) 12GA x 40 Panhead Screws.

Step 15

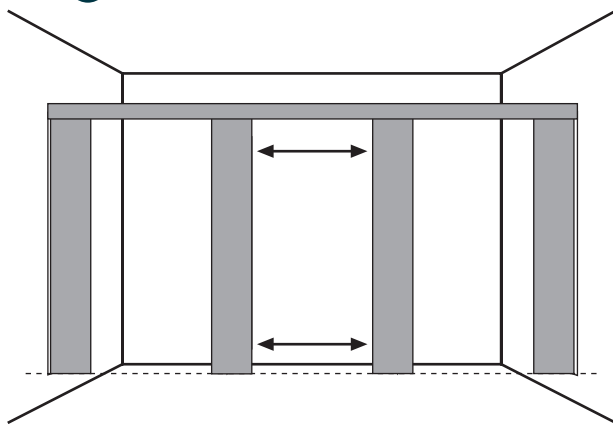

Repeat one Fascia at a time for all Fascias.

Step 16

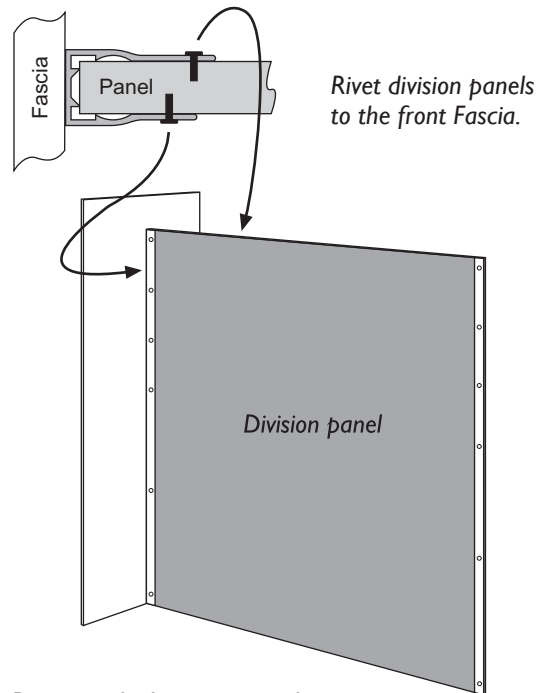

Rivet each division panel to each side of both U-Channels.

Use 3.5mm drill bit with (D) Stainless Steel Pop Rivets.

From the top down drill and rivet at 35mm, 275mm, 515mm, 755mm, 1235mm and 1715mm.

Note: To avoid rivets touching, rivet 5mm lower on the other side.

Step 17

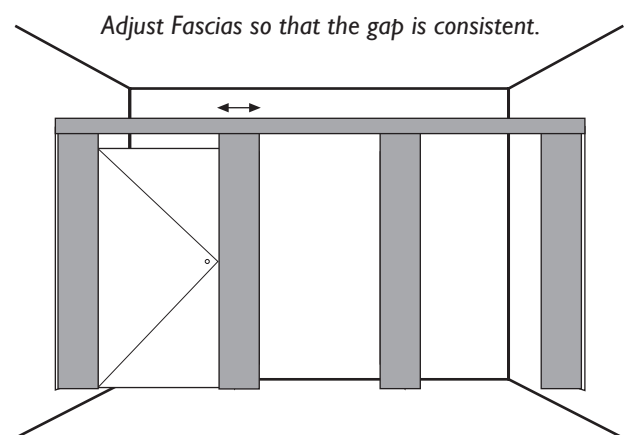

Starting from the hinge side Fascia, hang first door.

Use (B) 8GA x 12 screws.

Close door and the Fascia gaps should be consistent.

Step 18

Adjust side Fascias so that the gap is consistent.

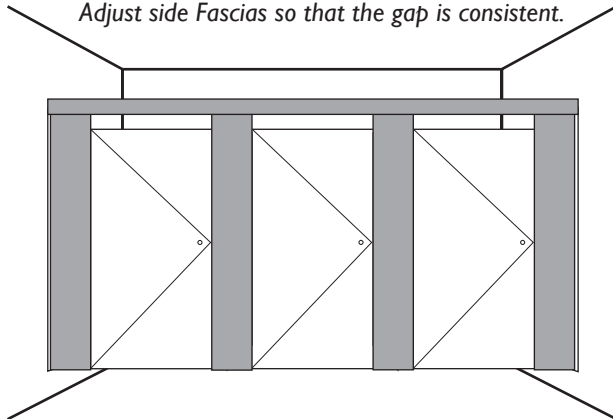

Repeat for the remaining doors.
Once gaps are consistent, fix the last Fascia.

Use (B) 8GA x 12 screws.

Step 19

Fit hardware.

Line up the coat hook with the pre-drilled holes in the doors and screw hook on.

Use (B) 8GA x 12 screws.

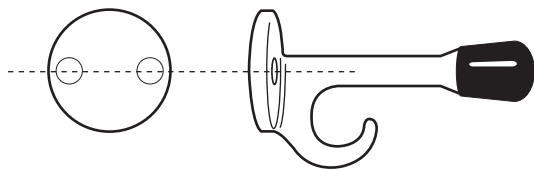

Fix the indicator bolt in the pre-drilled position.

Use the (Y) M5 x 20 tamperproof screws, with the tamperproof screwdriver.

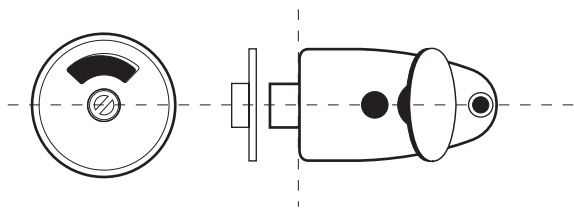

Step 20

Clean Panels

Clean all components, including pencil marks on the floor and walls.

Sweep floor and remove rubbish.

Wipe down with soapy water.

RESOCO

Resco Limited.
12 Kahu Crescent
Te Rapa Park, Hamilton 3200. New Zealand
Phone: 0800 800 950, +64 850 1025
Fax: +64 7 850 1026
(www.resco.co.nz)

©Resco March 2015