

designersplash

Colour Your World



INSTALLATION GUIDE
VERSION 2.3 | SEPTEMBER 2024

PSP MATERIALS
PRODUCTS
SOLUTIONS

TABLE OF CONTENTS

1.0	GENERAL INFORMATION	1
1.1	Introduction	1
1.2	Important Documents	1
1.3	Controlled Documents	1
2.0	DESIGN	1
2.1	Building Consent Application	1
2.2	Specification	1
2.3	Product Substitution	1
3.0	PLAN THE LAYOUT	2
4.0	PREPARATION	3
4.1	Safety and Tools	3
4.2	Handling and Storage	3
4.3	Install Plumbing in Wet Areas	3
4.4	Prepare Substrate	3
4.5	Cut Aluminum Trims	4
4.6	Cut DesignerSplash	4
4.7	Create a Dry Layout	4
5.0	INSTALLATION	5
5.1	Install Aluminum Trims	5
5.2	Provide Electrical Earthing	5
5.3	Install DesignerSplash	5
5.4	Install Fixtures	6
6.0	CARE AND MAINTENANCE	6

1.0 GENERAL INFORMATION

1.1 Introduction

DesignerSplash is a 4mm thick, impervious Aluminium Composite (ACM) panel intended for use as an internal lining. The panel comprises 0.5mm aluminium skins and a 3mm thick core of high-density mineral fibre.

DesignerSplash is supplied in a range of colours and panel sizes to suit your application:

- **750mm** x 3100mm, 750mm x 2100mm, 750mm x 900mm, 750mm x 600mm,
- **1550mm** x 3100mm, 1550mm x 2100mm

The panels are installed using a Modified Silicone (MS) Polymer High Tack Adhesive and finished using Aluminium Trims - available in anodised silver and powder-coated black.

1.2 Important Documents

In addition to this guide, PSP also supply the following documents to assist with DesignerSplash specification, installation, and maintenance:

- The Minor Variation form (where a consented internal lining is to be substituted with DesignerSplash)
- The BPIR Declaration
- Warranty - refer to PSP Terms & Conditions [Paragraph 16. Warranties and Liability](#)
- Manufacturer's Warranty - 10 Years

1.3 Controlled Documents

All documents are controlled. It is important to ensure that the current documents are always used. For documents, refer to www.psp.co.nz.

2.0 DESIGN

2.1 Building Consent Application

Where the specification of DesignerSplash is part of a building consent application, the following documentation must be submitted:

- This Installation Guide
- The BPIR Declaration

2.2 Specification

DesignerSplash is only intended for internal use and for vertical installation.

Substrate

The substrate, to which the DesignerSplash will be adhered, must be fixed to a structure that complies with the building code or to an existing structure that has the equivalent stiffness of the framing provisions for NZS 3604:2011.

DesignerSplash Installation

DesignerSplash should be fixed to the substrate using an MS Polymer High Tack Adhesive. Panel edges should be finished with Aluminum Trims or MS Polymer Sealant. Ensure that the adhesive or sealant is compatible with both the substrate and DesignerSplash.

2.3 Product Substitution

Where DesignerSplash is to be used as a substitute for the consented product, the following documentation must be supplied to the building inspector before installation of the DesignerSplash:

- The Minor Variation Form
- This Installation Guide
- The BPIR Declaration

3.0 PLAN THE LAYOUT

Planning the layout at the beginning of the project will ensure that the final installation of the panels will create the desired look and feel. It will also ensure less wastage and faster installation.

Note: Ensure that your plan is easy to follow, as it will be used at the dry layout stage.

REMEMBER:

- * DesignerSplash is only intended for internal use; for installation on vertical surfaces.
- * When used as a kitchen splashback, the panel must have a minimum 20mm setback from the side/rear edges of all hobs (incl. electric, induction, and gas). For all gas cooktops, a minimum clearance of 110mm from the edge of the open-flame gas burner is required.

ALL COOKTOPS

Minimum Clearance - 20mm

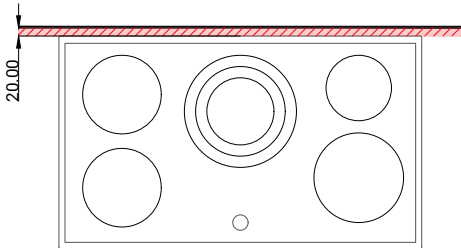

GAS COOKTOPS

Minimum Clearance - 110mm

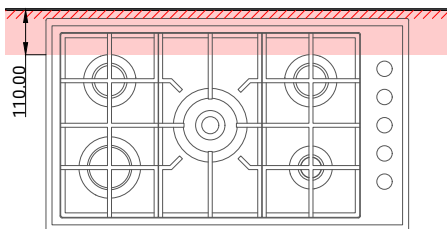

Note: DesignerSplash is not suitable for use behind cooktops with oven vents or rear heat sources. If unsure, please contact PSP.

STEP 1

Choose the panel colour and size that would best suit your DesignerSplash application.

STEP 2

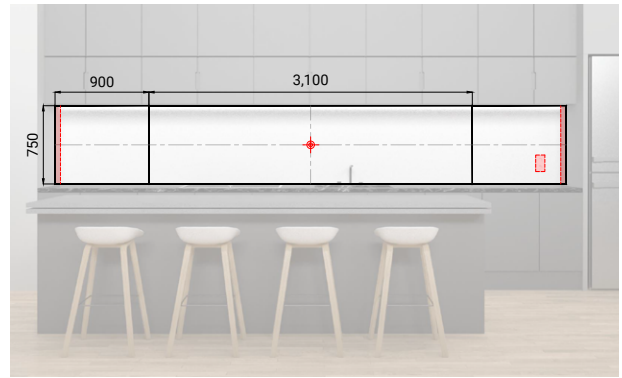

For each wall:

- Measure and mark fixtures that will affect the installation, especially electrical fixtures.
- Determine the centre of the substrate; this represents the mid-point of the layout.
- The panels will be positioned from the mid-point. Take note of panels that need to be cut, ensuring allowances for the trim installation.

Note: DesignerSplash panels have colours on both sides, ensure the correct colour faces outwards.

STEP 3

Determine trim locations and required lengths.

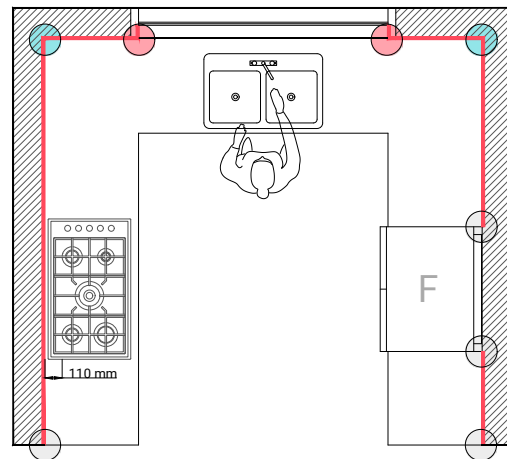

KEY	VERTICAL COMPONENT
	DesignerSplash PANELS
	WALL COMPOSITION
	EXTERNAL CORNER TRIM
	INTERNAL CORNER TRIM
	EDGE TRIM

4.0 PREPARATION

4.1 Safety and Tools

Keep Safe

Follow simple health and safety practices:

- Create a safe working environment that is well organised, tidy, and clear of obstructions.
- Always ensure PPE is worn (eye protection, gloves, dust mask, and safety footwear).
- Always operate tools and equipment strictly in accordance with the supplier's manuals.
- Regularly service tools and equipment to ensure efficient and correct operation.
- Where possible, work in an area that is well ventilated or where mechanical dust extraction is possible. This is especially important if cutting or drilling.
- Where working at height, ensure the correct selection and use of safety gear.

For further information, refer to resources at www.worksafe.govt.nz:

- Managing Health and Safety.
- Small Construction Sites, The Absolutely Essential Health and Safety Toolkit.

Skills and Tools

Competent DIYer skills and standard carpentry tools are required to install DesignerSplash. The following tools will help to simplify installation:

- Drill + Speed Drill Bits
- Scribing Knife
- Utility Knife
- Scoring Knife
- Soft-faced Mallet
- Cartridge Gun
- Table Saw
- Circular Saw
- Hole Saw
- Plunge Saw
- Jig Saw
- Hack Saw



Electric Shock Hazard: An electrician may be required where there is risk of touch voltage.

Additional Products

To install DesignerSplash, the following products may be required:

- **ALUMINIUM TRIMS** - Install trims to ensure a durable and waterproof finish. Available in anodised silver and powder-coated black.
- **ADHESIVE (BY OTHERS)** - MS Polymer Adhesive must be compatible with DesignerSplash and the substrate. High Tack adhesives are recommended for instant grab.
- **VHB TAPE (BY OTHERS)** - If a High Tack Adhesive option is unavailable, use a VHB (double-sided) Tape to hold the panel in place while the adhesive cures.
- **SEALANT (BY OTHERS)** - MS Polymer Sealant must be compatible with DesignerSplash and the substrate.
- **MASKING TAPE (BY OTHERS)**

4.2 Handling and Storage

- * Take care when transporting, handling, and storing DesignerSplash to prevent damage.
- * DesignerSplash is supplied with a protective film. Before adhering the panel to substrate, remove the film on the back. Remove the front protective film prior to applying sealant.
- * Transport and store the panels flat. Make sure that the length of panels are well supported to avoid bending and distortion.
- * Do not stack panels if they are wet. Cover in a well-ventilated area out of direct sunlight.

4.3 Install Plumbing in Wet Areas

It is important to ensure that the waterproofing is not compromised when installing plumbing. Refer to the supplier of plumbing fixtures or a licensed plumber for instructions and advice.

For general guidance, refer to [BRANZ Build 157](#). [December 2016] Penetrations in Wet Areas.

4.4 Prepare Substrate

Ensure that the substrate is level, true, and fixed soundly to the framing. Check that the substrate surface is clean, dry, and free of contaminants. If required, lightly sand or prime glossy surfaces to remove sheen.

4.5 Cut Aluminium Trims

Cut Trims to Length

Identify locations that require finishing trims; consider both vertical and horizontal edges.

Select the appropriate trim and proceed to measure, mark, and cut to necessary lengths. Aluminium trims may be cut with a hack saw or circular saw with an aluminium blade.

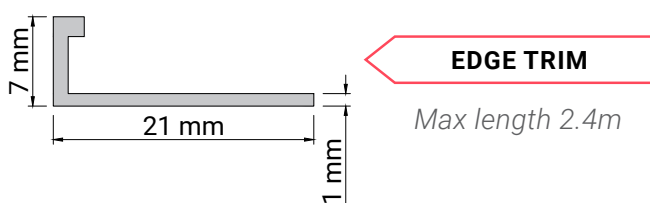
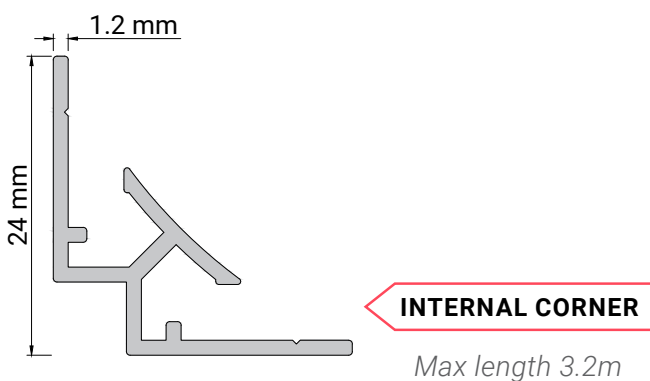
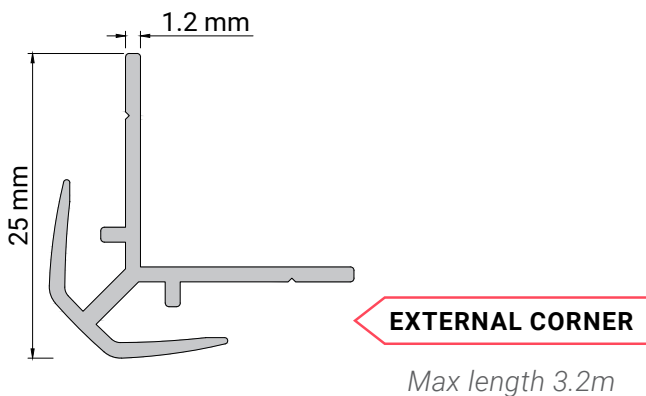

4.6 Cut DesignerSplash

Measure and mark on the DesignerSplash panel where holes and cuts are required.

Cut Panel to Size

DesignerSplash may be cut with:

- A Circular Saw (Aluminium Cutting Blade)
- A Fine-toothed Jig Saw (Aluminium Blade)
- Table Saw (Aluminium Carbide Blade)

Tip: Apply masking tape to the cut-line to protect the surface of DesignerSplash and reduce the risk of chipping and saw-induced scratches.

Circular Holes

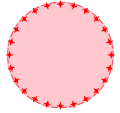
1. On the front/back side of the panel, mark the circular area to be removed. 
2. Utilise a hole saw or drill (3.5 - 5.0mm speed bit) to create a series of holes as close to each other as possible.
3. Push the waste material through and finish the opening with a utility knife.

Rectangular Holes

1. On the front/back side of the panel, mark the rectangular area to be removed.
2. Drill holes at the corners of the rectangle (15 - 18mm dia.) big enough to accommodate a fine-toothed jig saw blade. 
3. Cut the opening with a jig saw.

4.7 Create a Dry Layout

The dry layout stage is important to ensure that the final placement of DesignerSplash is square and true.

It will highlight any necessary adjustments to the substrate or if the DesignerSplash panels need trimming to align with the wall, floor, or ceiling.

5.0 INSTALLATION

5.1 Install Aluminium Trims

Follow the MS Polymer High Tack Adhesive supplier's instructions when installing the trims.



EXTERNAL & INTERNAL CORNER TRIMS

To install, apply a small bead of adhesive directly to the substrate corner or on the trim itself, then press it into place. Also, apply a bead of adhesive into each of the trim's channels to prevent water from reaching the substrate.

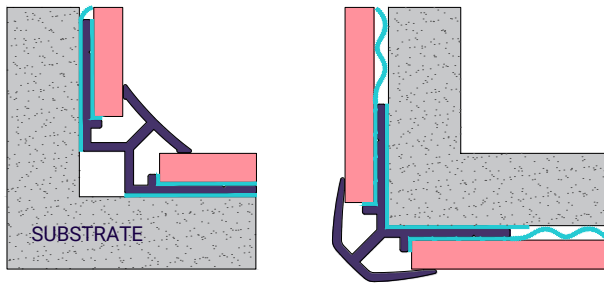

EDGE TRIM

Used in both vertical and horizontal applications at the end of panels to provide a finished look.

To install the trim, apply a small bead of adhesive directly to the substrate or on the trim itself, then press it into place. Also, apply a bead of adhesive into the trim's receiving channel.

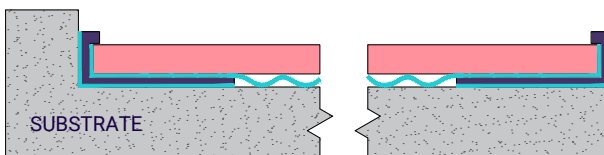

Tip: If necessary, use masking tape to temporarily secure the trim in place while the adhesive cures.

5.2 Provide Electrical Earthing

DesignerSplash features an aluminium face that is conductive of electricity. In instances involving contact with an electrical current (such as power points, light fittings, or wires), an earth connection may be required. PSP recommends seeking advice from a registered electrician.

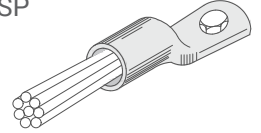

An electrician will install earthing using a crimp lug that connects to a bonding wire which runs down the back of the panels.

5.3 Install DesignerSplash

STEP 1

Before applying the MS Polymer High Tack Adhesive, remove the protective film on the back of the DesignerSplash panel, and refer to the adhesive supplier's instructions.

STEP 2

For all panels, the adhesive should be applied (on the panel or directly to the wall) as a continuous 5mm bead in a zig-zag pattern at 300mm centres.

Tip: Apply a VHB (double-sided) tape to provide additional support while the adhesive cures.

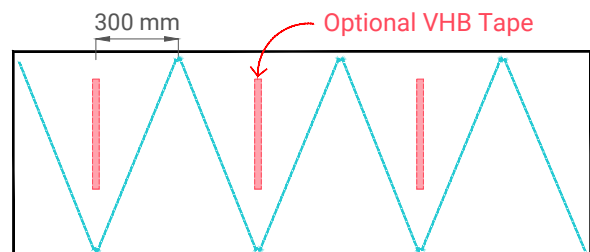

STEP 3

Apply even pressure across the panel and press it into place. Clean up any excess adhesive with a silicone remover.

STEP 4

Allow the adhesive to dry for a few minutes, then peel off the protective film from the front of the DesignerSplash panel.

STEP 5

Where the Aluminium Trims were not used, line masking tape around the edges of the panels.

Seal exposed edges with MS Polymer Sealant, applying the bead between the DesignerSplash and adjacent surface to prevent moisture penetration. Refer to the sealant supplier's instructions. Clean up any excess sealant with a silicone remover.

5.4 Install Fixtures

The adhered DesignerSplash is not strong enough to support fixtures such as shelves and shower rails. "Stick on" fixtures are not recommended, as failure may cause damage to the DesignerSplash and substrate. It is best to install fixtures through to the framing.

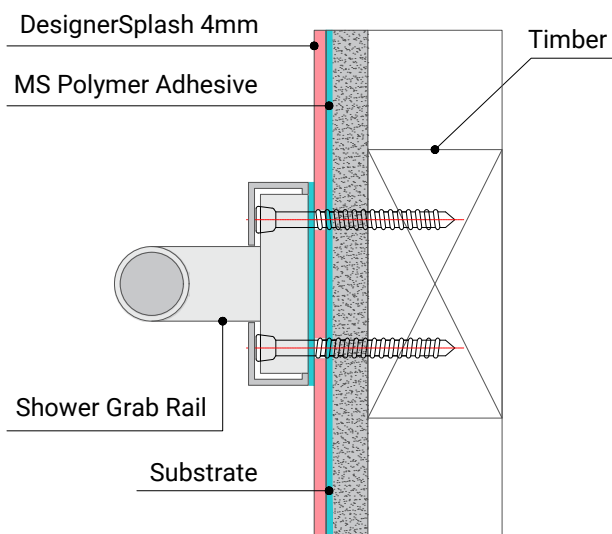

Where the panel is required to be waterproof, BRANZ recommends the following approach:
Identify, mark, and predrill the fixing location.
Before inserting the fixing, fill with sealant.
Apply sealant to the back face of the plate or bracket before fixing through the DesignerSplash to the framing.

For general guidance, refer to [BRANZ Build 157](#).
[December 2016] Penetrations in Wet Areas.

6.0 CARE AND MAINTENANCE

DesignerSplash is fully washable and should be regularly cleaned. Use a sponge with warm soapy water to remove any dirt or grime.

Do not use abrasive substances or chloride-based products or solvents.

Tip: For a natural cleaning option, use a mixture of 1 cup of vinegar and 4 cups of hot water.