

## Compliance Statement for Alucodual Cladding System

This compliance statement, produced by Oculus Architectural Engineering Limited, is an evaluation of the following product's ability to fulfil the performance requirements of the following New Zealand Building Code (NZBC) clauses based on the available performance documentation referenced below:

- B1 Structure,
- B2 Durability,
- C3 Fire Affecting Areas Beyond The Source,
- E2 Exterior Moisture

This compliance statement has been produced with the understanding that the product will be utilised in accordance with the manufacturer's details in the application described below.

### Overview

Alucodual is a pre-coated engineered sheet cladding material comprising 2 layers of laminated aluminium skins which are manufactured into panels and installed as part of a rainscreen cladding system. The multi-layer product provides for greater stiffness and rigidity than a single sheet of aluminium of similar thickness. This is advantageous for architectural applications where large spans or high levels of "flatness" are required.

Many metal panel cladding systems perform substantially similar with regard to various building code requirements. Thus, testing done with one panel, attached in a similar method will be expected to perform substantially similar to another metal panel cladding system. Where differences in properties are relevant, they are explained in the sections below.

PROPERTIES	STANDARDS	UNIT	VALUES
Panel Standard Thickness	Nominal	[mm]	2 / 2.5 / 3
Panel Standard Width	Nominal	[mm]	1250 / 1500
Panel Weight	Nominal	[kg/m <sup>2</sup> ]	5.4 / 6.8 / 8.1

**Figure 1:** Alucodual product properties

### Compliance documentation provided by The Building Agency:

- AS/NZS 4284 Test Report No. 12/16 by FMI Research Ltd – July 2012
- AS/NZS 4284 Test Report No. 14/06A by FaçadeLab – 14-16 July 2015
- AS/NZS 4284 Test Report No. 20-09a by FaçadeLab – 4-9 August 2020
- E2/VM 1 Test Report No. 14/06B by FaçadeLab – 18-19 July 2015
- CSTB - Reaction To Fire Classification Report No. Ra14-0063 according to The European Standard NF EN 13501-1+A1:2013, Reynodual – 3 November 2015.
- ISO 5660.1 2015 – AWTA Test Report 23-002688 – 14 July 2023
- Classification of reaction to fire performance in accordance with BS EN 13501-1:2018, Classification Report Reference No: XK061-2 – 19 June 2024
- Alucodual Rout & Return System Typical Installation Details
- Alucodual WAB/DAB System Typical Installation Details

## Typical product installation:

Typically, the cladding panels will be installed as part of a rainscreen cladding system. Several different panel attachment methods exist to suit any given application. This engineering judgement relates to the following typical installation methods:

- **Rout and Return System** – The rout and return system sees the panels routed along the back side and folded into an angle with fixings through adjoining folds, through a packer back to the primary structure. The joints are then sealed with PEF rod and silicone sealant.

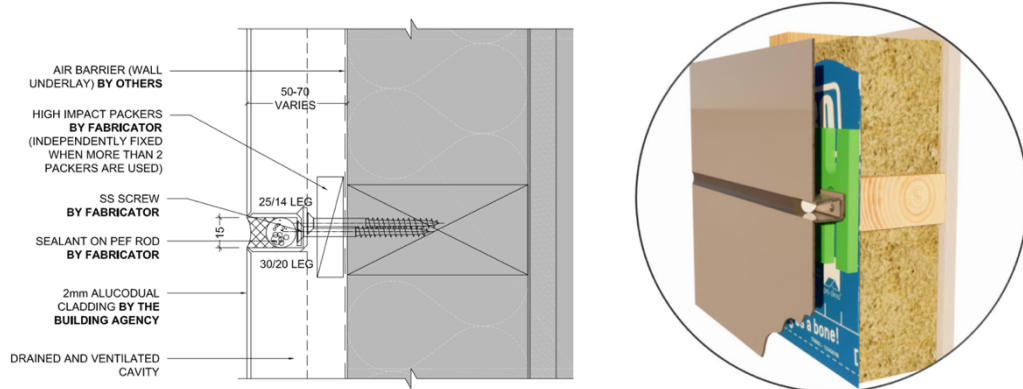

Example R&R Horizontal Joint

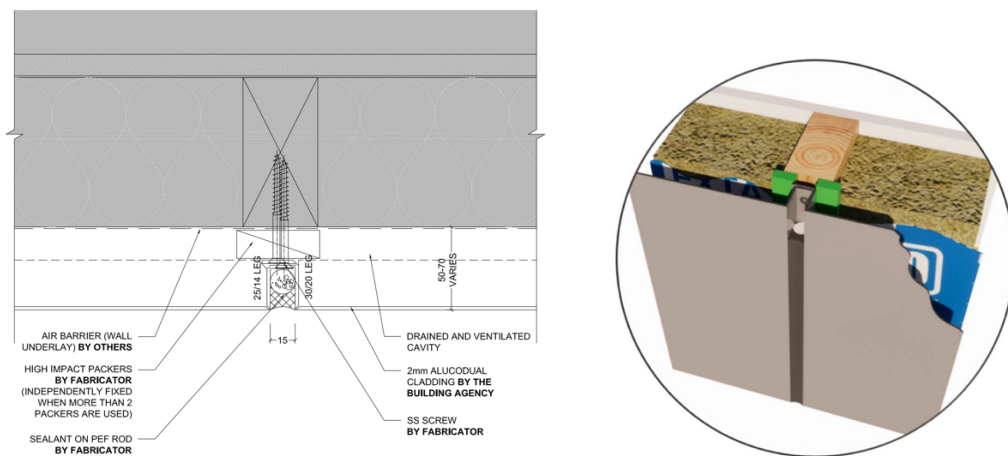

Example R&R Vertical Joint

- **WAB Extrusion System** – The WAB extrusion system utilises extruded Z angle sections that are riveted to the folded edges of the aluminium panels. These angle extrusions provide additional stiffness to the panels and help to create a drainage cavity behind the cladding panels. To secure the panels to the structural wall screws are driven through the fixing angles and into the framing behind. The joint is then sealed with PEF rod and silicone sealant.

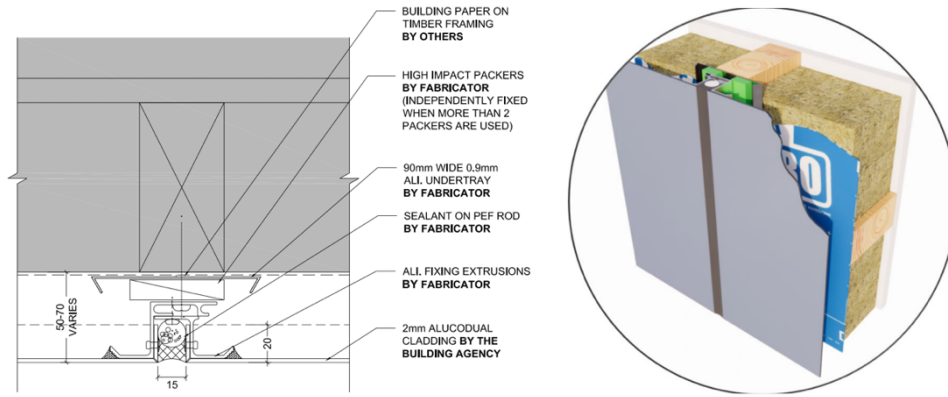

Example WAB Vertical Joint

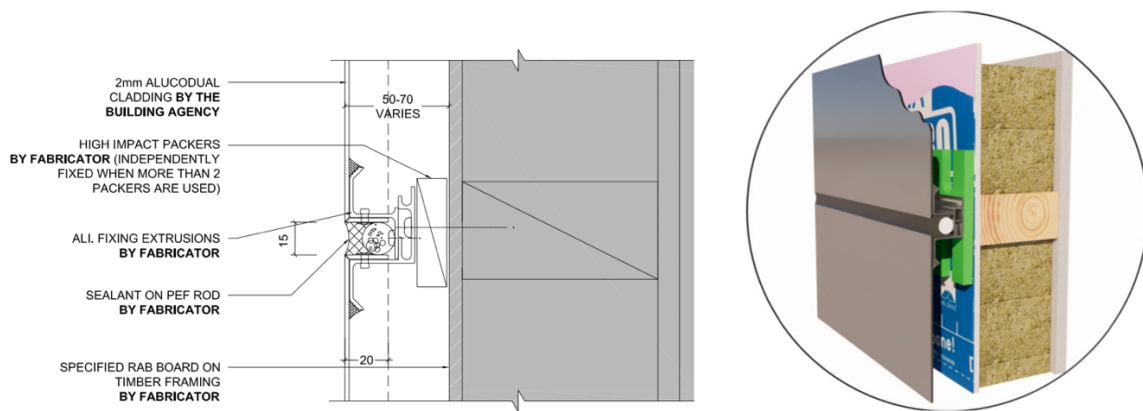

Example WAB Horizontal Joint

- DAB Extrusion System** – The DAB extrusion system is a deeper version of the WAB system. It utilises extruded Z angle sections that are riveted to the folded edges of the aluminium panels. These angle extrusions provide additional stiffness to the panels and help to create a drainage cavity behind the cladding panels. To secure the panels to the structural wall screws are driven through the fixing angles and into the framing behind. The joint is then sealed with PEF rod and silicone sealant.

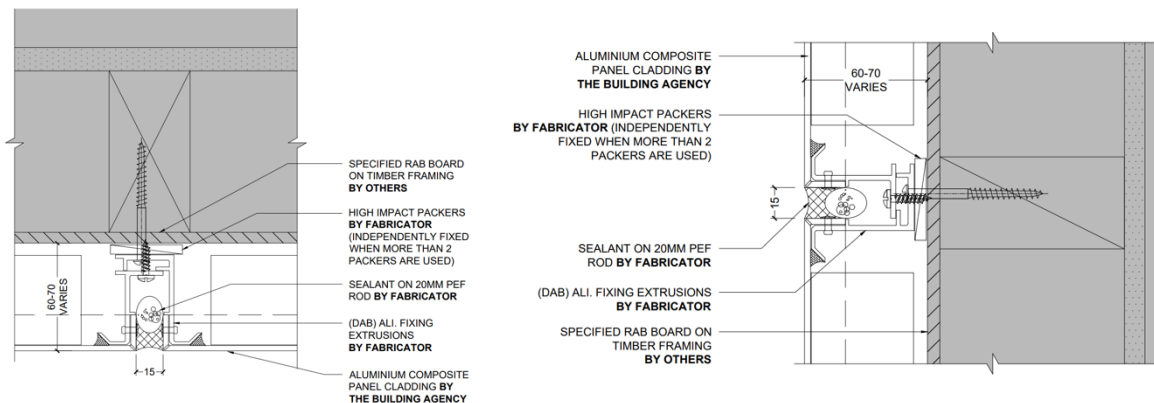

Example DAB Vertical Joint

Example DAB Horizontal Joint

## Compliance with New Zealand Building Code:

The NZBC Clauses and applicable Performance Requirements included within this compliance statement are listed in Table 1 below. Demonstration that a product or assembly can meet the Performance Requirements of the clause ensures that the Functional Requirement and the Objective of the clause will be met.

**Table 1:** NZBC Functional Requirements and Applicable Performance Requirements

NZBC	Functional Requirement	Applicable Performance Requirements
<b>B1 Structure</b>	B1.2 <i>Buildings, building elements, and site work</i> shall withstand the combination of loads that they are likely to experience during <i>construction</i> or <i>alteration</i> and throughout their lives.	B1.3.2 and B 1.3.3 a), b), f), h), m)
<b>B2 Durability</b>	B2.2 <i>Building</i> materials, components, and <i>construction</i> methods shall be sufficiently durable to ensure that the <i>building</i> , without reconstruction or major renovation, satisfies the other functional requirements of this code throughout the life of the <i>building</i> .	B2.3.1 a), b), c) and B2.3.2 a), b)
<b>C3 Fire affecting areas beyond the source</b>	C3.2 Buildings with a building height greater than 10 m where upper floors contain sleeping uses or other property must be designed and constructed so that there is a low probability of external vertical fire spread to upper floors in the building.	C3.5 and C3.7
<b>E2 External moisture</b>	E2.2 <i>Buildings</i> must be constructed to provide <i>adequate</i> resistance to penetration by, and the accumulation of, moisture from the outside.	E2.3.1 – E2.3.7

**Table 2:** NZBC Functional Requirements and Applicable Performance Requirements

NZBC Clause	Method of Compliance with Applicable Performance Requirements
<b>B1 Structure</b>	<p><b>Alternative Solution:</b></p> <p>When installed within a rainscreen cladding installation the cladding panels and supporting components must be sufficient to resist any loads imposed on the cladding system. Examples of the typical types of loads applied to the cladding system would include but are not limited to, self-weight, wind loading, &amp; seismic loading.</p> <p>Alucodual cladding panels form part of a rainscreen system are not intended to function as a primary structural element.</p>

**NZBC Clause    Method of Compliance with Applicable Performance Requirements**

**Wind:**

Two aspects of the system are considered:

1. Capacity of fastening system (rails/fasteners)
2. Panel deflection under SLS and ULS wind loads

A similar system (Alucobond/Alucolux) has been subjected to AS/NZS 4284 testing which includes testing of the cladding systems performance under a differential air pressure to simulate wind loading. In a typical assembly the air barrier is created behind the cladding line at the back of the rainscreen cavity. The cavity itself typically features openings for drainage and ventilation that enable the space behind the cladding line to pressure equalize with the environment and therefore any wind pressure effectively resisted by the air barrier behind.

In theory, this approach should result in a minimal wind pressure being applied to the cladding itself. AS/NZS 4284 testing included the Alucobond panel system being tested to ULS pressures in excess of 3.6 kPa. This testing was done with the rigid air barrier in place which is representative of how the system is installed in the field. Testing of the system up to these pressures resulted in no structural damage or collapse.

During a further AS/NZS 4284 test, the air barrier was partially removed to evaluate how the panel deflects under a conservative wind load and test the capacity of the fixings should failure of the air barrier occur. During this test the Alucobond cladding system was subjected to the following pressures:

- Maximum positive pressure = 2000 Pa
- Maximum negative pressure = 1500 Pa

During this test the report notes that no structural failure of the panel or fasteners occurred. While the panels did deflect under the applied load it appears the deflection remained elastic, and the panels returned to their original positions following the removal of the load. However, the rigidity of the tested panels differs from the Alucodual panels, therefore stiffener spacing design for the Alucodual panels is to be undertaken on a project-specific basis.

**Seismic:**

During a seismic event, the panels are expected to be subjected to a minor seismic load due to their relatively low weight. The panels are not expected to withstand any additional seismic loads other than their own inertia. However, the panels and support system must be able to accommodate the movement of the buildings structure during a seismic event without

NZBC Clause	Method of Compliance with Applicable Performance Requirements
	<p>detaching from the building or without permanent damage for lower intensity seismic events.</p> <p>As part of the AS/NZS 4284 test regime, the cladding assembly was subject to a seismic racking test. The test was conducted by pushing on the top of the backup wall assembly with a hydraulic ram. The test assembly was subject to two tests. The first an SLS seismic movement test of ±20mm and the second a ULS seismic movement of +88mm (the maximum travel the ram could achieve).</p> <p>Following both tests the report notes that no structural damage to the cladding system was observed. As a result, we are confident that the cladding system is suitable to accommodate inter-storey movements of 0.5% without damage from the SLS test. We note that based on the results of the test report we believe that larger seismic movements will also be accommodated by the system without detachment of the cladding panels.</p> <p>As before, while the Alucodual panel was not featured in the test referenced above, we are satisfied that, given the nature of the Alucodual product, and its similarities with the Alucobond product, it will perform comparably in regard to structural performance to what was observed in the AS/NZS 4284 test of the Alucobond/Alucolux panels.</p> <p>Based on the information contained above we believe that this product will fulfill the performance requirement clauses of B1 up to the following limits:</p> <ul style="list-style-type: none"> <li>• <b>Wind loads:</b> ULS 3.6 kPa</li> </ul>
B2 Durability	<p><b>Alternative Solution</b></p> <p>Alucodual is made from 2 layers of 5005 series marine-grade aluminium sheet.</p> <p>Unfinished aluminium is, by its nature, inherently durable. The aluminium forms a stable oxide layer upon contact with the atmosphere which seals the raw aluminium below from further oxidation. Unlike galvanised coatings which are sacrificial and do, in turn, react with the environment, the oxide layer formed on aluminium is stable and does not degrade in contact with the atmosphere under the conditions expected to be experienced in use.</p> <p>Aluminium for architectural use commonly has a surface finish applied which can greatly enhance the durability of the product. The Alucodual cladding panels feature a high-performance coil-</p>

NZBC Clause	Method of Compliance with Applicable Performance Requirements
-------------	---

coated PVDF paint system to AAMA 2605 which is accepted for use up to exposure zone C5 per ISO 9223: 2012 (comparable to exposure zone E per E2/AS1).

The panels are coil coated using an in-line, 3-coat fluorocarbon based PVDF system. The rear aluminium sheet face has a polyester-based service coat. The coil coating process is a continuous automated process used to coat sheet metal products before fabrication into a finished product. The process typically combines cleaning, priming, application of paint finish and packaging back into coils in one production line.

This process offers significant quality control benefits where the consistency of the finish is ensured and handling between processes is eliminated. The polyvinylidene fluoride (PVDF) coating is non-reactive and resistant to solvents, acids, and other environmental pollutants. As a result, the coating should not be affected by airborne contaminants encountered in service. In addition, the increased wear resistance means the product should remain durable throughout the service life of the panel.

In addition to the panels, the cladding rails and fixings are also manufactured from aluminium or stainless steel. Both aluminium and stainless steel are included in E2/AS1 Table 20 which indicates they are suitable for use as "hidden" cladding/flashing materials with a required durability of 50 years, up to and including exposure zone E (severe). Therefore, they are expected to easily remain serviceable throughout the expected service of the cladding system.

Please note, specific design is required if microclimatic conditions, such as geothermal hotspots, industrial, agricultural, or chemical environments, etc, exist.

Based on the information contained above we believe that this product will fulfill the performance requirements clauses of B2:

- **B2.3.1** *"Building elements must, with only normal maintenance, continue to satisfy the performance requirements of this code for the lesser of the specified intended life of the building, if stated, or:"*
  - (b) *"15 years"*
- **B2.3.2** *"Individual building elements which are components of a building system and are difficult to access or replace must either:"*
  - (a) *"All have the same durability"*



NZBC Clause	Method of Compliance with Applicable Performance Requirements
E2 External Moisture	<p><b>Alternative solution:</b></p> <p>The cladding products listed above are intended to be installed as part of a rainscreen cladding system where the panels form the outermost water shedding layer. In the completed wall assembly, the weather resistant line is located at the back of the rainscreen cavity provided by a flexible building wrap or rigid air barrier. In a system like this, the cladding line is expected to deflect the majority of the water hitting the façade.</p> <p>Where water does penetrate the cladding line, the cavity between the cladding and structural wall is expected to prevent water being able to migrate onto the structural wall and allow water to drain down towards the midfloor where flashings direct the water out past the cladding line. These openings at each level encourage ventilation which aid drying of any residual water in the cavity and drying of the structural wall should these other weathertightness measures fail.</p> <p>In addition, similar aluminium sheet cladding products (Alucobond), have been tested to the AS/NZS 4284 standard which includes water penetration testing. During testing, the test assembly was subject to two water penetration tests. The first, a static water penetration test whereby the tested system was subject to a positive static wind pressure of 750 Pa. The second test was conducted under a cyclic wind loading condition with pressures between 750 Pa and 1500 Pa.</p> <p>In all instances the test report notes that “no water penetration” was observed during testing.</p> <p>Although testing was undertaken on a different product by the same manufacturer, the rail attachment system and detailing are essentially identical to the proposed system, therefore the Alucodual system is expected to perform in a similar manner.</p> <p>Based on the information contained above we believe that this product will fulfill the performance requirements clauses of E2:</p> <ul style="list-style-type: none"> <li>• <b>E2.3.2</b> <i>“Roofs and exterior walls must prevent the penetration of water that could cause undue dampness, damage to building elements, or both.”</i></li> <li>• <b>E2.3.3</b> <i>“Walls, floors, and structural elements in contact with, or in close proximity to, the ground must not absorb or transmit moisture in quantities that could cause undue dampness, damage to building elements, or both.”</i></li> <li>• <b>E2.3.5</b> <i>“Concealed spaces and cavities in buildings must be constructed in a way that prevents external moisture being</i></li> </ul>



NZBC Clause	Method of Compliance with Applicable Performance Requirements
	<p><i>accumulated or transferred and causing condensation, fungal growth, or the degradation of building elements."</i></p> <ul style="list-style-type: none"> <li>• <b>E2.3.6</b> <i>"Excess moisture present at the completion of construction must be capable of being dissipated without permanent damage to building elements."</i></li> <li>• <b>E2.3.7</b> <i>"Building elements must be constructed in a way that makes due allowance for the following:"</i> <ul style="list-style-type: none"> <li>◦ <b>(a)</b> <i>"the consequences of failure"</i></li> </ul> </li> </ul>
<p><b>C3 Fire affecting areas beyond the source</b></p>	<p><b>Alternative solution:</b></p> <p>To demonstrate compliance with NZBC C3.5 and C3.7, the external wall cladding system must be classified as "non-combustible" or "limited combustible" materials, as defined in C/AS1, C/AS2, C/VM1. Specifically:</p> <p><b><u>Non-combustible:</u></b>  A material either –</p> <ul style="list-style-type: none"> <li>a) composed entirely of glass, concrete, steel, brick/block, ceramic tile, or aluminium; or</li> <li>b) classified as non-combustible when tested to AS 1530.1; or</li> <li>c) classified as A1 in accordance with BS EN 13501-1.</li> </ul> <p><b><u>Limited combustible:</u></b>  A material that does not comply with the requirements for a non-combustible material and is classified as A2 in accordance with to BS EN 13501-1.</p> <p>Alucodual is classified as Class A2-s1, d0 according to BS EN 13501-1 and is therefore defined as <u>a material of limited combustibility</u>. The rail system is composed entirely of aluminium or stainless steel and is therefore defined as a non-combustible material. Based on the above, the Alucodual cladding system can be considered compliant with clauses C3.5 and C3.7 for use as a wall cladding material.</p> <p><b>Note:</b> The statements contained above pertain to the Alucodual cladding panels and associated rails. These elements will form part of a broader wall system. The full wall system must be assessed for combustibility and compliance with C3.5 and C3.7.</p>

## Compliance Statement and Limitations

The evidence above shows the system is capable of achieving the requirements of the building code. The systems need to be incorporated by reasonable and competent designers to form project specific details; however, if good design principles are implemented, we see no reason the system could not achieve the requirements of the building code as outlined above.

Regards,



Emily Livesey  
Building Enclosure Engineer

Reviewed by:



Shawn McIsaac, CPEng (NZ, Aus), P.E. (Wa) PEng. (BC)  
Director, Senior Building Enclosure Engineer  
Oculus Architectural Engineering Ltd.