



YF Series Commercial Heat Pump Range



Rheem commercial heat pumps have just set the new standard, now with GWP <1, improved COP, higher hot water delivery temperature and better low ambient operation.

AIR TO WATER HEAT PUMP



HEAT PUMP



HOT WATER
TO 65°C



<1 GWP



LOW AMBIENT
OPERATION

WHERE ULTRA-LOW CARBON FOOTPRINT IS ESSENTIAL

Up to 65°C hot water delivery to the building with ultra-low GWP and improved COP.

ULTRA-LOW GWP

Rheem YF Series commercial heat pumps employ R1234yf refrigerant which has an ultra-low global warming potential (GWP) rating of <1, combined with an improved co-efficient of performance (COP), making it the prime choice where ESD requirements are paramount.

Available in Air to Water (A2W) and Water to Water (W2W) models in nominal 15kW and 30kW outputs.

IMPROVED COP

Detailed engineering has tuned the average COP of the A2W models up to 4.28 for the 30kW model and 4.23 for the 15kW model. Further product enhancement allows the heat pump to operate in ambient conditions to a low of 0°C, reducing the reliance on auxiliary heating methods, thereby improving overall annual efficiency.

MULTIPLE INSTALLATION OPTIONS

A2W models are designed with both vertical and horizontal discharge options, with fan options available in ducted and non-ducted versions. Horizontal discharge models can also be stacked two high to reduce plant footprint.

FURTHER PRODUCT IMPROVEMENTS

Efficiency has been improved with the use of variable speed Electronically Commutated fans and an upgraded micro-controller now allows up to six 15kW heat pumps to be inter-linked for common BMS connectivity in Modbus

or BACnet (interface card required). This also allows for optional staging and rotation on a lead/follower basis for further energy reduction and product life improvement.

The 30kW model has dual controller and refrigerant circuits providing 50% redundancy in a single unit package.

An electronic expansion valve improves performance by accurately metering the correct amount of refrigerant and reverse cycle de-ice provides rapid de-icing in low ambient environments improving recovery.

STANDARD RHEEM FEATURES

The features that make Rheem the first choice in heat pump technology are still maintained, including:

- Marine grade aluminium cabinet that won't rust
- Evaporator coils fully dipped with Rheemkote® as standard, meeting 10,000hr neutral salt spray test for superior corrosion protection

- Rheem iQ controller monitors 9 operating parameters providing on-board diagnostics and BMS input – improved reliability and servicing
- Auxiliary boost interlock – when activated, only operates in extreme low ambient conditions or when >50% of the heat pumps are in fault – surety of hot water supply
- Fully certified including Electrical Safety, EMC and Water Mark – confidence in your selection
- Tested in ambient conditions as high as 45°C – built for the Australian and New Zealand climates
- Rheem has been leading the way in commercial heat pump technology since 2008 supported by an in-house service team, with local technical support



*Conditions apply: For full terms and conditions please contact Rheem or visit rheem.co.nz/support/commercial-warranties/

TECHNICAL DATA

AIR TO WATER					
PRODUCT DATA		Ducted Exhaust	Non-Ducted Exhaust	Ducted Exhaust	Non-Ducted Exhaust
MODEL		952015	953015	952030	953030
Heating Capacity ²	kW	15.16	15.16	29.78	29.78
Power Input ²	kW	3.87	3.58	7.11	6.96
Coefficient of Performance COP ²		3.92	4.23	4.19	4.28
Recovery @ 50°C Rise ²	L/hr	261	261	512	512
Operating Range (ambient)	°C	0 - 45			
Maximum DHW Temperature ¹	°C	65			
Refrigerant		R1234yf			
Refrigerant Mass	kg	2.25	2.25	4.5 ⁴	4.5 ⁴
Hot Water Side					
TPR Valve Setting (VE/RT/RW)	kPa	1000 / 850 / 700			
ECV Setting (VE/RT/RW) ³	kPa	860 / 700 / 550			
Maximum Water Supply Pressure					
- Without ECV (VE/RT/RW)	kPa	800 / 680 / 550			
- With ECV (VE/RT/RW)	kPa	680 / 550 / 450			
Design Flow Rate	L/s	1.1	1.1	2.2	2.2
Design Pressure Drop	kPa	40	40	50	50
Heat Exchanger Design	0/V	00/H0 = 316 Stainless Steel Double Wall Brazed Plate / 0V/HV = Copper Tube in Tube Vented			
Air Side					
Air Flow (at maximum static pressure)	L/s	1972	1972	3750	3750
Maximum Static Pressure	Pa	63	5	37	5
Minimum Free Air Ventilation per inlet and outlet	m ²	2	2	4	4
Electrical Connection					
Power Supply		3 Phase / 380-415V / 50 Hz			
Max Current per Phase (running, incl pump)	Amps	14.4	12.5	23.2	23
Max Pump Current	Amps	2.4	2.4	4.4	4.4
Minimum Circuit Breaker size (per phase)	Amps	20	20	40	40
Installation Data					
Approx Weight Empty	kg	120	120	260	260
Approx Weight Full	kg	125	125	270	270
Sound Pressure Level @3m	dBa	69	61	69	67
Clearances					
Evap Coil Side	mm	350	350	500	500
Back (vertical discharge models)	mm	Nil	Nil	Nil	Nil
Back (horizontal discharge models)	mm	1200	1200	2000	2000
Display Side	mm	850	850	850	850
Water Connection Side	mm	600	600	600	600
Top (vertical discharge models)	mm	1200	1200	2000	2000
Top (horizontal discharge models)	mm	Clearance above unit required for service personnel to stand			

1 When ambient temperature is not likely to drop below 5°C during operation.

2 20°C ambient / 60%RH, 39°C water in / 42°C water out.

3 ECV not supplied with water heater.

4 2 circuits at 2.25kg each.

AIR TO WATER 15KW MODEL RECOVERY

Ambient Temperature °C	0	5	10	15	20	25	30	35	40	45
Output (kW)	9.54	10.68	12.38	13.62	15.16	15.95	16.46	16.98	19.10	19.78
Recovery – Litres per hour										
20°C rise	410	459	532	586	652	686	708	730	821	851
25°C rise	328	367	426	469	522	549	566	584	657	680
30°C rise	273	306	355	390	435	457	472	487	548	567
35°C rise	234	262	304	335	373	392	404	417	469	486
40°C rise	205	230	266	293	326	343	354	365	411	425
45°C rise	NA	204	237	260	290	305	315	325	365	378
50°C rise	NA	184	213	234	261	274	283	292	329	340
55°C rise	NA	NA	194	213	237	249	257	266	299	309

AIR TO WATER 30KW MODEL RECOVERY

Ambient Temperature °C	0	5	10	15	20	25	30	35	40	45
Output (kW)	19.82	22.03	24.89	27.40	29.78	32.09	33.11	34.15	36.33	39.81
Recovery – Litres per hour										
20°C rise	852	947	1070	1178	1281	1380	1424	1468	1562	1712
25°C rise	682	758	856	943	1024	1104	1139	1175	1250	1369
30°C rise	568	632	714	785	854	920	949	979	1041	1141
35°C rise	487	541	612	673	732	789	814	839	893	978
40°C rise	426	474	535	589	640	690	712	734	781	856
45°C rise	NA	421	476	524	569	613	633	653	694	761
50°C rise	NA	379	428	471	512	552	569	587	625	685
55°C rise	NA	NA	389	428	466	502	518	534	568	622

15kW A2W COP and Heating Capacity

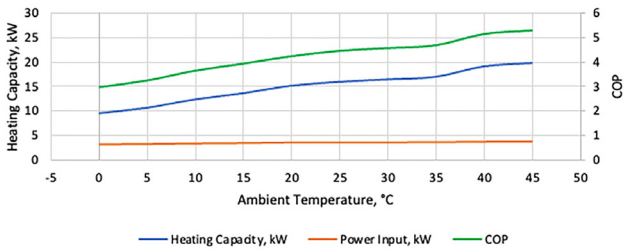

30kW A2W COP and Heating Capacity

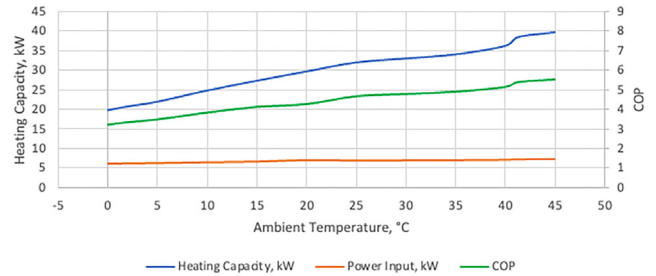

Typical installation

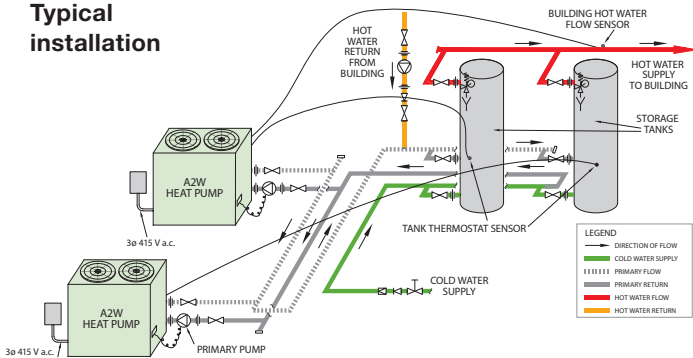

PUMP AND PIPE SIZING CHART

	15kW				30kW			
	1	2	3	4	1	2	3	4
Number of Heat Pumps in Parallel	1	2	3	4	1	2	3	4
Primary Pump	Grundfos CM3-2				Grundfos CM10-1			
Branch Size	40				50			
Header Size	40	50	65	80	50	80	100	100

ACCESSORIES

Storage Tank	Pump 15kW	Pump 30kW	BMS Card	LAN Cable
410L (VE)			17520- BACnet TCP/IP	17670
1000 to 5000 (RT 316L-SS)	CM3-2 366084	CM10-1 366094	17521- BACnet MS/TP	
1000 to 3000L (RW 2205-SS)			17522- Modbus RS485	

WATER TO WATER HEAT PUMP



HEAT PUMP



WASTE HEAT RECOVERY



<1 GWP



UP TO 7.0 COP EFFICIENCY

CONNECT TO BUILDING CONDENSER LOOP FOR EXCEPTIONAL COP PERFORMANCE

High heating output with ultra-low GWP and exceptional COP.

The Rheem Water to Water (W2W) heat pump has captured the imagination of system designers as a compact system that can be installed virtually anywhere with with a COP up to 7. And is now available in R1234yf refrigerant with a GWP of <1 providing exceptional carbon footprint reduction.

SIZING RE-IMAGINED

With the ability to produce up to 63% more hot water than the equivalent A2W version when connected to a 35°C condenser circuit, heat pump sizing is turned on it's head, providing the ability for more recovery kW and less storage with reduced complexity, plant footprint and weight.

PRODUCT ENHANCEMENTS

The evaporator heat exchanger is now copper tube-in-tube, suited to the conditions found in HVAC condenser circuits and an upgraded micro-controller now allows up to six 16kW heat pumps to be inter-linked for common BMS connectivity in Modbus or BACnet (interface card required). This also allows for optional staging and rotation on a lead/follower basis for further energy reduction and product life improvement.

The 32kW model has dual controller and refrigerant circuits providing 50% redundancy in a single unit package.

STANDARD RHEEM FEATURES

The features that make Rheem the first choice in heat pump technology are still maintained, including:

- Marine grade aluminium cabinet – won't rust
- Copper tube-in-tube evaporator heat exchanger – better suited to HVAC condenser circuits
- Rheem iQ controller monitors 11 operating parameters providing on-board diagnostics and BMS input – improved reliability and servicing
- Auxiliary boost interlock – when activated, only operates if chiller circuit is off or when >50% of the heat pumps are in fault – surety of hot water supply
- Double stack capability as standard – halves footprint
- Fully certified including Electrical Safety, EMC and Water Mark – confidence in your selection
- Rheem has been leading the way in commercial heat pump technology since 2008 supported by an in-house Service team, with local technical support



Typical installation

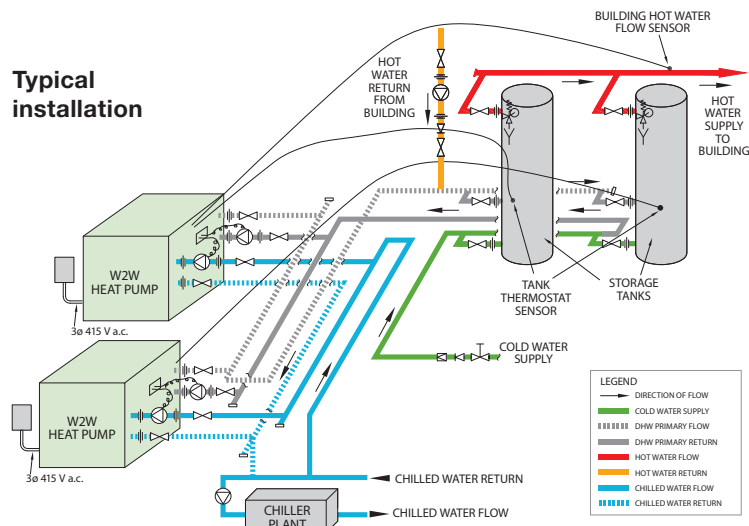

*Conditions apply; For full terms and conditions please contact Rheem or visit rheem.co.nz/support/commercial-warranties/

TECHNICAL DATA

WATER TO WATER			
MODEL		955016	955032
Nominal Heating Capacity at 20°C Cold Water Temperature ¹	kW	16.04	32.09
Nominal Cooling Capacity at 20°C Cold Water Temperature ¹	kW	12.97	25.94
Nominal Heating Capacity at 35°C Cold Water Temperature ²	kW	23.11	46.22
Power Input ²	kW	3.07	6.15
Coefficient of Performance (Heating) at 20°C Cold Water Temperature ¹	°C	5.22	5.22
Coefficient of Performance (Cooling) at 20°C Cold Water Temperature ¹	°C	4.22	4.22
Coefficient of Performance (Heating) at 35°C Cold Water Temperature ²	°C	6.9	6.9
Maximum Stored DHW Temperature	°C	65	
Refrigerant		R1234yf	
Refrigerant mass	kg	2	4 ⁴
Hot Water Side			
TPR Valve Setting (VE/RT/RW)	kPa	1000 / 850 / 700	
ECV Setting (VE/RT/RW) ³	kPa	860 / 700 / 550	
Maximum Water Supply Pressure			
- Without ECV (VE/RT/RW)	kPa	800 / 680 / 550	
- With ECV (VE/RT/RW)	kPa	680 / 550 / 450	
Hot Water Side Design Flow Rate	L/s	1.2	2.39
Heating Design Temperature Difference	°K	3.2	3.2
Heat Exchanger Design	0/V	00 = 316 Stainless Steel Double Wall Brazed Plate / 0V = Copper Tube in Tube Vented	
Design Pressure Drop	kPa	50	50
Cold Water Side			
Maximum Water Supply Pressure	kPa	1000	1000
Cold Water Side Design Flow Rate	L/s	1.41	2.82
Cooling Design Temperature Difference	°K	2.2	2.2
Heat Exchanger Design		Single Wall Copper Shell in Tube	
Design Pressure Drop	kPa	50	50
Electrical Connection			
Power Supply		3 Phase / 380-415V / 50Hz	
Max Current per Phase (running, excl pumps)	Amps	9.6	19.3
Max Pump Current (allow for 2 x pumps per heat pump)	Amps	2 x 2.4	2 x 4.4
Minimum Circuit Breaker size (per phase)	Amps	20	40
Installation Data			
Approx Weight Empty	kg	125	250
Approx Weight Full	kg	130	260
Sound Pressure Level @3m	dBa	59	62
Clearances			
Front	mm	850	
Back	mm	Nil	
Water Connection Side	mm	500	
RH Side	mm	Nil	
Top	mm	Clearance required for personnel to stand	

¹ Rating Conditions: Heating 39°C water in, 42°C water out, 51°C SCT, Cold 12°C water in, 7°C water outlet, 2°C SST.

² Rating Conditions: Heating 39°C water in, 42°C water out, 51°C SCT, Cold 35°C water in, 29.5°C water outlet, 10°C SST.

³ ECV not supplied with water heater.

⁴ 2 circuits at 2kg each.

WATER TO WATER 16kW MODEL RECOVERY

Cold Water Side Temperature (°C)	12	14	16	18	20	25	30	35
Output (kW)	12.44	13.27	14.14	15.07	16.04	18.73	21.78	23.11
Recovery – Litres per hour								
20°C rise	535	571	608	648	690	805	937	994
25°C rise	428	456	486	518	552	644	749	795
30°C rise	357	380	405	432	460	537	624	662
35°C rise	306	326	347	370	394	460	535	568
40°C rise	267	285	304	324	345	403	468	497
45°C rise	238	254	270	288	307	358	416	442
50°C rise	214	228	243	259	276	322	375	397
55°C rise	195	207	221	236	251	293	341	361

WATER TO WATER 32kW MODEL RECOVERY

Cold Water Side Temperature (°C)	12	14	16	18	20	25	30	35
Output (kW)	24.89	26.54	28.28	30.13	32.09	37.45	43.56	46.22
Recovery – Litres per hour								
20°C rise	1070	1141	1216	1296	1380	1610	1873	1987
25°C rise	856	913	973	1036	1104	1288	1498	1590
30°C rise	714	761	811	864	920	1074	1249	1325
35°C rise	612	652	695	740	789	920	1070	1136
40°C rise	535	571	608	648	690	805	937	994
45°C rise	476	507	540	576	613	716	832	883
50°C rise	428	456	486	518	552	644	749	795
55°C rise	389	415	442	471	502	586	681	723

PUMP AND PIPE SIZING CHART (HOT SIDE AND COLD SIDE)

	16kW				32kW			
	1	2	3	4	1	2	3	4
Number of Heat Pumps in Parallel	1	2	3	4	1	2	3	4
Primary Pump	Grundfos CM3-2				Grundfos CM10-1			
Branch Size	40				50			
Header Size	40	50	65	80	50	80	100	100

ACCESSORIES

Storage Tank	Pump 16kW	Pump 32kW	BMS Card
410L (VE)	CM3-2 366084	CM10-1 366094	17520 - BACnet TCP/IP
1000 to 5000L (RT 316L-SS)			17521 - BACnet MS/TP
1000 to 3000L (RW 2205-SS)			17522 - Modbus RS485

16kW W2W COP and Heating Capacity

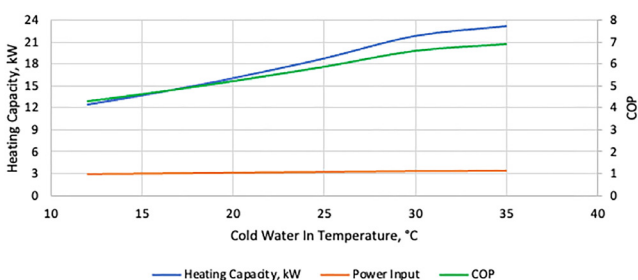

32kW W2W COP and Heating Capacity

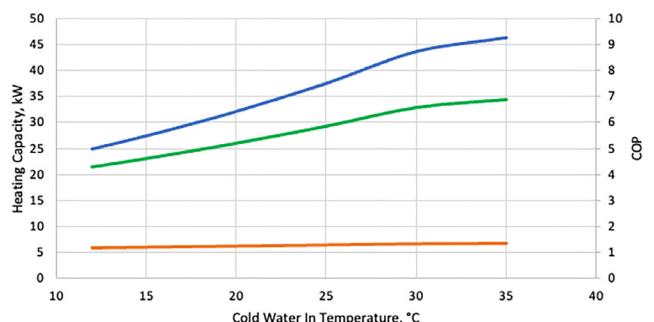

A2W Vertical Discharge 15kW and 30kW

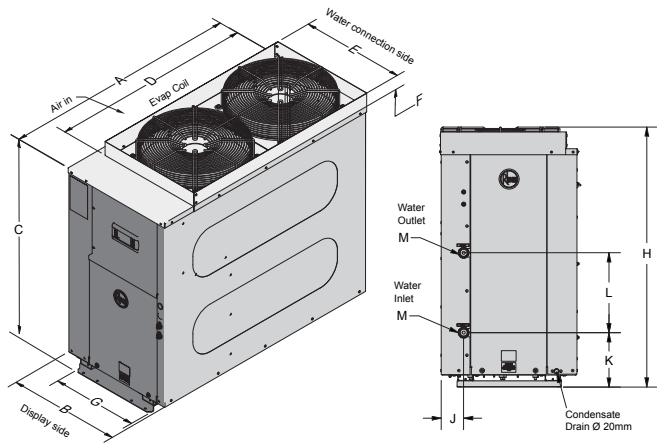

DIMENSIONS A2W				
Model	15kW		30kW	
Dimension	Vertical	Horizontal	Vertical	Horizontal
A	1200	1200	1850	1882
B	565	565	807	807
C	984	1033	1290	1339
D (952 models)	1010	806	1452	1385
E (952 models)	521	928	725	992
F (952 models)	90	70	90	90
G	429	429	675	675
H	1049	654	1404	944
J	92	416	139	230
K	199	199	199	199
L	330	330	330	330
M	R1¼	R1¼	R2	R2

A2W Horizontal Discharge 15kW and 30kW

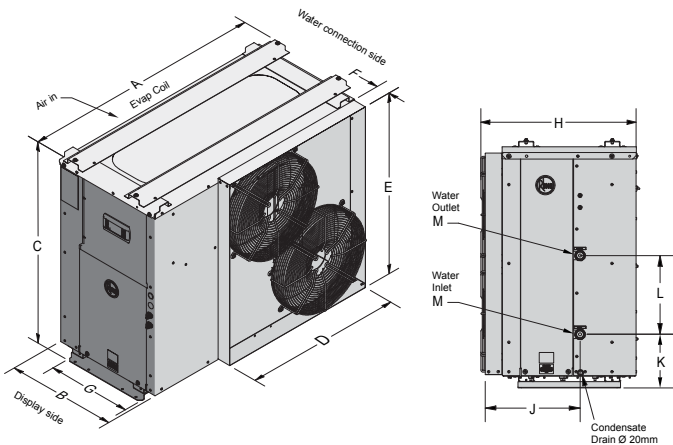

DIMENSIONS W2W		
Model	16kW	32kW
Dimension		
A	1051	1600
B	605	605
C	924	924
D	66	66
E	342	139
F	66	66
H	972	972
J	65	65
K	123	99
L	330	170
M	R1¼	R2
N	65	65
P	123	123
Q	220	400

W2W 16kW and 32kW

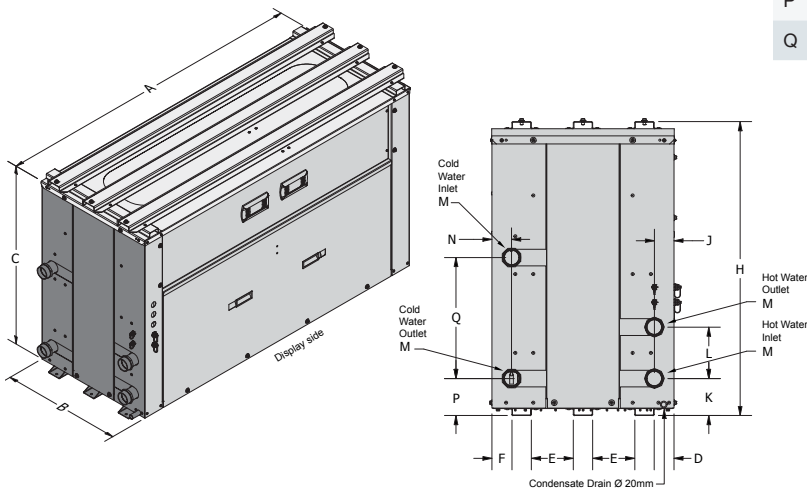

Install a Rheem®

Rheem New Zealand Limited

475 Rosebank Road, Avondale 1026, PO Box 19011, Avondale, Auckland 1746. Freephone 0800 657 336 – www.rheem.co.nz
 All specifications contained in this brochure are subject to change without notice. Please check the specifications are current at the time of ordering. All information is current at the time of publication (9 October 2023).