



# INSTALLATION GUIDE

V1.0 May 2022

## General and product information

### PRODUCT DESCRIPTION

UNI and UNI PLUS are nonwoven, absorbent, water-resistant, 180 GSM, synthetic wall underlays. They are comprised of three polypropylene layers: two outer layers of nonwoven polypropylene with a middle layer of a functional-technical film. UNI has a blue face with a black underside. UNI PLUS has a blue face with a white underside. UNI PLUS is fire retardant.

### BUILDING

- › For commercial and residential construction.
- › Designed for use with all cladding systems.
- › Performs on timber and steel framed buildings.
- › As a temporary cladding that allows interior works to continue with no cladding in place for up to 180 days when installed according to these instructions..
- › With buildings of all building heights, up to the permissible wind design pressure of 4.6 kPa.
- › With cladding and joinery that complies with the relevant provisions of the NZ Building Code for the site and location.
- › UNI and UNI PLUS are suitable as air barriers on walls that are not lined.
- › For vertical use only, not suitable as a roof underlay.
- › UNI Must be covered with a suitable wall lining to any occupied spacings.
- › UNI PLUS is fire retardant and may be used without restriction.

### LIMITATIONS

- › UNI and UNI PLUS (or any flexible air barrier) cannot provide seismic (bracing or racking), and fire-resistance.
- › For lightweight steel, a thermal break must be installed.
- › Where a building height is greater than 10 m and upper levels contain sleeping uses or other property the external wall must be subject to specific fire engineering.
- › In occupied spaces, UNI must always be installed in conjunction with an internal lining.
- › UNI and UNI PLUS double layer must be covered within 180 days from installation.



## Installation Guide

V1.0 May 2022

# Pre-installation

## HEALTH AND SAFETY

Take all necessary steps to ensure your safety and the safety of others:

- › ensure adequate ventilation or mechanical dust extraction when cutting or drilling
- › take care when fixing the wrap in windy conditions
- › wear appropriate safety equipment, clothing and footwear
- › use all tools in accordance with relevant instruction manuals
- › plan and monitor a safe approach for working at height; Select and use the right equipment
- › clear the work area of any obstruction before work starts.

For further information refer to:

- › WorkSafe. [July 2018] Small Construction Sites, the Absolutely Essential Health and Safety Toolkit.
- › WorkSafe. [December 2016] Health and Safety at Work, Quick Reference Guide.

These documents are available at [www.worksafe.govt.nz](http://www.worksafe.govt.nz).

## HANDLING AND STORAGE

### Handling

- › Care must be taken during loading, unloading, and transporting the materials to prevent pre-installation damage.
- › Unload the rolls carefully by hand. Do not crush the rolls and ensure they are protected from damage.

### Storage

- › Store the rolls on end under a cover, in a clean and dry area and out of direct sunlight.

## TOOLS AND EQUIPMENT REQUIRED

Install Masons UNI and UNI PLUS using standard carpentry tools and equipment. Use tools in accordance with good trade practice and supplier's instructions.





## Installation Guide

V1.0 May 2022

Product Description	Masons Code
UNI 2.74m x 18.25m = 50m <sup>2</sup>	UNI2.74x50
UNI PLUS 2.74m x 18.25m = 50m <sup>2</sup>	UNIPLUS2.74X50
UNI Fasteners Galv Nail and Washer 32mm QTY 2500 (for use with hammer)	UNIFASTGN
UNI Fasteners Stainless Steel Nail & Washer 32mm QTY 2500 (for use with hammer)	UNIFASTSS2500
UNI Fasteners. Bucket of collated screws for Stainless Steel frames. QTY 1500	UNIFASTSTLFRAME
UNI Cap Nailer Gun	UNICAPNAILER
UNI Nail Washer Pack for UNI Gun QTY 2000 Galv for use with Gun	UNINAILPACK
UNI Nail Washer Pack for UNI Gun. Stainless Steel 2,000 for use with Gun	UNINAILPACKSS

Product Description	Masons Code
40 Below Platinum Flashing Tape 150mm x 20m, 75mm x 20m	40PLBELOW150x20 40PLBELOW75x20
40 Below Flex Flashing Tape 150mm x 20m, 75mm x 20m	40BELOWFLX150x20 40BELOWFLX75x20
Penetration Seals - 1-75mm Pack of 10	PSEAL75
Penetration Seals - 80-170mm Pack of 10	PSEAL170
BrickTies - various sizes Galv or Stainless Steel	visit: mpb.co.nz
PEF Rod - various sizes 6-50mm diameter	visit: mpb.co.nz
Corner Guards - 50 pack	HYDROCG50
Dry Fix DPC - 200mm x 30m	DPC200

## Installation

### STEP 1: BUILDING CONSENT DOCUMENTATION

Where applicable, access and view building consent documentation.

### STEP 2: CHECK RELATED BUILDING WORK

For new and existing buildings ensure the primary structure is straight and true and within framing tolerances as described in Table 2.1, section 2 of NZS 3604:2011.

Check the framing centers are suitable for installation of UNI or UNI PLUS for the jobs wind zone, see table 1 - UNI or UNI PLUS fixings

Masons UNI or UNI PLUS can be used where cladding is installed over a cavity system or direct fixed cladding.

### STEP 3: INSTALL WRAP

#### DRAWING 1

#### Fit Wrap

Masons UNI or UNI PLUS must be installed with the printed side out, typically run horizontally on vertical framing. However, it is non directional and may be run in line with raking soffit lines or gables.



## Installation Guide

V1.0 May 2022

### DRAWING 1

#### Fixing - General

Masons supply Masons UNI® Fasteners for both timber and lightweight steel framing.

These are either hand fastened - blue cap or UNI fixing Gun fastened - green cap. Use cap nails or screws to secure UNI or UNI PLUS to the framing per the supplied fixing chart - see table 1.

Cavity Battens must be continuous and of treated timber or equivalent long life timber. First per the cladding manufacturers requirements or as per E2 AS1.

UNI and UNI PLUS may be fixed with combination of UNI cap nails and Timber cavity battens ensure maximum fixing centers are observed per Masons UNI and UNI PLUS fixing chart - Table 1.

Plan placement of battens and fit cap nails when tacking up or fixing off UNI or UNI PLUS so cap nails will not foul battens.

Where cavity battens are to be used ensure the 18-20 mm cavity is preserved. Pull UNI or UNI PLUS very tight over studs. For 600mm studs centers fitting of blue wrap strap (dan Band) should be installing cavity before installing battens.

For masonry veneer jobs with a larger cavity no wrap strap should be required as long as the UNI or UNI PLUS has been fitted taut and there is no billowing into the cavity.

### DRAWING 2

#### Fitting of an optional Soffit Strip

Measure and cut a soffit strip to run from the top of the top plate to below the first line of nogging.

Install the first layer of cut soffit strip, tack in place with UNI cap nails or Cap screws - avoid where fixing where battens will be placed. Then install the second soffit strip layer of UNI or UNI PLUS ensuring that vertical joints are staggered on different studs to the first layer. fix off leaving the bottom of the soffit strips free to make a horizontal overlap over the nogs - min 150 mm.

The horizontal over lap between layers must a minimum of 150 mm and made over framing.

#### Where a Soffit Strip has not been installed

Run UNI® or UNI PLUS along the top face, level with the top plate. Ensure that it is taut. Ensure the wrap extends a minimum of 50 mm below the bottom plate or bearer.

- Ensure UNI or UNI PLUS is level and pulled taut and is not allowed to billow into the cavity.
- Run the wrap over all openings and leave openings covered until windows and doors are ready to be installed



## Installation Guide

V1.0 May 2022

### DRAWING 3

#### Laps

Masons UNI or UNI PLUS must lap a minimum of 150 mm at horizontal joints and over framing. Vertical joints must always be over framing and a minimum of 150 mm lap. Vertical laps need to be staggered between the first layer of UNI or UNI PLUS so they fall on offset or different studs. see detail

### DRAWING 4

#### Installation of UNI or UNI PLUS double layer

In general - Upper wrap layers must lap over lower wrap sheets to ensure water is shed outside the wrap. All laps must be taped off with Masons 40 Below Flashing Tape (Flex or Platinum). Ensure adhesion by applying pressure using a plastic scraper. Install the first layer of UNI or UNI PLUS to framing, pull taut and tack sparingly with UNI cap nails, avoid fixing where cavity battens will place. UNI or UNI PLUS must run from the top of the top plate t 50 mm below the bottom plate.

Now install the second layer of UNI or UNI PLUS. Install taut. If a soffit strip has been installed slide lower UNI layers under the soffit strip and secure over lap with uni cap nails or cap screws.

Ensure the vertical laps fall on a different stud the first layer so the laps between layers one and two are offset.

Fix off at the correct centers for the wind zone see Table 1. Place UNI cap nails or screws top avoid fouling placement of timber cavity battens. Tape off all over laps with 40 below platinum or flex.

### DRAWING 11

#### Penetrations

Pipe penetrations must be sealed using Masons Penetration Seals or similar, ensuring good adhesion by applying pressure with a plastic scraper.

### DRAWING 10

#### Intersections - Apron Flashings, Interstorey Flashings, Change of pitch

Drape UNI or UNI PLUS over the upstand of apron, change of pitch or inter storey flashings. The UNI or UNI PLUS length should extend beyond the flashing by 100 - 150 mm at each end. Secure with UNI Cap Nail or Screw Fastenings. Tape all laps with 40 Below (Flex or Platinum) Flashing Tape.



## Installation Guide

V1.0 May 2022

### Tears

Regularly check Masons UNI or UNI PLUS for damage, tears, holes and gaps. Any damaged areas must be repaired immediately.

Repair by covering with new wrap lapping the damaged area by at least 150 mm and tape the wrap using Masons 40 Below Platinum or Flex. taking the UNI or UNI PLUS patch out to the the surrounding framing is also recommended. Fix wil cap nails and flash patch edges with 40 Below Platinum of Flex tape

Small tears can be repaired by taping with Masons UNI Seam and Repair Tape.

## STEP 5

### PREPARE OPENINGS

#### DRAWING 5

#### Openings

Remove the wrap by cutting the wrap diagonally from each corner of the opening. Fold the flaps of the cut membrane inside the opening. Staples may be used to fix the wrap to the inside of the window frame. Cut excess wrap flush with the internal face of the framing.

Flashing tape must be installed to all openings. Masons 40 Below (Flex or Platinum) Flashing Tape must be used.

All exposed wall framing in the openings must be protected by the Masons UNI or UNI PLUS, and Masons 40 Below Platinum or Flex Flashing Tape. To ensure the best possible adhesion make sure the substrate is clean, dry, free from dust or any other contaminants.

#### DRAWING 5

#### Window and Door sills

Place Masons Corner Guard over the Masons UNI or UNI PLUS and into the bottom corners of the window or door sill and staple to the jamb for timber framing or attach with double sided tape for steel framing.

Install Masons 40 Below (Flex or Platinum) Flashing Tape flush with the interior face of the opening along the entire length of the sill and up each jamb to a minimum of 200 mm. Press tape firmly into the corner over the guard first then slit at each corner and fold around onto the frame face. Fold remainder of the tape against the outer face of the frame and press firmly using the plastic scraper.



## Installation Guide

V1.0 May 2022

---

### Window and door heads

#### **DRAWINGS 5-6**

Install lintel pieces at top corners of opening, 200 mm along the lintel and 200 mm down the jamb. Slit Masons UNI or UNI PLUS at each corner and fold at least 50 mm onto outer face of building wrap. To create a seal at corner junctions, install butterflies at 45° across the corner of the head/jamb.

---

#### **STEP 6:**

#### **INSTALL JOINERY**

#### **DRAWINGS 5-9**

Install window and door joinery with head flashings and air seals.

Run Masons Dry Fix Plastic DPC up the side of the window jambs and up and under the head flashing. Fasten the DPC to the frame over the wrap using Masons UNI® Fasteners.

To seal above the head flashing, install an additional layer of UNI or UNI PLUS so that it drapes over the head flashing extending the length of the flashing by 100 – 150 mm at each end. Secure to framing with UNI® Fastenings. Tape all laps with 40 Below (Flex or Platinum) Flashing Tape.

The use of DRY fix DPC under the sill for a weather board or similar cladding is optional. It needs to be installed for masonry veneer as required by the building code.

---

#### **STEP 7:**

#### **QUALITY CHECK**

Ensure that all joins are taped, and all tears have been repaired. Ensure full adhesion around penetrations and openings.

Ensure Mason's UNI or UNI PLUS check list to ensure installation is per details and these instructions, helpful to complete this before inspections.

---



## Appendix 1

**TABLE 1: FIXING TABLE**

Stud centres (mm)	Fixings on studs (mm)	Minimum nogs centre (mm)	Perimeter fixing all around	Wind Zone	Fixing on Fixings nogs
600	Nail at 450 mm centres	800	Nail at 300 mm centres	Low/ Medium	Nail at centre 25 mm nails with plastic washer
450	Nail at 500 mm centres	800	Nail at 300 mm centres	Low/ Medium	Nail at centre 25 mm nails with plastic washer
400	Nail at 450 mm centres	800	Nail at 300 mm centres	Low/ Medium	Nail at centre 25 mm nails with plastic washer
600	Nail at 300 mm centres	800	Nail at 300 mm centres	High	Nail at centre 25 mm nails with plastic washer
450	Nail at 350 mm centres	800	Nail at 300 mm centres	High	Nail at centre 25 mm nails with plastic washer
400	Nail at 300 mm centres	800	Nail at 300 mm centres	High	Nail at centre 25 mm nails with plastic washer
400	Nail at 250 mm centres	800	Nail at 300 mm centres	Low/ Medium/ High/ Very High	Nail at centre 25 mm nails with plastic washer
300	Nail at 300 mm centres	800	Nail at 300 mm centres	Low/ Medium/ High/ Very High/ Extra High	Nail at centre 25 mm nails with plastic washer
300	Nail at 250 mm centres	800	Nail at 300 mm centres	Low/ Medium/ High/ Very High/ Extra High	Nail at centre 25 mm nails with plastic washer
300, 400, 450, 600	Battens with nails at 400 mm centres	800	Batten with nails at 300 mm centres	Low/ Medium/ High/ Very High/ Extra High	Battens with nails at 400 mm centres (2 nails min) Batten - 20 x 45 SG8 Nails - 60 2.8 ring shank galvanised





**UNI & UNI Plus Double Layer 180 days**

General Setout on Studs with UNI Fasteners  
 \* UNI fasteners & UNI cap nails are used interchangeably

Scale 1:20 Date

Drawing No.

**UNI.DL.01**

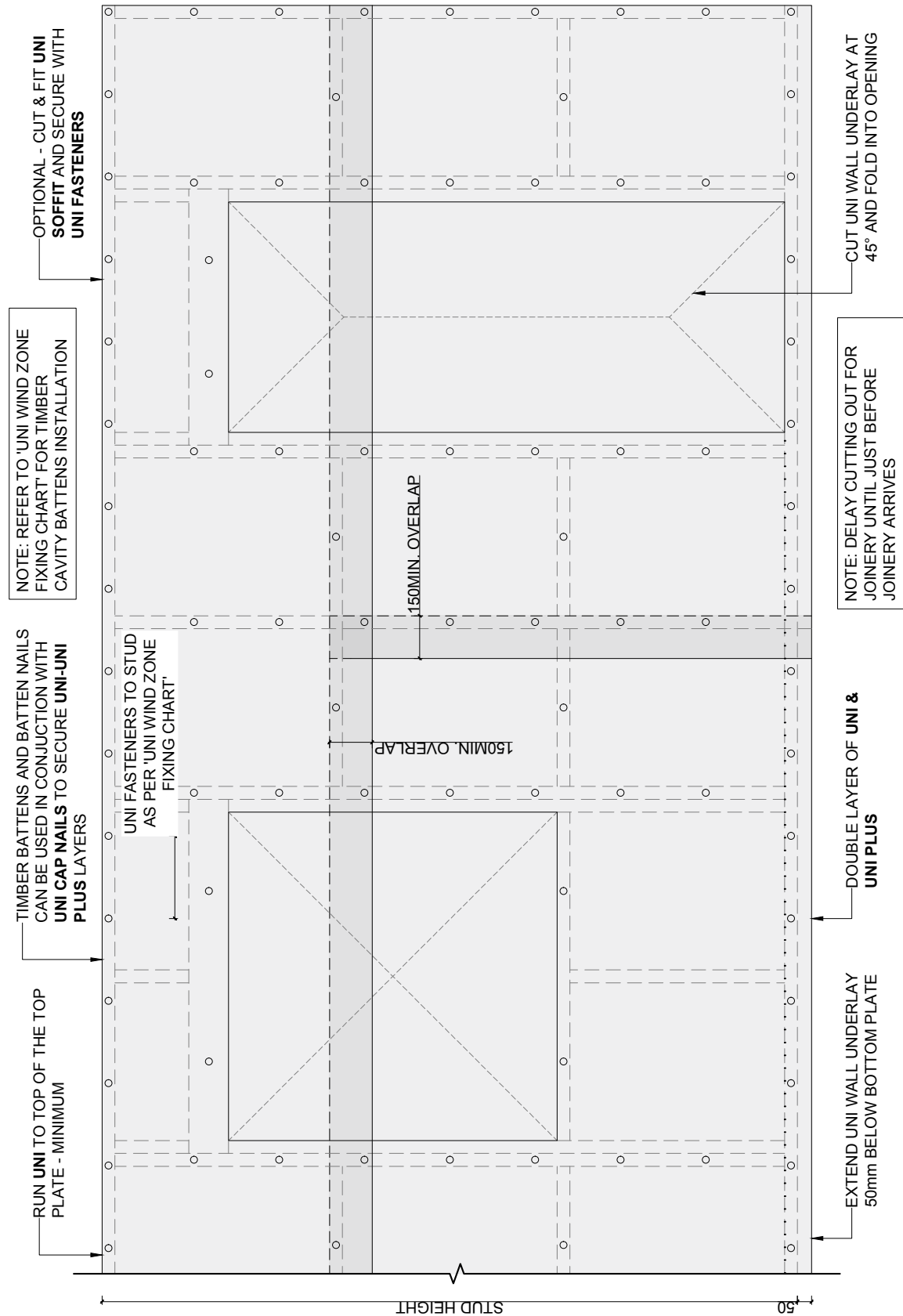



**UNI & UNI Plus Double Layer 180 days**

General Setout on Studs  
UNI Soffit Installation - Optional

Scale 1:20 Date

Drawing No. **UNI.DL.02**

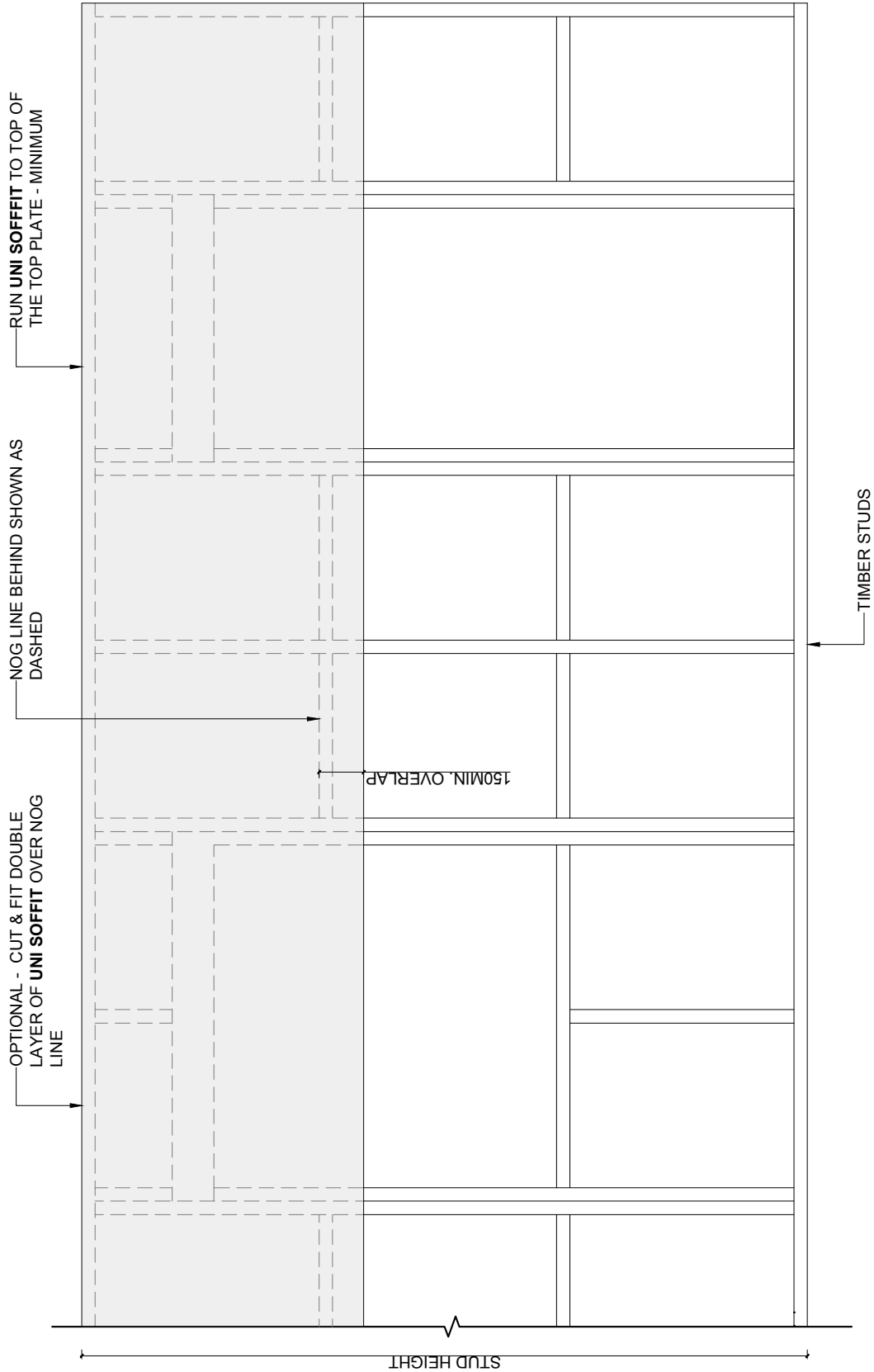



**MASONS**  
Designed Smart, Built Tough

**UNI & UNI Plus Double Layer 180 days**

General Setout on Studs  
First Layer of UNI/ UNI Plus Installation

Scale

1:20

Date

Drawing No.

**UNI.DL.03**

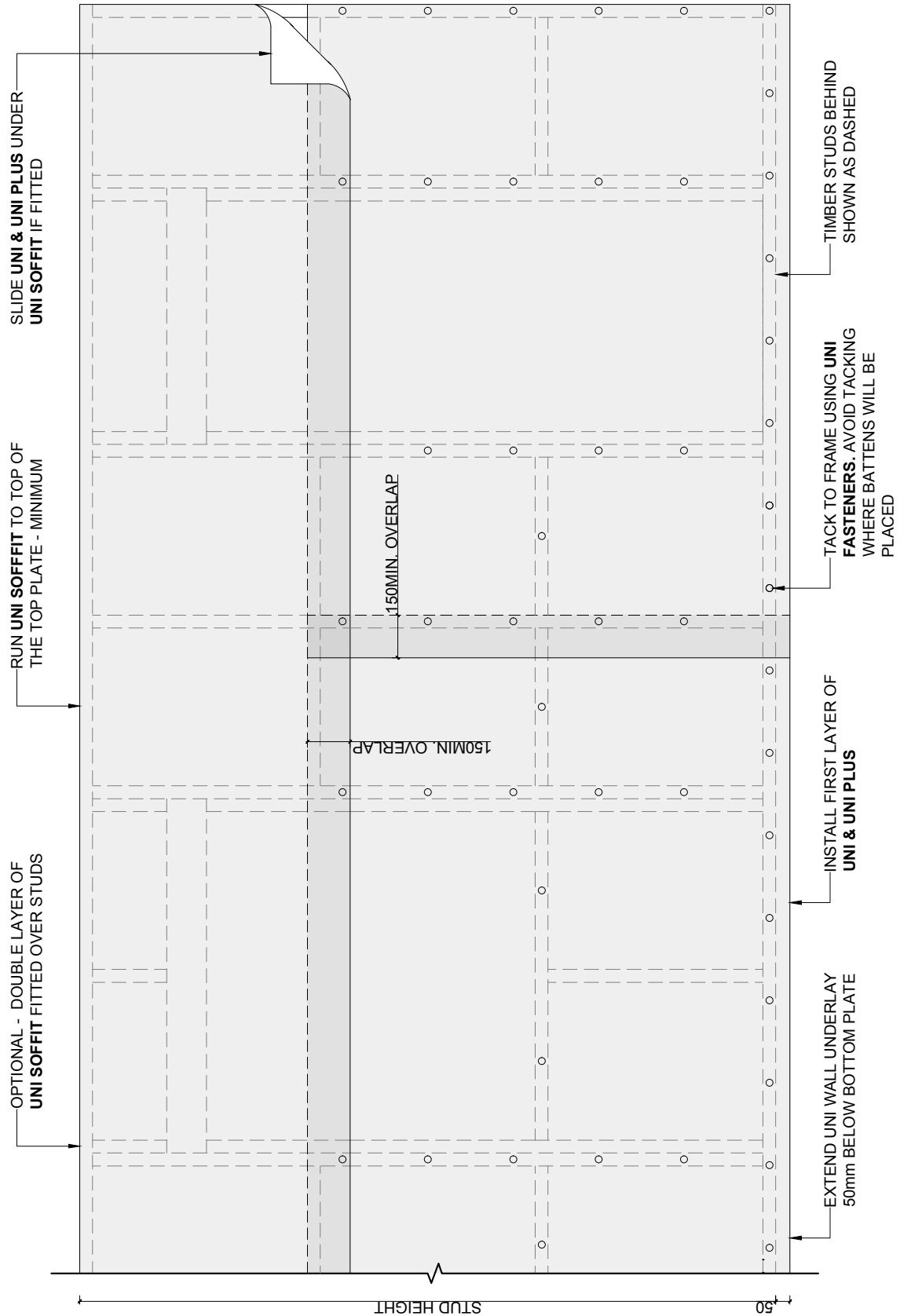



**UNI & UNI Plus Double Layer 180 days**  
 General Setout on Studs  
 Second Layer of UNI/ UNI Plus Installation

Scale 1:20 Date  
 Drawing No. **UNI.DL.04**

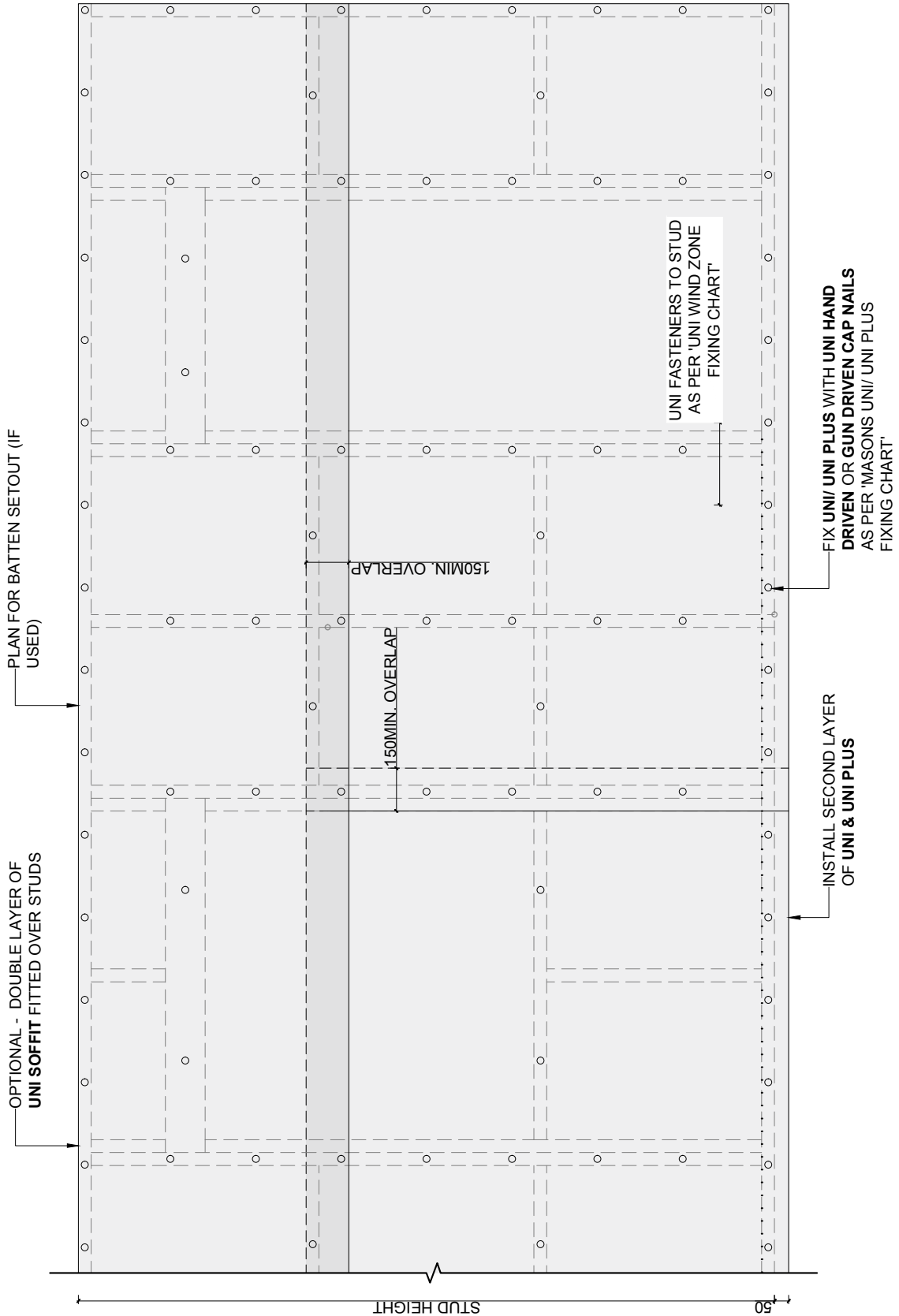



**UNI & UNI Plus Double Layer 180 days**

General Setout on Timber Frame - Additional Layer of UNI over Head Flashing

Scale 1:20 Date

Drawing No. **UNI.DL.05**

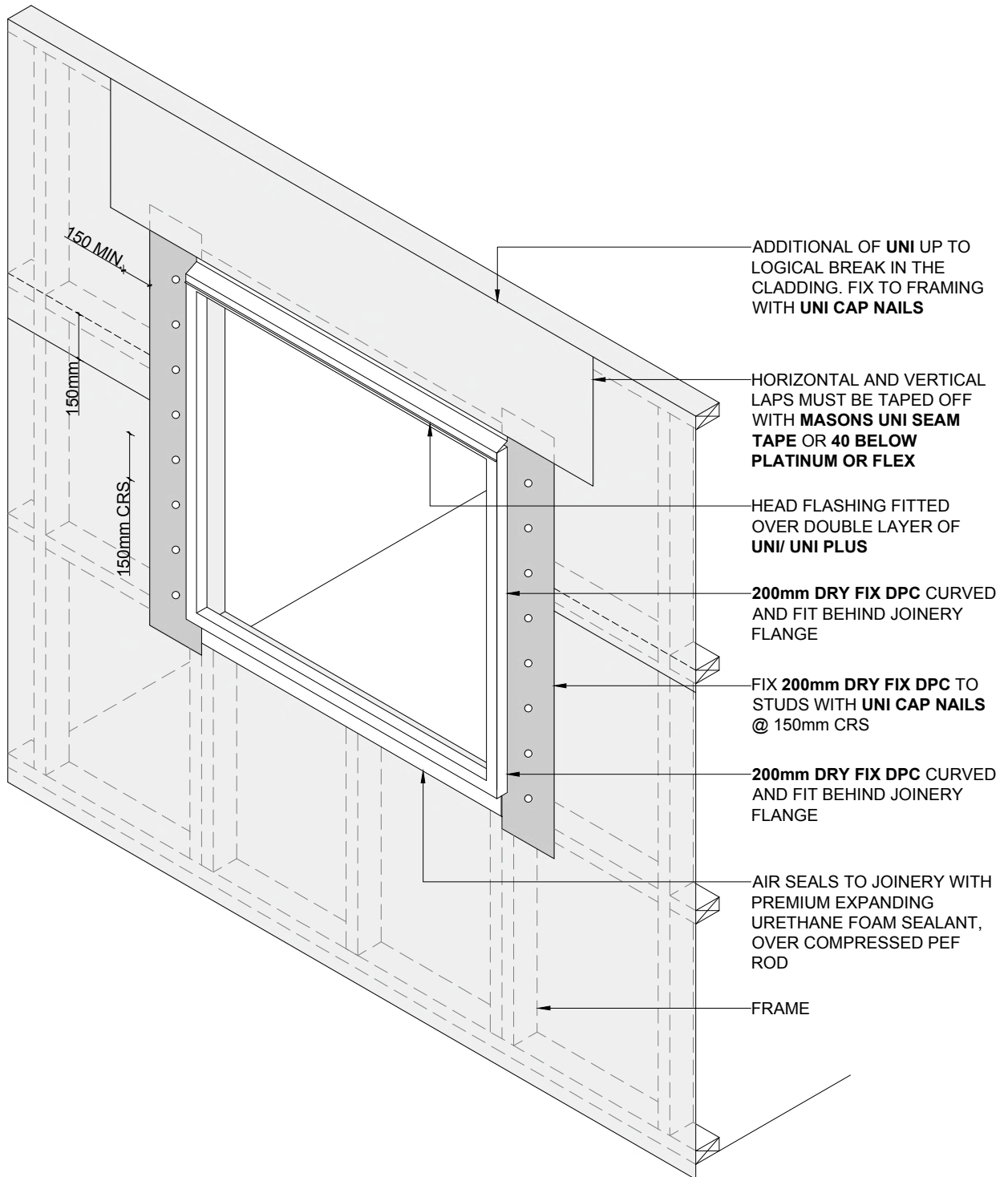



**UNI & UNI Plus Double Layer 180 days**

Window Installation

Scale 1:40 Date

Drawing No. **UNI.DL.06**

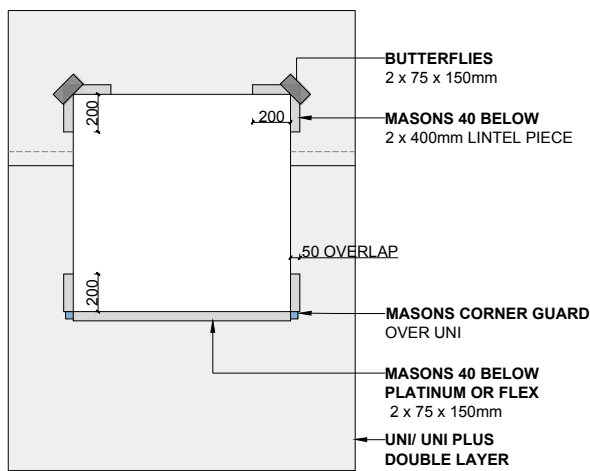

**STEP ONE**

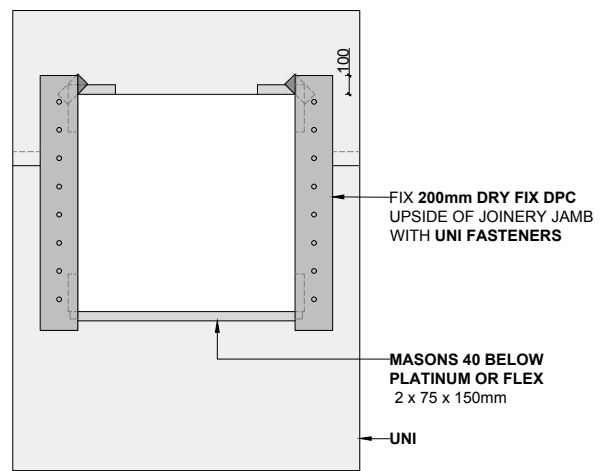

**STEP TWO**

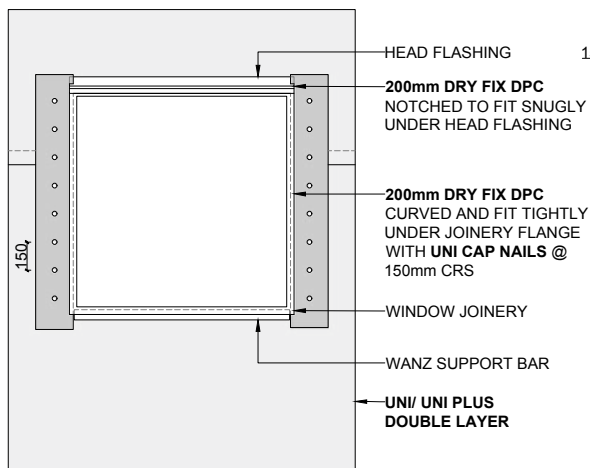

**STEP THREE**

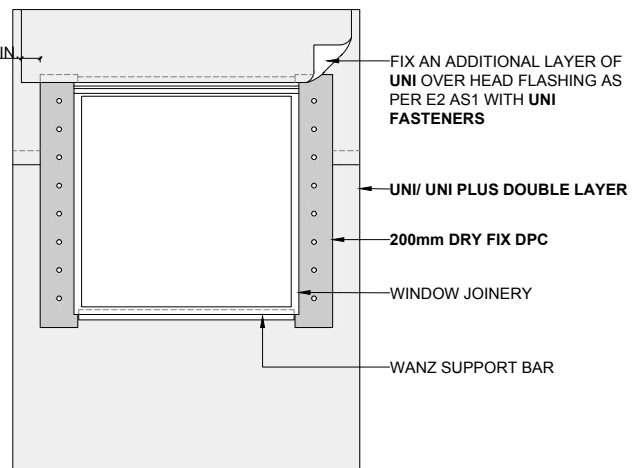

**STEP FOUR**



**MASONS**  
Designed Smart, Built Tough.

**UNI & UNI Plus Double Layer 180 days**  
Window Head Flashing to UNI & UNI Plus

Scale 1:2 Date

Drawing No. **UNI.DL.07**

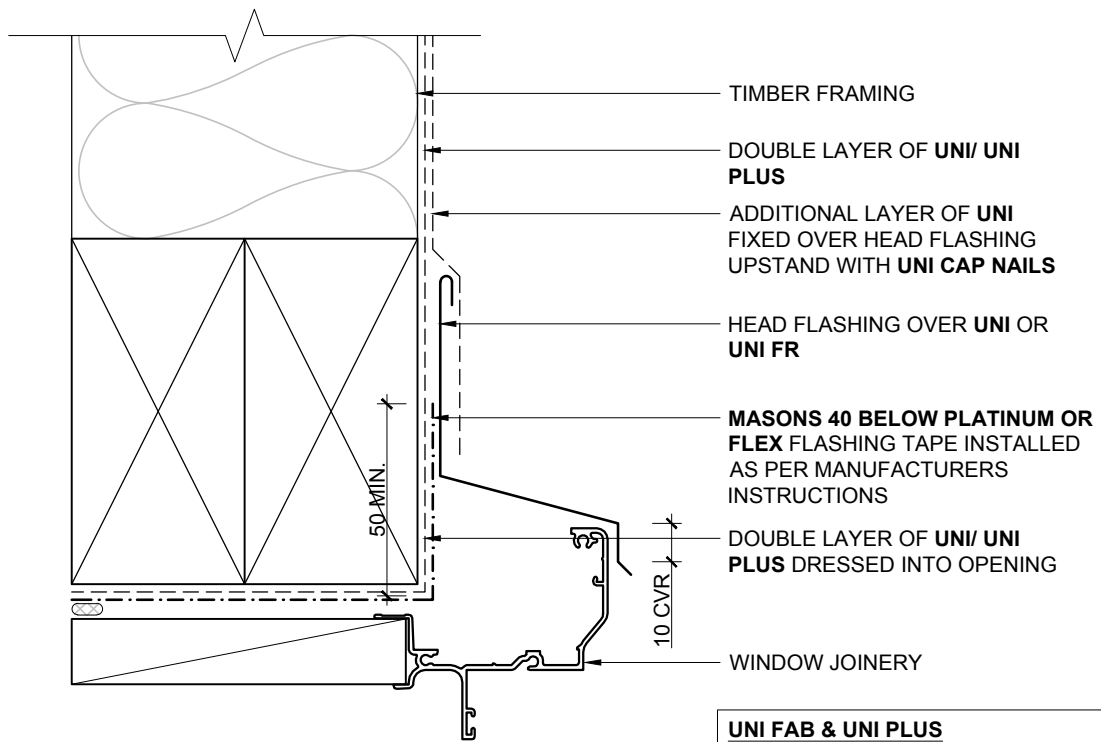

**ADDITIONAL UNI OVER HEAD FLASHING**

**UNI FAB & UNI PLUS**  
MANDATORY FOR VERY HIGH AND EXTRA HIGH WIND ZONE. RECOMMENDED FOR ALL WIND ZONES

**UNI PRO**  
MANDATORY FOR ALL WIND ZONES



**MASONS**  
Designed Smart, Built Tough.

**UNI & UNI Plus Double Layer 180 days**

Typical Jamb with 200mm Plastic DPC

Scale 1:2 Date

Drawing No. **UNI.DL.08**

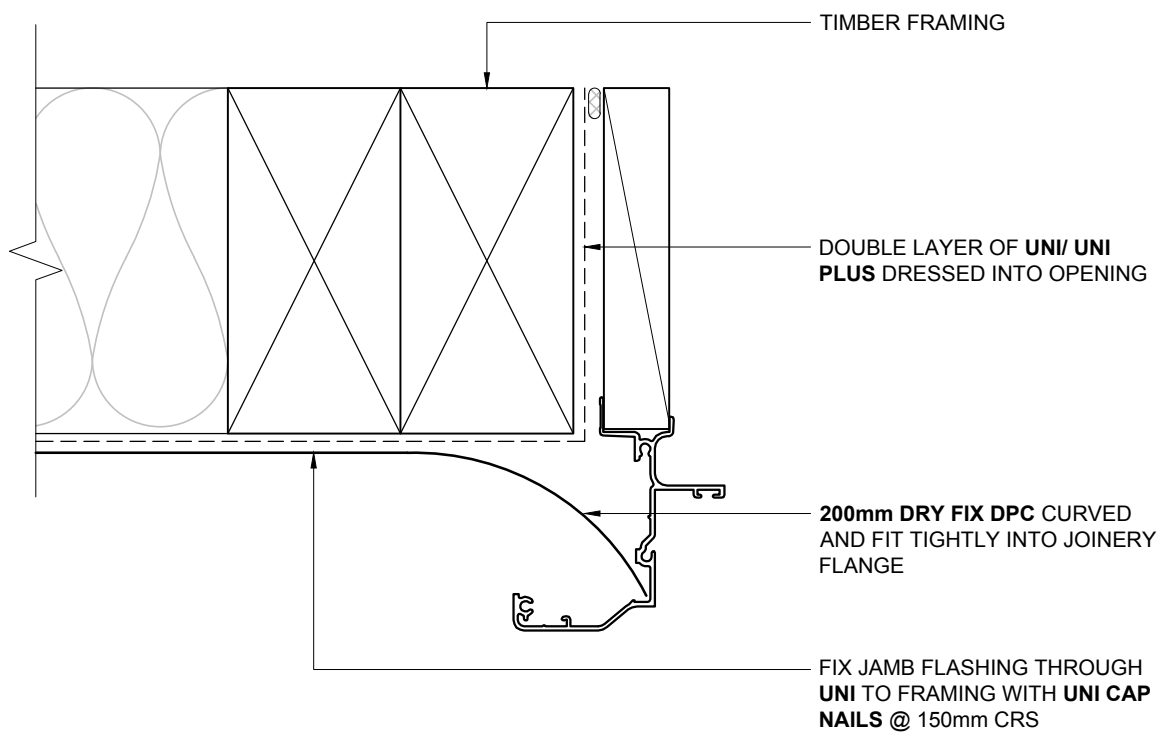





**MASONS**  
Designed Smart, Built Tough.

**UNI & UNI Plus Double Layer 180 days**

Brick Lintel Veneer Window Head

Scale 1:2 Date

Drawing No. **UNI.DL.09**

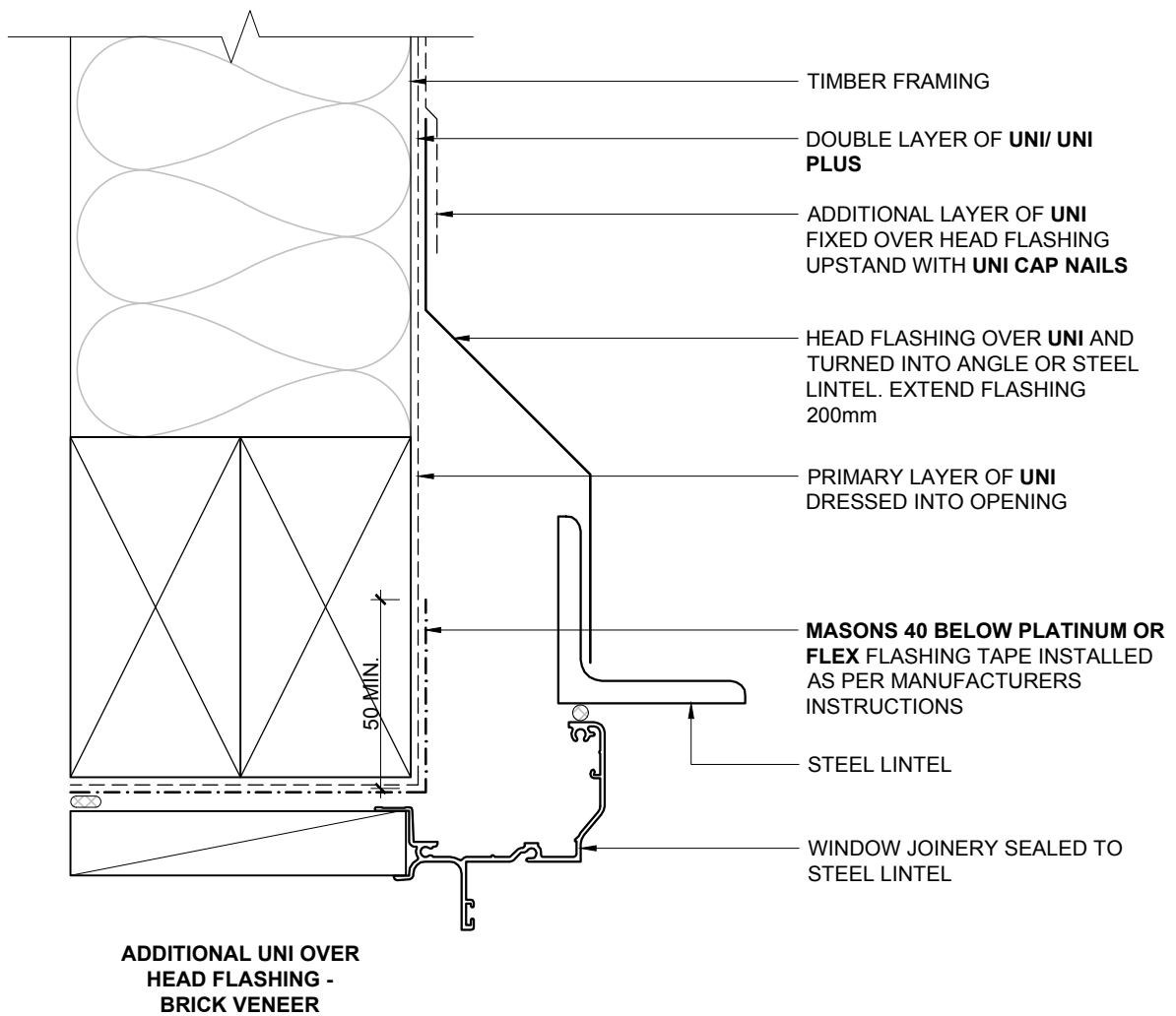



**MASONS**  
Designed Smart, Built Tough

**UNI & UNI Plus Double Layer 180 days**  
Apron Flashing Installation

Scale 1:2 Date

Drawing No. **UNI.DL.10**

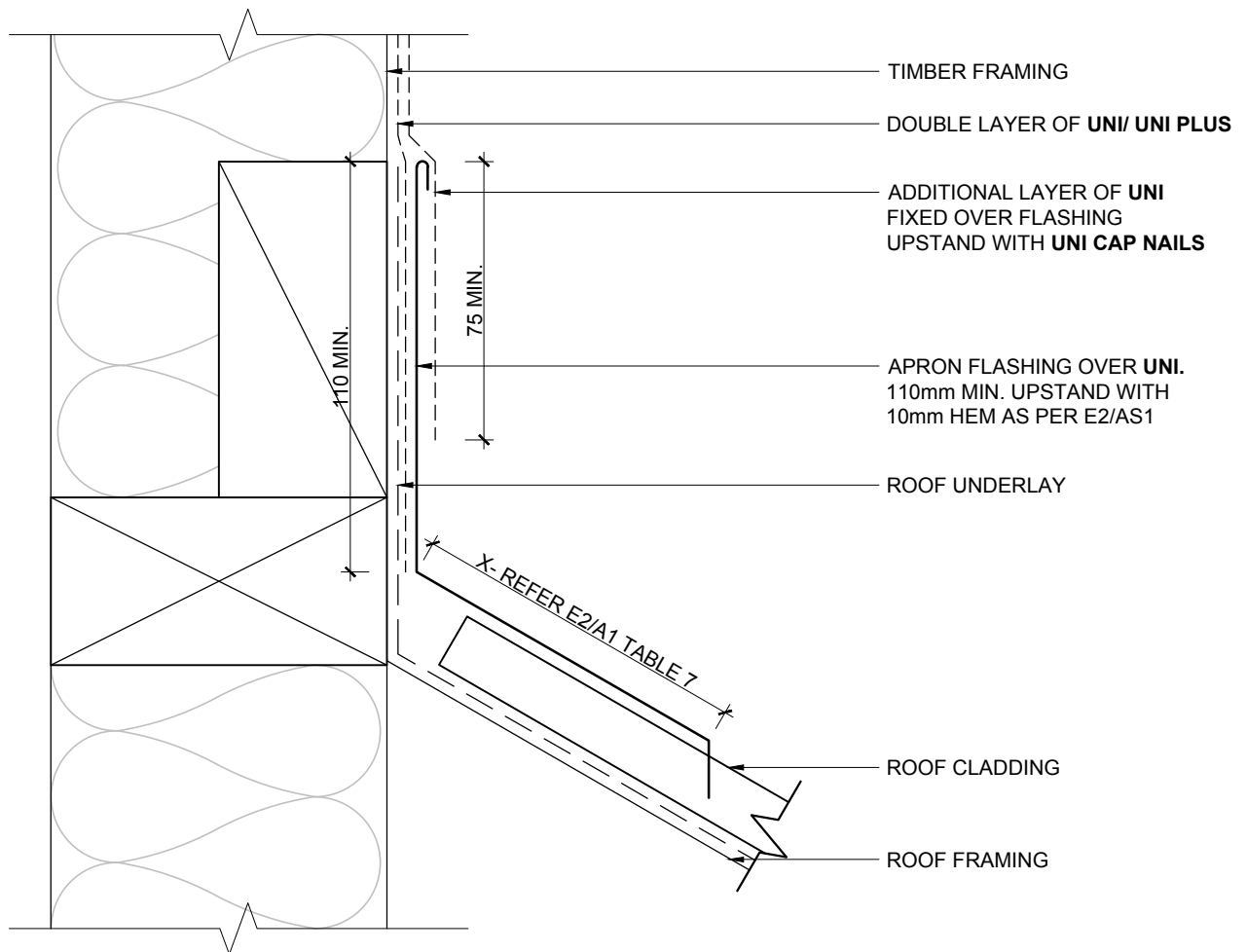



**MASONS**  
Designed Smart, Built Tough

**UNI & UNI Plus Double Layer 180 days**  
Penetration Seals

Scale 1:2 Date

Drawing No. **UNI.DL.11**

